From: Roger Rodriguez
Sent: Friday, March 17, 2017 1:03 PM PDT
To: William Hillyard; whillyard@cityofirvine.org
Subject: Achieving Facial Recognition Success - Webinar



New Webinar:

Achieving Facial Recognition Success with Lower Quality Images

Learn how this breakthrough technology can improve your match odds and help you close more cases!

Join retired NYPD Detective, Roger Rodriguez, as he showcases the new Enhancement Tools available within FaceSearch. These easy-to-use tools enable analysts and investigators to enhance select lower-quality images that previously could not meet the criteria for facial recognition searching.

They can include the following:

- Poor subject poses
- Low resolution or heavy pixelation
- Occlusion (any part of the face blocked or covered)
- Images found within a CCTV video

When: Wednesday, March 22nd 3:00 PM - 4:00 PM EST

Register Now →



2021 Las Positas Court, Suite #101
Livermore, CA. 94551

[Email Preferences](#) | [Unsubscribe](#)

From: Roger Rodriguez
Sent: Monday, March 20, 2017 1:08 PM PDT
To: William Hillyard; whillyard@cityofirvine.org
Subject: [Webinar] Achieving Facial Recognition Success



New Webinar:

Achieving Facial Recognition Success with Lower Quality Images

Learn how this breakthrough technology can improve your match odds and help you close more cases!

Join retired NYPD Detective, Roger Rodriguez, as he showcases the new Enhancement Tools available within FaceSearch. These easy-to-use tools enable analysts and investigators to enhance select lower-quality images that previously could not meet the criteria for facial recognition searching.

They can include the following:

- Poor subject poses
- Low resolution or heavy pixelation
- Occlusion (any part of the face blocked or covered)
- Images found within a CCTV video

When: Wednesday, March 22nd 3:00 PM - 4:00 PM EST

Register Now →



2021 Las Positas Court, Suite #101
Livermore, CA. 94551

[Email Preferences](#) | [Unsubscribe](#)

From: Roger Rodriguez
Sent: Tuesday, March 21, 2017 1:21 PM PDT
To: William Hillyard; whillyard@cityofirvine.org
Subject: Facial Recognition Success with Low Quality Images



Just a Few Seats Left:

Achieving Facial Recognition Success Webinar

Many investigations using facial recognition encounter one common problem - poor quality images.

[In this free webinar](#), Roger will showcase FaceSearch's easy-to-use tools that enable analysts and investigators to enhance lower-quality images that previously could not meet the criteria for facial recognition searching.

Roger Rodriguez, spearheaded the NYPD's first dedicated facial recognition unit. The unit has conducted over 8,500 investigations, many with poor quality images.

You will learn how to correct low quality images such as:

- Poor subject poses
- Low resolution or heavy pixelation
- Occlusion (any part of the face blocked or covered)
- Images found within a CCTV video

When: TOMORROW, March 22nd 3:00 PM - 4:00 PM EST

Register Now →



2021 Las Positas Court, Suite #101

Livermore, CA. 94551

[Email Preferences](#) | [Unsubscribe](#)

From: Vigilant Solutions
Sent: Friday, May 5, 2017 1:52 PM PDT
To: William Hillyard; whillyard@cityofirvine.org
Subject: Two New Webinars



REGISTER NOW FOR UPCOMING WEBINARS:

Sex Offender Management & Investigations, May 10

Facial Recognition & Cyber Crimes, May 17



SEX OFFENDER MANAGEMENT AND INVESTIGATIONS

Wednesday, May 10th 3:00 PM EST

Join Sgt. Kyle Hoertsch with the Sacramento County Sheriff's Department as he discusses best practices for sex offender management and investigations.

REGISTER NOW

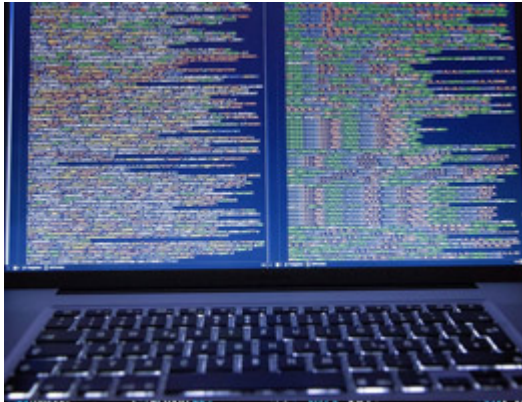

FACIAL RECOGNITION AND CYBER CRIMES

Wednesday, May 17th 3:00 PM EST

Retired NYPD Detective, Roger Rodriguez will share how he analyzed images for cyber-crime investigations such as prostitution rings, identity theft, fraud, and child exploitation using poor quality images obtained from victims, social media, and other sources.

[REGISTER NOW](#)



2021 Las Positas Ct, Suite #101 Livermore, CA 94551

[Email Preferences](#) | [Unsubscribe](#) | [Vigilant Solutions](#)

© 2017 Vigilant Solutions, All Rights Reserved.

From: Vigilant Solutions
Sent: Wednesday, May 17, 2017 11:43 AM PDT
To: William Hillyard; whillyard@cityofirvine.org
Subject: Webinar: Facial Recognition and Cyber Crimes



Webinar: Facial Recognition and Cyber Crimes

According to the FBI, the threat from cyber crimes is serious – and growing. And it's not just corporations that are at risk from this threat. Citizens in your communities could be targets of fraudsters and identity thieves, or children could be targeted by online predators.

[In this webinar](#), Retired NYPD Detective, Roger Rodriguez will share how to analyze images for cyber-crime investigations such as prostitution rings, identity theft, fraud, and child exploitation. In many cases, these investigations included poor quality images obtained from crime victims, social media, or other online sources.

Topics Include:

- Cyber crime overview
- Using facial recognition in cyber crime investigations
- Image editing techniques for CCTV or social media images
- Use case examples

When: Friday, May 19th 3:00 PM EST / 2:00 PM CST

[Register Now→](#)

Space is limited, please Register early to save your spot.



2021 Las Positas Court, Suite #101
Livermore, CA. 94551
[Unsubscribe](#)

From: Greg Mills
Sent: Tuesday, June 13, 2017 12:48 PM PDT
To: William Hillyard
Subject: Anaheim PD Lunch and Learn



Anaheim PD Lunch and Learn

Join the Anaheim Police Department for a Lunch and Learn featuring Vigilant Solutions on Wednesday, June 21st from 10:00 AM - 1:00 PM at the Anaheim Police Department - East Sub Station.

It will be an informative meeting for all involved to understand how license plate recognition (LPR) and facial recognition tools can be used to enhance investigations and close more cases.

Topics will include:

- LPR Data and Analytic Tools to Develop Investigative Leads
- Privacy, Policy and Legislation
- Data Sharing and Interoperability
- Applications for Facial Recognition in the Investigative Process

When: Wednesday, June 21st, 10:00 AM to 1:00 PM

Where: [Anaheim Police Department - East Sub Station 8201 E Santa Ana Canyon Rd, Anaheim, CA 92808](#)

Lunch will be provided for all RSVPs.

RSVP Now→



2021 Las Positas Court, Suite #101

Livermore, CA. 94551

[Unsubscribe](#)

From: Greg Mills
Sent: Monday, June 19, 2017 1:03 PM PDT
To: William Hillyard
Subject: Anaheim PD Lunch and Learn



RSVP Now for the Anaheim PD Lunch and Learn

This is your last chance to register for the Anaheim PD Lunch and Learn featuring Vigilant Solutions on Wednesday, June 21st from 10:00 AM - 1:00 PM at the Anaheim Police Department - East Sub Station.

It will be an informative meeting for all involved to understand how license plate recognition (LPR) and facial recognition tools can be used to enhance investigations and close more cases.

Topics will include:

- LPR Data and Analytic Tools to Develop Investigative Leads
- Privacy, Policy and Legislation
- Data Sharing and Interoperability
- Applications for Facial Recognition in the Investigative Process

When: Wednesday, June 21st, 10:00 AM to 1:00 PM

Where: [Anaheim Police Department - East Sub Station 8201 E Santa Ana Canyon Rd, Anaheim, CA 92808](#)

Lunch will be provided for all RSVPs.

RSVP Now→



2021 Las Positas Court, Suite #101

Livermore, CA. 94551

[Unsubscribe](#)

From: Mark at Vigilant
Sent: Thursday, June 22, 2017 11:36 AM PDT
To: William Hillyard; whillyard@ci.irvine.ca.us
Subject: Upcoming Training Webinars



Advanced LEARN Training Webinar

Monday, July 3rd 1:00 PM - 3:00 PM EDT

This training session is for LEARN users who are familiar with the basic features and want to build their knowledge of LEARN to increase case lead generation. Topics will include creating Geo Zones-when and why to use them, Advance License Plate Query, review of the new GUI in Locate Analysis and advanced Stakeout techniques.

[Register Now](#)

Other Upcoming Training Webinars:



Basic LEARN Training:

June 23rd 1:00 PM EDT

A basic introduction to License Plate Recognition (LPR), this class will cover how LEARN's tools merge data with powerful analytic tools to create useful visual intelligence.

[Register Now](#)



FaceSearch Training:

July 5th 3:00 PM EDT

Introductory level training session for all FaceSearch users that will show you how to develop more leads with facial recognition.

[Register Now](#)



LEARN Mobile Companion Training: July 5th 1:00 PM EDT

In-depth training for the LEARN Mobile Companion app for iOS and Android devices. Learn how to scan plates, add hot plates, and get alerts from your mobile device.

[Register Now](#)

LEARN Agency Manager Training: July 7th 1:00 PM EDT

This training session is for LEARN Agency Managers and will cover the administrative functions of the LEARN platform.

[Register Now](#)

[Follow on Twitter](#) [Follow on Facebook](#)

Copyright © 2017, All rights reserved.

Our mailing address is:

Vigilant Solutions
2021 Las Positas Court
Suite 101
Livermore, CA 94551

[unsubscribe from all emails](#) [update subscription preferences](#)

From: Vigilant Solutions
Sent: Friday, June 23, 2017 12:06 PM PDT
To: William Hillyard
Subject: Webinar: Validate or Exonerate



[Webinar]

Validate or Exonerate:

The Importance of Facial Recognition Checks and Balances

Having the right checks and balances in place can help law enforcement facial recognition programs flourish. Join Roger Rodriguez, as he shows you how a fully integrated CJIS compliant system, with good enhancement tools and built-in auditing and reporting can assist agencies to validate or exonerate persons wanted in criminal investigations.

Topics Include:

- The importance of reporting and annotation tools
- Checks and balances
- Privacy and compliance
- Use case examples

When: Thursday, July 13th 3:00 PM EST / 2:00 PM CST

[Register Now→](#)

Space is limited, please register early to save your spot.



2021 Las Positas Court, Suite #101
Livermore, CA. 94551

[Unsubscribe](#)

From: Vigilant Solutions
Sent: Thursday, July 6, 2017 12:42 PM PDT
To: William Hillyard
Subject: [Webinar] Validate or Exonerate: The Importance of Facial Recognition Checks and Balances



Register Now For Our Next Facial Recognition Webinar

There are still a few open spots for our upcoming webinar, Validate or Exonerate: The Importance of Facial Recognition Checks and Balances.

Join Retired NYPD Detective, Roger Rodriguez, as he shows you how a fully integrated CJIS compliant system, with good enhancement tools and built-in auditing and reporting can assist agencies to validate or exonerate persons wanted in criminal investigations.

Topics Include:

- The importance of reporting and annotation tools
- Checks and balances
- Privacy and compliance
- Use case examples

When: Thursday, July 13th 3:00 PM EST / 2:00 PM CST

[Register Now→](#)

Space is limited, please register early to save your spot.



2021 Las Positas Court, Suite #101
Livermore, CA. 94551
[Unsubscribe](#)

From: Vigilant Solutions
Sent: Tuesday, July 11, 2017 1:30 PM PDT
To: William Hillyard
Subject: Ready to become a better investigator?



Ready to be a better investigator?

Join our Facial Recognition Webinar

There are still a few open spots for our upcoming webinar, Validate or Exonerate: The Importance of Facial Recognition Checks and Balances.

In this webinar, Retired NYPD Detective, Roger Rodriguez, will show you how a fully integrated CJIS compliant system, with good enhancement tools and built-in auditing and reporting can assist agencies to validate or exonerate persons wanted in criminal investigations.

Topics Include:

- The importance of reporting and annotation tools
- Checks and balances
- Privacy and compliance
- Use case examples

When: Thursday, July 13th 3:00 PM EST / 2:00 PM CST

[Register Now→](#)

Space is limited, please register early to save your spot.

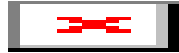

2021 Las Positas Court, Suite #101
Livermore, CA. 94551

[Unsubscribe](#)

From: Tom Joyce
Sent: Thursday, July 20, 2017 1:26 PM PDT
To: William Hillyard
Subject: [Webinar] Next Thursday



WEBINAR: DISRUPTING ORGANIZED CRIME WITH LPR AND FACIAL RECOGNITION

Thursday, July 27th 3:00 PM EST

[REGISTER NOW](#)

Retired FBI Agent Kevin Sheridan, discusses how vehicle location data and facial recognition help disrupt organized crime.

Product in and money out! Law enforcement agencies are often challenged by the degradation of communities they serve brought on by organized crime groups. These groups use vehicles to traffic guns, humans, narcotics and currency and the unidentified faces of victims and offenders are often caught in various types of imagery. These vehicles and faces are leads that need to be resolved.

Join retired FBI Agent Kevin Sheridan, Director of Business Development for Vigilant Solutions, as he discusses how vehicle location data and facial recognition technology can help disrupt these organized crime groups and have an effect on the local crime rates in the communities they operate.

[REGISTER FOR THE WEBINAR NOW](#)



2021 Las Positas Ct, Suite #101 Livermore, CA 94551

[Email Preferences](#) | [Unsubscribe](#) | [Vigilant Solutions](#)

© 2017 Vigilant Solutions, All Rights Reserved.

From: Heather Richardson
Sent: Tuesday, August 1, 2017 2:21 PM PDT
To: William Hillyard
Subject: Webinar Thursday



WEBINAR THURSDAY:

Disrupting Organized Crime with LPR & Facial Recognition

Thursday, August 3rd 3:00 PM EDT

SAVE YOUR SPOT

We have a few open spots left before Thursday's webinar is full. [Register now](#) to reserve your spot.

Product in and money out! Law enforcement agencies are often challenged by the degradation of communities they serve brought on by organized crime groups. These groups use vehicles to traffic guns, humans, narcotics and currency and the unidentified faces of victims and offenders are often caught in various types of imagery. These vehicles and faces are leads that need to be resolved.

Join retired NYPD Detective Tom Joyce, Vice President of Business Development for Vigilant Solutions, as he discusses how vehicle location data and facial recognition technology can help disrupt these organized crime groups and have an effect on the local crime rates in the communities they operate.

REGISTER FOR THE WEBINAR NOW

Looking forward to you joining us!

Heather Richardson
Partner Marketing Manager

www.vigilantsolutions.com

P.S. If you can't make it to the webinar download the [LPR Beyond the Lens eBook](#) to learn how high tech crime fighters use vehicle location data.



1152 Stealth Street, Livermore, CA 94551

[Email Preferences](#) | [Unsubscribe](#) | [Vigilant Solutions](#)

© 2017 Vigilant Solutions, All Rights Reserved.

From: Heather Richardson
Sent: Tuesday, August 22, 2017 1:44 PM PDT
To: William Hillyard
Subject: Webinar: Facial Recogniton in Investigations Involving Children



WEBINAR: USING FACIAL RECOGNITION IN INVESTIGATIONS THAT INVOLVE CHILDREN

Thursday, August 31st, 3:00 PM - 4:00 PM EST

[REGISTER NOW](#)

Roger Rodriguez, Retired NYPD Detective, shares best practices, techniques and strategies.

Agencies like the NYPD have analyzed images for investigations including crimes against children that span trafficking, abuse, child prostitution and exploitation. Attend this webinar and go step-by-step through the facial recognition investigative process, learn essential best practices, techniques and strategies to produce facial recognition leads. Get the facts on how to deal with less than perfect images from sources including CCTV cameras, bank ATM's, social media, and sources where faces are often rejected for facial recognition.

Join Vigilant Solutions law enforcement facial recognition expert, Roger Rodriguez, as he discusses how a unique approach can make use of these images to generate quality leads in any investigation.

[REGISTER NOW TO SAVE YOUR SPOT](#)





2021 Las Positas Ct, Suite #101 Livermore, CA 94551

[Email Preferences](#) | [Unsubscribe](#) | [Vigilant Solutions](#)

© 2017 Vigilant Solutions, All Rights Reserved.

From: Heather Ford
Sent: Thursday, August 24, 2017 12:40 PM PDT
To: William Hillyard
Subject: [Webinar] Retired NYPD Detective shares best practices, techniques and strategies



WEBINAR: USING FACIAL RECOGNITION IN INVESTIGATIONS THAT INVOLVE CHILDREN

Thursday, August 31st, 3:00 PM - 4:00 PM EST

[REGISTER NOW](#)

Roger Rodriguez, Retired NYPD Detective, shares best practices, techniques and strategies.

Agencies like the NYPD have analyzed images for investigations including crimes against children that span trafficking, abuse, child prostitution and exploitation. Attend this webinar and go step-by-step through the facial recognition investigative process, learn essential best practices, techniques and strategies to produce facial recognition leads. Get the facts on how to deal with less than perfect images from sources including CCTV cameras, bank ATM's, social media, and sources where faces are often rejected for facial recognition.

Join Vigilant Solutions law enforcement facial recognition expert, Roger Rodriguez, as he discusses how a unique approach can make use of these images to generate quality leads in any investigation.

[REGISTER NOW TO SAVE YOUR SPOT](#)





2021 Las Positas Ct, Suite #101 Livermore, CA 94551

[Email Preferences](#) | [Unsubscribe](#) | [Vigilant Solutions](#)

© 2017 Vigilant Solutions, All Rights Reserved.

From: Heather Richardson
Sent: Wednesday, August 30, 2017 6:20 AM PDT
To: William Hillyard
Subject: [Webinar] Retired NYPD Detective shares best practices, techniques and strategies



USING FACIAL RECOGNITION IN INVESTIGATIONS THAT INVOLVE CHILDREN

Thursday, August 31st, 3:00 PM - 4:00 PM EST

[REGISTER FOR THE WEBINAR NOW](#)

Roger Rodriguez, Retired NYPD Detective, shares best practices, techniques and strategies.

Join Vigilant Solutions law enforcement facial recognition expert, Roger Rodriguez, as he discusses how a unique approach can make use of these images to generate quality leads in any investigation.

Topics will include:

- Step-by-step facial recognition investigative process
- Essential best practices
- Techniques and strategies for producing facial recognition leads

[REGISTER FOR THE WEBINAR NOW](#)



2021 Las Positas Ct, Suite #101 Livermore, CA 94551

[Email Preferences](#) | [Unsubscribe](#) | [Vigilant Solutions](#)

© 2017 Vigilant Solutions, All Rights Reserved.

From: Mark at Vigilant
Sent: Thursday, September 21, 2017 10:06 AM PDT
To: William Hillyard; whillyard@ci.irvine.ca.us
Subject: Upcoming Training Webinars



Basic LEARN Training Webinar

Monday, September 25th 1:00 PM - 3:00 PM EST

Data such as Fixed LPR, Mobile LPR, as well as Vigilant's own network of commercial LPR data are merged together with powerful analytics and condensed into meaningful and visual intelligence. (2 hours long)

[Register Now](#)

Other Upcoming Training Webinars:



**Advanced LEARN Training:
October 10th 1:00 PM EST**

Build their knowledge of LEARN to increase case lead generation. Topics will include Creating Geo Zones-when and why to use them, Advance License Plate Query, Review of the new GUI in Locate Analysis and Advanced Stakeout techniques. (2 hours long)

[Register Now](#)



**FaceSearch Training:
October 12th 1:00 PM EST**

Introductory level training session for all FaceSearch users that will show you how to develop more leads with facial recognition using Vigilant's mugshot gallery of 16+ million images. (2 hours long)

[Register Now](#)



LEARN Mobile Companion Training: Nov. 2nd 1:00 PM EST

In-depth training for the LEARN Mobile Companion app for iOS and Android devices. Learn how to scan plates, add hot plates, and get alerts from your mobile

device.

[Register Now](#)



**LEARN Agency Manager Training: October 13th
1:00 PM EST**

This training session is for LEARN Agency Managers and will cover the administrative functions of the LEARN platform.

[Register Now](#)

[Follow on Twitter](#) [Follow on Facebook](#)

Copyright © 2017 , All rights reserved.

Our mailing address is:

Vigilant Solutions
1152 Stealth Street
Livermore, CA 94551

[unsubscribe from all emails](#) [update subscription preferences](#)

From: Mark at Vigilant
Sent: Friday, October 27, 2017 8:09 AM PDT
To: William Hillyard; whillyard@ci.irvine.ca.us
Subject: Upcoming Training Webinars



Basic LEARN Training Webinar

Monday, October 30th 1:00 PM - 3:00 PM EST

Data such as Fixed LPR, Mobile LPR, as well as Vigilant's own network of commercial LPR data are merged together with powerful analytics and condensed into meaningful and visual intelligence. (2 hours long)

[Register Now](#)

Other Upcoming Training Webinars:



**Advanced LEARN Training:
October 31st 1:00 PM EST**

Build their knowledge of LEARN to increase case lead generation. Topics will include Creating Geo Zones-when and why to use them, Advance License Plate Query, Review of the new GUI in Locate Analysis and Advanced Stakeout techniques. (2 hours long)

[Register Now](#)



**FaceSearch Training:
November 3rd 1:00 PM EST**

Introductory level training session for all FaceSearch users that will show you how to develop more leads with facial recognition using Vigilant's mugshot gallery of 16+ million images. (2 hours long)

[Register Now](#)



LEARN Mobile Companion Training: Nov. 2nd 1:00 PM EST

In-depth training for the LEARN Mobile Companion app for iOS and Android devices. Learn how to scan plates, add hot plates, and get alerts from your mobile

device.

[Register Now](#)



**LEARN Agency Manager Training:
November 21st 1:00 PM EST**

This training session is for LEARN Agency Managers and will cover the administrative functions of the LEARN platform.

[Register Now](#)

[Follow on Twitter](#) [Follow on Facebook](#)

Copyright © 2017 , All rights reserved.

Our mailing address is:

Vigilant Solutions
1152 Stealth Street
Livermore, CA 94551

[unsubscribe from all emails](#) [update subscription preferences](#)

From: CellHawk
Sent: Tuesday, January 30, 2018 7:01 AM PST
To: whillyard@cityofirvine.org
Subject: CellHawk Quarterly Newsletter

[View this email in your browser](#)

QUARTERLY NEWSLETTER



- JANUARY 2018 -

Looking back at 2017, we here at Hawk Analytics would like to say "thank you" for an amazing year. We built relationships with wonderful people and assisted in solving hundreds of cases that allowed for children to be found and families to receive closure.

Our Hawk team will continue to ensure the highest quality product and customer success. From training new users to assisting on active cases, we guarantee the best service will be provided whether you are a current customer or not. Our company values are built on passion and purpose because we believe in doing what is right in order to make a difference.

We value each and every one of you and thank you for your continued support of **CellHawk**. We look forward to building even more relationships this upcoming year and adding new organizations to the long list of those we so proudly serve!

Sincerely,

A handwritten signature in blue ink, appearing to read "Mike Melson".

Mike Melson
Hawk Analytics, Inc. | CellHawk
Founder | President

- CELLHAWK UPDATE -

Recently, **CellHawk** installed new features that when used to their full potential can identify new leads that were unable to be seen before!

One of these new features is to filter by accuracy range size with NELOS records.

When you obtain NELOS records from AT&T, some of the accuracy metrics may have the phone within a 10,000 meter range, which is not very helpful at all.

Investigators and analysts can filter by the size of the accuracy range when looking at records to ONLY show records with accuracy ranges that provide more value (900 - 1,000 meters). This can provide a better idea of where the phone is located without having invaluable data wasting your time.

Simply right click on the record and navigate to the filter tab to find the accuracy filter. There you can adjust the accuracy range in order to find the answers you need without the clutter!

All of our users will always run the latest version of **CellHawk**. There is never any software to update or associated fees for new features!

...be on the lookout for upcoming enhanced analytical features!

[30-DAY FREE TRIAL!](#)

- DID YOU KNOW -

FREE RECURRING CELLHAWK TRAINING WEBINAR!

Are you new to **CellHawk** or in need of **CellHawk** refresher training? Do you want to hear about the latest **CellHawk** features and news?

The Hawk Training Team is conducting **FREE** new user/refresher training webinars every other Friday!

We will cover all the features of **CellHawk** and show it in action with a real-life case study. Various file formats and new features will also be covered.

Sharpen your investigative skills or learn new ones. An opportunity will be provided to ask questions of our staff, and a certificate of completion will be provided.

This is a recurring webinar, and each session has a 50-seat capacity so book your seat now.

Schedule Now!

- CASE OF THE QUARTER -



Essex County DA's Office Receives Guilty Plea to a Multi-State ATM Burglary Ring

We are happy to kick off our 2018 Hawk Newsletter with a great *Case of the Quarter* coming from the Massachusetts State Police and the Essex County District Attorney's Office. The investigation began in October 2015 after a report from the Mansfield (MA) Police Department of a burglary that occurred at an Apple retail store. Trooper Mike Murphy, the Massachusetts State Police Gang Unit and numerous other local departments in the New England area investigated the 10 month long case. Assistant District Attorney Phillip Mallard then prosecuted the case. Through their tireless work three men were connected to a multi-state burglary enterprise and subsequently charged and pled guilty to multiple counts of larceny, breaking and entering, conspiracy, and receiving stolen property.

In October 2015 officers from the Mansfield (MA) Police Department responded to an Apple retail store (Simply Mac) to find a hole cut in a neighboring business that led into the Simply Mac store. The break-in was very sophisticated to where the suspects dismantled the video and alarm systems so that police wouldn't respond. Since they could operate their burglary without the worry of a police response, the suspects stole a total of \$119,000 worth of Apple products and were able to get away.

While the burglary was organized and sophisticated, one of the suspects did make a mistake; they linked their own phone number to some of the stolen products.

Later the next year in March, officers in Wellesley, MA responded to a store at 2 a.m. where the same suspects from Mansfield were committing a burglary. The suspects were unable to complete their burglary and evaded police; however, police were able to identify the two vehicles the suspects used to get away. One of these vehicles was registered to one of the suspect's Apple ID address and the name of his significant other. Fingerprints were recovered from the crime scene that confirmed that a second suspect was also at the scene. Both suspects were on probation and their information was

obtained by investigators, including their personal phone numbers.

Utilizing **CellHawk** and its powerful cell site mapping capabilities, Trooper Murphy and ADA Mallard obtained phone records for each suspect's phone number that resulted in over 400,000 records. To complete the analysis manually would have taken weeks, or possibly months. But with the power of **CellHawk**, investigators were able to analyze and map the suspects movements in minutes!

Investigators looked at their pattern of life and noticed irregularities in their movements that were consistent with the two previous break-ins. Investigators contacted those agencies to inquire about any possible burglaries in that area. With **CellHawk's** precise and accurate interpretation of the Call Detail Records (CDRs), investigators were able to connect the men to thirteen burglaries and attempted burglaries of ATMs and commercial businesses.

Mr. Mallard stated the suspects were "disciplined enough" to turn off their cell phones while committing their crimes, but they left their phones on during their scouting trips and could be seen on surveillance video "casing" the stores.

ADA Mallard took the evidence that was mapped by **CellHawk** and presented it in court. It depicted the movements of the suspects through the animation of their phones. The visualization and power of the evidence overwhelmed the defendants to where they had to plead guilty.

Investigators were able to seize over \$82,000 in currency, a 9mm firearm, tools, and half a dozen vehicles that were purchased with stolen money.

Hawk Analytics congratulates ADA Mallard, Trooper Mike Murphy and the numerous other departments for a job well done. The Hawk team truly appreciates the value of our software when we learn of these great cases and how **CellHawk** is instrumental in putting bad guys behind bars.

See the attached [MEDIA RELEASE](#) by the Essex District Attorney's Office.

If you have a case that you would like featured in our newsletter [contact us](#)

- UPCOMING TRAINING -

**Cellular Technology, Mapping and Analysis
&
CellHawk Product Training**

Greater Seattle Area, WA

March 27th - March 29th, 2018

Highline College

Register today by visiting our website at www.hawkanalytics.com/training

OR

contact the [Hawk Training Team](#)

What recent attendees had to say about Hawk training classes:

"Excellent course explaining how the cell technology works and how calls are handled, to include the nuances in CDRs. I have a much better understanding of things and can testify with confidence about the picture the CDRs paint."

"Overall great class. Learned a lot and appreciate the constant reminder of their [Hawk Analytics] willingness to assist on casework."

"Great class, great company, amazing product and outstanding support! Truly thank you for your genuine service!"

Host a Class: Does your agency have a training room? If so your agency can host a class and get FREE seats! For more information email the [Hawk Training Team](#)

- 2017 EVENTS -

Stop by one of the upcoming events and say hi to the Hawk Team and see what's new!



California Homicide Investigators Association Conference
Las Vegas, NV
February 27th - March 1st, 2018



California Police Chiefs Conference
Long Beach, CA
March 18th - March 22nd, 2018



International Association of Law Enforcement Intelligence Analysts
Anaheim, CA
April 9th - April 12th, 2018



International Association of Crime Analysts
Newport Beach, CA
September 17th -September 21st, 2018



October 6-9, 2018
Orange County Convention Center
Orlando, Florida
theIACPconference.org

International Association of Chiefs of Police (IACP)
Orlando, FL
October 6th - October 9th, 2018

- MEET A HAWK -

Nick Barker
Hawk Analytics, Inc. | CellHawk
Marketing Manager
O (469) 373-HAWK (4295) ext. 705



- CONNECT WITH US -



[CELLHAWK DEMO](#)

To Learn More About **CellHawk**

[EMAIL US](#)

469-373-HAWK (4295)

*... forward this email to a friend who should be using **CellHawk!***



Copyright © | 2017, Hawk Analytics | CellHawk, All Rights Reserved.

Our mailing address is:

2652 FM 407 | Suite 215-E | Bartonville, TX 76226

Want to change how you receive these emails?

You can [update your preferences](#) or [unsubscribe from this list](#)

From: Mike Hallinan
Sent: Wednesday, January 31, 2018 1:50 PM PST
To: >PS_Command Staff
Subject: Irvine PD MDC Replacement Recommendation
Attachments: image001.png, image002.png, image003.jpg, image004.png

Command Staff,

As you are aware, our MDC deployment is close to 10 years old, and keeping the aging units functional puts an ever-growing strain on IT and Tech Services resources. The productivity of patrol officers is hindered due to the slow performance and frequent complications with the MDC's. In response, we have spent the last two years extensively researching and testing new MDC solutions. We have spent many hours with multiple vendors finding the ideal MDC device, mounting system and keyboard setup. These solutions have been tested in the field for 6+ months, and feedback has been collected. Based on the results of the field tests and officer feedback, the Panasonic Toughbook FC-33 convertible tablet is the recommended solution for Irvine PD. The FC-33 provides the most flexibility, the newest technology and the highest quality. The proposed solution will increase the amount of physical space in the patrol vehicles storage area by removing all MDC components from the back of the vehicle, it will reduce the time and effort needed to maintain and troubleshoot the devices and it will increase functionality while maintaining the familiar look and feel of the current solution.

Note: The MDC refresh will also include an upgrade to Windows 10. The MDCs that were tested were on Windows 10, and the change did not appear to affect the officers' use.

Recommendation: Panasonic Toughbook FC-33 Convertible Tablet

Benefits of the Panasonic FC-33:

1. The FC-33 is convertible, meaning it can be used as either a tablet or a laptop. While mounted in the unit, the keyboard is folded behind the device giving the appearance and functionality of a tablet. While docked in the unit, the officer will use a permanently mounted keyboard similar to the current solution. If, however, an officer decides to take the MDC out of the unit to use in the field or in the station, the attached keyboard will allow the user to use the device as a laptop. This can come in handy if the officer is away from the vehicle for any amount of time, and needs to have access to a computer.
2. The FC-33 has a squarer 3:2 screen similar to the current solution. This makes the screen taller than the wide screen MDC options. The taller screen is able to display more call notes without the officer needing to scroll down the page. Another benefit is that the screen is narrower, and allows for a better mounting placement and visibility in the vehicles. Additionally, the screen is significantly brighter than the other screens tested.
3. There is no need for external GPS or cellular devices. All MDC components are integrated into the FC-33 mounted in the front of the vehicle. Moving everything to the front of the vehicle allows for more cargo room in the rear of the unit. Furthermore, this integration means that there are fewer components/connections for IT and Tech Services to maintain and troubleshoot.
4. Additional benefits include built-in facial recognition, barcode scanner, ID badge reader, forward/rear cameras, webcam, touchscreen, stylus, and dual batteries.

Comparison and Evaluation

Ultimately, three potential MDCs were evaluated. Two Getac tablets and one Panasonic tablet. All three tablets are relatively similar when it comes to computer specs. They all have the same processor/ram/hard drive options available, and they run Windows 7 and 10. Similarly, they all have dual batteries, are fully rugged, and have internal GPS/LTE/WiFi. Thus, our evaluations focused on screen size/shape/quality, build quality, fit and finish in the vehicles and usability outside of the vehicles.

[cid:image001.png@01D39A9A.73594E30]

[No Keyboards fixed]
[With Keyboards fixed]

Screen

Prior to the new Panasonic FC-33, the only screen shape being produced for ruggedized tablets was wide. During our testing, we realized that the 11.6" widescreen format did not have enough screen real estate for the event notes in MPS. Officers could only read a few lines before needing to scroll. This led us to test the larger 14" screen model. The larger screen did help with the event notes issue, but the large size of the tablet created vehicle fit issues. Panasonic's square design has a longer screen, and allows for easy event note reading. The Panasonic screen is also brighter and has a much higher resolution over the two Getac tablets.

Build Quality

The build quality on the three devices appears to be good, and they appear to be able to handle the constant field use. We have seen issues with Getac batteries, and have had to replace ~10 of them over the last year. Panasonic makes their own batteries with their own technology (Tesla uses Panasonic batteries), and their batteries appear to be superior. The Getac battery issue was a large consideration when deciding on the Panasonic. The smaller Getac's fan is noticeably louder than the other two devices.

Fit and Finish in vehicle

All three devices will fit in the patrol vehicle, and will give enough room to operate the shifter and center dash controls. The smaller Getac tablet allows for the most room, and the larger Getac and Panasonic take up about the same amount of space. The reason is that the dock for the Panasonic is larger than the Getac dock. The smaller Getac dock has had production issues, and we have had to return a considerable number of them. The dock connectors on the smaller Getac are not well designed. Panasonic's mounting system, while bulkier, appears to be more robust. The larger Getac did not have a dock available for testing due to a delay in manufacturing, so it was mounted using a universal mount.

Usability outside of the vehicles

The three devices have very different usability when removed from the vehicles. Below are the notable features.

Small 11.6" Getac F110

1. The Smaller Getac has an attachable keyboard that can turn the tablet into a laptop. The screen on the smaller tablet is not as responsive as the newer devices, so the keyboard is a necessity for undocked use. The keyboard is not attached while docked, so the keyboard would need to be stored somewhere in the vehicle.
2. The smaller tablet does not have a handle, which makes it difficult to carry.

Large 14" Getac A140

1. The larger Getac does not have an available keyboard attachment. As a result, the onscreen keyboard is the only good option. The touchscreen is responsive, so it is possible to use the onscreen keyboard, but it would be difficult to write a report as there is not any tactile feedback, and the onscreen keyboard takes up half of the screen.
2. The Larger Getac does have a handle. This handle can be used as a stand, so using the device on a table is a bit easier.
3. The larger Getac is large and may be a bit too cumbersome when carrying it around. The handle does not stow or lock, so it can get in the way.

Panasonic FC-33

1. The Panasonic has a keyboard that is attached most of the time, and is mounted with the keyboard folded behind. This allows the keyboard to be available at all times. The touchscreen is also responsive, so the user can use the onscreen touchscreen if they do not want to use the keyboard.
2. The Panasonic has a handle that can stow into the keyboard. This handle improves carrying, and acts as stability for the device when in laptop mode.
3. The Panasonic's size and balance makes it the better device for use on a lap or table.
4. The Panasonic is the heaviest of the three MDCs in its anticipated configuration.

Replacement Plan

Scope of Work:

1. Purchase 75 Toughbook CF-33s to replace all Patrol Fleet and ASO MDCs, and to have a few on hand.
 2. Build and configure all devices.
 3. Create training documentation and present new device to briefing.
 4. Have vendor replace the MDCs on all patrol vehicles not being upgraded FY 17/18. The remaining vehicles will be replaced over the following few months.
 - a) Remove old MDC and PDRC from patrol vehicles.
 - b) Replace old Cell and GPS antennas with new GPS/LTE/WiFi antenna.
 - c) Install Gamber Johnson CF-33 Dock and center mounting bracket.
 - d) Replace keyboard with new keyboard (model still to be decided).
-
1. Setup extended support channels for the first week of roll out.

Please let me know if you have any questions or concerns,

Mike

MIKE HALLINAN | COMMANDER
Administrative Services & Support Services Division
Irvine Police Department
1 Civic Center Plaza, Irvine , CA 92606
Direct: 949.724.7110 Email: mhallinan@ci.irvine.ca.us<<mailto:mhallinan@ci.irvine.ca.us>>
[cid:image004.png@01D39A9A.73594E30]

	Getac F110 Unit 43	Getac A140 Unit 44	Panasonic CF-33 Unit 45
Screen Size	11.6"	14"	12"
Screen dimension	Wide	Wide	Square
Screen Brightness	800 nits	1000 nits	1200 nits
Weight	3.1 lbs	5.1 lbs	3.4 lbs (6.1 lbs with keyboard)
Battery	Dual Battery	Dual	Dual
Camera	8mp	8mp	8mp
Facial recognition	No	No	Yes
Smart card reader	Yes	Yes	Yes
2D Barcode Reader	Yes	Yes	Yes
Integrated GPS/LTE/WiFi	Yes	Yes	Yes
Warranty	5 Years	5 years	5 years
Attachable Keyboard	Yes	No	Yes
Handle	No	Yes	Yes
Network Port	No	Yes	Yes
USB ports	1	3	5



Getac F110

Panasonic FC-33

Getac A140



LOANER

PSOPG07001T - 172.16.55.167

USER SUPPORT

Windows 7

TOUGHBOOK

TOUGHBOOK

Getac



Getac

From: Paige at Vigilant
Sent: Monday, February 12, 2018 8:08 AM PST
To: William Hillyard; whillyard@ci.irvine.ca.us
Subject: Upcoming Training Webinars



PlateSearch 101: The Basics Webinar

Tuesday, February 13th 1:00 PM - 2:00 PM EST

Learn about Vigilant's premiere LPR database PlateSearch (previously LEARN), and how to query fixed, mobile and LPR Data to generate case-solving leads. To include basic website navigation and PlateSearch tools License Plate Query, Locate Analysis, & Stakeout. (One hour long)

[Register Now](#)

Other Upcoming Training Webinars:



PlateSearch 202: Advanced Techniques
February 15th 1:00 PM EST

Expanding on skills learned in PlateSearch 101, this course will include advanced LPR querying techniques. Topics featured will be Make & Model and Geo-Fence LPR querying, Common Plate Report, and Associate Analysis. (One hour long)

[Register Now](#)



FaceSearch 101: The Basics
February 28th 1:00 PM EST

Vigilant's Facial Recognition tool FaceSearch will allow users to compare faces across a national database of 16+ million images. Along with basic website navigation, this course will focus on how to upload images for comparison and how best to get a match using filtering and editing techniques. (One hour long)

[Register Now](#)



PlateSearch 202: Advanced Techniques
March 15th 1:00 PM EST

Expanding on skills learned in PlateSearch 101, this course will include advanced LPR querying

techniques. Topics featured will be Make & Model and Geo-Fence LPR querying, Common Plate Report, and Associate Analysis. (One hour long)

[Register Now](#)



FaceSearch 101: The Basics March 22nd 2:30 PM EST

Vigilant's Facial Recognition tool FaceSearch will allow users to compare faces across a national database of 16+ million images. Along with basic website navigation, this course will focus on how to upload images for comparison and how best to get a match using filtering and editing techniques. (One hour long)

[Register Now](#)

[Follow on Twitter](#) [Follow on Facebook](#)

Copyright © 2018 , All rights reserved.

Our mailing address is:

Vigilant Solutions
1152 Stealth Street
Livermore, CA 94551

[unsubscribe from all emails](#) [update subscription preferences](#)

From: Bo Kim
Sent: Monday, February 12, 2018 6:15 PM PST
To: >PS_Crime Analysis; >PS_All Officers
CC: James Hutchcraft; Mark Andreozzi
Subject: Fwd: Upcoming Training Webinars

Good evening all -

Please see below for some upcoming LEARN training webinars. (The descriptions for each webinar are also listed below). Please ignore the Face Search webinar since this is not a function we currently use.

If you choose to participate in the webinars, you will need to use a department desktop computer.

Thank you,
Bo

Begin forwarded message:

From: Paige at Vigilant <bevigilant@vigilantsolutions.com<mailto:bevigilant@vigilantsolutions.com>>
Date: February 12, 2018 at 8:04:40 AM PST
To: <bokim@cityofirvine.org<mailto:bokim@cityofirvine.org>>
Subject: Upcoming Training Webinars
Reply-To: <bevigilant@vigilantsolutions.com<mailto:bevigilant@vigilantsolutions.com>>

[\[http://storage.pardot.com/43142/179754/email_footer_logo.png\]](http://storage.pardot.com/43142/179754/email_footer_logo.png)

[\[http://www2.vigilantsolutions.com/l/43142/2016-08-25/59pcxt/43142/176374/LEARNLPR_Webinar.jpg\]](http://www2.vigilantsolutions.com/l/43142/2016-08-25/59pcxt/43142/176374/LEARNLPR_Webinar.jpg)

PlateSearch 101: The Basics Webinar

Tuesday, February 13th 1:00 PM - 2:00 PM EST

Learn about Vigilant's premiere LPR database PlateSearch (previously LEARN), and how to query fixed, mobile and LPR Data to generate case-solving leads. To include basic website navigation and PlateSearch tools License Plate Query, Locate Analysis, & Stakeout. (One hour long)

Register Now<<http://www2.vigilantsolutions.com/e/43142/register-8751086001791085315/6kt85h/736437004>>

Other Upcoming Training Webinars:

[\[http://www2.vigilantsolutions.com/l/43142/2017-01-11/5jnt8/43142/181127/CarDetector_Control_Room_1.jpg\]](http://www2.vigilantsolutions.com/l/43142/2017-01-11/5jnt8/43142/181127/CarDetector_Control_Room_1.jpg)

PlateSearch 202: Advanced Techniques

February 15th 1:00 PM EST

Expanding on skills learned in PlateSearch 101, this course will include advanced LPR querying techniques. Topics featured will be Make & Model and Geo-Fence LPR querying, Common Plate Report, and Associate Analysis. (One hour long)

Register Now<<http://www2.vigilantsolutions.com/e/43142/register-4663334866185146627/6kt85k/736437004>>

[\[http://www2.vigilantsolutions.com/l/43142/2016-06-18/51pkjr/43142/173704/facesearch_small_2.jpg\]](http://www2.vigilantsolutions.com/l/43142/2016-06-18/51pkjr/43142/173704/facesearch_small_2.jpg)

FaceSearch 101: The Basics

February 28th 1:00 PM EST

Vigilant's Facial Recognition tool FaceSearch will allow users to compare faces across a national database of 16+ million images. Along with basic website navigation, this course will focus on how to upload images for comparison and how best to get a match using filtering and editing techniques. (One hour long)

Register Now<<http://www2.vigilantsolutions.com/e/43142/register-2120356885674169347/6kt85m/736437004>>

[\[http://www2.vigilantsolutions.com/l/43142/2017-01-11/5jpnt8/43142/181127/CarDetector_Control_Room_1.jpg\]](http://www2.vigilantsolutions.com/l/43142/2017-01-11/5jpnt8/43142/181127/CarDetector_Control_Room_1.jpg)

PlateSearch 202: Advanced Techniques

March 15th 1:00 PM EST

Expanding on skills learned in PlateSearch 101, this course will include advanced LPR querying techniques. Topics featured will be Make & Model and Geo-Fence LPR querying, Common Plate Report, and Associate Analysis. (One hour long)

Register Now<<http://www2.vigilantsolutions.com/e/43142/register-8651254744035689731/6kt85p/736437004>>

[\[http://www2.vigilantsolutions.com/l/43142/2016-06-18/51pkjr/43142/173704/facesearch_small_2.jpg\]](http://www2.vigilantsolutions.com/l/43142/2016-06-18/51pkjr/43142/173704/facesearch_small_2.jpg)

FaceSearch 101: The Basics March 22nd 2:30 PM EST

Vigilant's Facial Recognition tool FaceSearch will allow users to compare faces across a national database of 16+ million images. Along with basic website navigation, this course will focus on how to upload images for comparison and how best to get a match using filtering and editing techniques. (One hour long)

Register Now<<http://www2.vigilantsolutions.com/e/43142/register-4096587199601562115/6kt85r/736437004>>

Follow on Twitter<<http://www2.vigilantsolutions.com/e/43142/VigilantSol/6kt85t/736437004>> Follow on

Facebook<<http://www2.vigilantsolutions.com/e/43142/vigilantsolutions-global-/6kt85w/736437004>>

Copyright © 2018 , All rights reserved.

Our mailing address is:

Vigilant Solutions

1152 Stealth Street

Livermore, CA 94551

unsubscribe from all

emails<<http://www2.vigilantsolutions.com/unsubscribe/u/43142/5af95fb5a6ad4625895fe73ef1f4e3e1/736437004>>

update subscription

preferences<<http://www2.vigilantsolutions.com/emailPreference/43142/5af95fb5a6ad4625895fe73ef1f4e3e1/736437004>> <<http://www2.vigilantsolutions.com/e/43142/2018-02-12/6kt85y/736437004>>

[\[http://www2.vigilantsolutions.com/r/43142/1/736437004/open/1\]](http://www2.vigilantsolutions.com/r/43142/1/736437004/open/1)

From: Paige at Vigilant
Sent: Tuesday, March 13, 2018 10:44 AM PDT
To: William Hillyard; whillyard@ci.irvine.ca.us
Subject: Upcoming Training Webinars



PlateSearch 101: The Basics Webinar

Wednesday, March 14th 11:00 AM - 12:00 PM PST

Learn about Vigilant's premiere LPR database PlateSearch (previously LEARN), and how to query fixed, mobile and LPR Data to generate case-solving leads. To include basic website navigation and PlateSearch tools License Plate Query, Locate Analysis, & Stakeout. (One hour long)

[Register Now](#)

Other Upcoming Training Webinars:

More dates are available. [Click here](#) to view the full list
of upcoming training webinars.



PlateSearch 202: Advanced Techniques
March 15th 10:00 AM PST

Expanding on skills learned in PlateSearch 101, this course will include advanced LPR querying techniques. Topics featured will be Make & Model and Geo-Fence LPR querying, Common Plate Report, and Associate Analysis. (One hour long)

[Register Now](#)



FaceSearch 101: The Basics
March 22nd 11:30 AM PST

Vigilant's Facial Recognition tool FaceSearch will allow users to compare faces across a national database of 16+ million images. Along with basic website navigation, this course will focus on how to upload images for comparison and how best to get a match using filtering and editing techniques. (One hour long)

[Register Now](#)



BallisticSearch Training Webinar
April 5th 11:00 AM PST

Learn how BallisticSearch can help you to easily capture images of discharged cartridge cases and

search within the BallisticSearch nationwide gallery of cartridge cases in minutes. Minimize or reduce backlogs that may date back hours, days, weeks, months or years. (One hour long)

[Register Now](#)



Mobile Companion 101: The Mobile Application of PlateSearch

March 19th 11:00 AM PST

Learn about Vigilant's premiere LPR database PlateSearch (previously LEARN), and how to query fixed, mobile and LPR Data to generate case-solving leads on a Mobile device. To include basic navigation and PlateSearch tools License Plate Query, Locate Analysis, & Stakeout. (45 mins long)

[Register Now](#)

[Follow on Twitter](#) [Follow on Facebook](#)

Copyright © 2018 , All rights reserved.

Our mailing address is:

Vigilant Solutions
1152 Stealth Street
Livermore, CA 94551

[unsubscribe from all emails](#) [update subscription preferences](#)

From: Paige at Vigilant
Sent: Tuesday, March 13, 2018 10:44 AM PDT
To: whillyard@ci.irvine.ca.us
Subject: Upcoming Training Webinars



PlateSearch 101: The Basics Webinar

Wednesday, March 14th 11:00 AM - 12:00 PM PST

Learn about Vigilant's premiere LPR database PlateSearch (previously LEARN), and how to query fixed, mobile and LPR Data to generate case-solving leads. To include basic website navigation and PlateSearch tools License Plate Query, Locate Analysis, & Stakeout. (One hour long)

[Register Now](#)

Other Upcoming Training Webinars:

More dates are available. [Click here](#) to view the full list of upcoming training webinars.



PlateSearch 202: Advanced Techniques
March 15th 10:00 AM PST

Expanding on skills learned in PlateSearch 101, this course will include advanced LPR querying techniques. Topics featured will be Make & Model and Geo-Fence LPR querying, Common Plate Report, and Associate Analysis. (One hour long)

[Register Now](#)

FaceSearch 101: The Basics
March 22nd 11:30 AM PST

Vigilant's Facial Recognition tool FaceSearch will allow users to compare faces across a national database of 16+ million images. Along with basic website navigation, this course will focus on how to upload images for comparison and how best to get a match using filtering and editing techniques. (One hour long)

[Register Now](#)



BallisticSearch Training Webinar
April 5th 11:00 AM PST

Learn how BallisticSearch can help you to easily

capture images of discharged cartridge cases and search within the BallisticSearch nationwide gallery of cartridge cases in minutes. Minimize or reduce backlogs that may date back hours, days, weeks, months or years. (One hour long)

[Register Now](#)



Mobile Companion 101: The Mobile Application of PlateSearch

March 19th 11:00 AM PST

Learn about Vigilant's premiere LPR database PlateSearch (previously LEARN), and how to query fixed, mobile and LPR Data to generate case-solving leads on a Mobile device. To include basic navigation and PlateSearch tools License Plate Query, Locate Analysis, & Stakeout. (45 mins long)

[Register Now](#)

[Follow on Twitter](#) [Follow on Facebook](#)

Copyright © 2018 , All rights reserved.

Our mailing address is:

Vigilant Solutions
1152 Stealth Street
Livermore, CA 94551

[unsubscribe from all emails](#) [update subscription preferences](#)

From: Roger Rodriguez
Sent: Tuesday, April 10, 2018 7:16 AM PDT
To: William Hillyard; whillyard@ci.irvine.ca.us
Subject: Man v. Machine- Facial Recognition Webinar- register today!



[ABOUT](#) [SOLUTIONS](#) [CONTACT](#)



FACESEARCH™
WEBINAR

MAN V. MACHINE

[REGISTER NOW](#)

JOIN US

In the past year, facial recognition use by public safety has seen significant improvements in matching accuracy. Although the confidence level in the technology is rising, there are still many best practices they are missing out on such as human involvement, a critical deciding factor of whether returned leads are viable or not. In this webinar, see how Director of Client Relations for Vigilant Solutions and Retired NYPD Detective, Roger Rodriguez uses Vigilant's FaceSearch to generate investigative leads from images that normally do not meet the criteria for facial recognition searching after vetting and performing specific enhancements.

Register for our webinar: Man v. Machine, and we will explain why the facial recognition process still needs human involvement.

REGISTER NOW

WHEN

Thursday, April 19, 2018 | 3:00 PM - 4:00 PM EDT

HOSTS

Roger Rodriguez

Director of Client Relations, Vigilant Solutions

Detective, NYPD (RET.)

REGISTER NOW



BE SAFE. BE SMART. BE VIGILANT.

VigilantSolutions.com | 925-398-2079



[Vigilant Solutions](#), 1152 Stealth Street, Livermore, CA 94551, 925-398-2079

[Unsubscribe](#)

From: Roger Rodriguez
Sent: Wednesday, April 18, 2018 8:33 AM PDT
To: whillyard@ci.irvine.ca.us
Subject: Man v. Machine- Facial Recognition Webinar- sign up today!



[ABOUT](#) [SOLUTIONS](#) [CONTACT](#)



FACESEARCH™
WEBINAR

MAN V. MACHINE

[REGISTER NOW](#)

JOIN US

In the past year, facial recognition use by public safety has seen significant improvements in matching accuracy. Although the confidence level in the technology is rising, there are still many best practices they are missing out on such as human involvement, a critical deciding factor of whether returned leads are viable or not. In this webinar, see how Director of Client Relations for Vigilant Solutions and Retired NYPD Detective, Roger Rodriguez uses Vigilant's FaceSearch to generate investigative leads from images that normally do not meet the criteria for facial recognition searching after vetting and performing specific enhancements.

Register for our webinar: Man v. Machine, and we will explain why the facial recognition process still needs human involvement.

REGISTER NOW

WHEN Thursday, April 19, 2018 | 3:00 PM - 4:00 PM EDT

HOSTS **Roger Rodriguez**
Director of Client Relations, Vigilant Solutions
Detective, NYPD (RET.)

REGISTER NOW



BE SAFE. BE SMART. BE VIGILANT.

VigilantSolutions.com | 925-398-2079



Vigilant Solutions, 1152 Stealth Street, Livermore, CA 94551, 925-398-2079

[Unsubscribe](#)

From: Paige at Vigilant
Sent: Tuesday, April 24, 2018 4:46 PM PDT
To: whillyard@ci.irvine.ca.us
Subject: Upcoming Training Webinars



PlateSearch 101: The Basics Webinar

Thursday, April 26th 11:30 AM - 12:30 PM PST

Learn about Vigilant's premiere LPR database PlateSearch (previously LEARN), and how to query fixed, mobile and LPR Data to generate case-solving leads. To include basic website navigation and PlateSearch tools License Plate Query, Locate Analysis, & Stakeout. (One hour long)

[Register Now](#)

Other Upcoming Training Webinars:

More dates are available. [Click here](#) to view the full list

of upcoming training webinars.

Other Upcoming Training Webinars:



PlateSearch 202: Advanced Techniques

May 10th 10:00 AM PST

Expanding on skills learned in PlateSearch 101, this course will include advanced LPR querying techniques. Topics featured will be Make & Model and Geo-Fence LPR querying, Common Plate Report, and Associate Analysis. (One hour long)

[Register Now](#)



FaceSearch 101: The Basics

April 26th 10:00 AM PST

Vigilant's Facial Recognition tool FaceSearch will allow users to compare faces across a national database of 16+ million images. Along with basic website navigation, this course will focus on how to upload images for comparison and how best to get a match using filtering and editing techniques. (One hour long)

[Register Now](#)



PlateSearch 202: Advanced Techniques

June 14th 10:00 AM PST

Expanding on skills learned in PlateSearch 101, this course will include advanced LPR querying techniques. Topics featured will be Make & Model and Geo-Fence LPR querying, Common Plate Report, and Associate Analysis. (One hour long)

[Register Now](#)



FaceSearch 101: The Basics

May 24th 10:00 AM PST

Vigilant's Facial Recognition tool FaceSearch will allow users to compare faces across a national database of 16+ million images. Along with basic website navigation, this course will focus on how to upload images for comparison and how best to get a match using filtering and editing techniques. (One hour long)

[Register Now](#)

[Follow on Twitter](#) [Follow on Facebook](#)

Copyright © 2018 , All rights reserved.

Our mailing address is:

Vigilant Solutions
1152 Stealth Street
Livermore, CA 94551

[unsubscribe from all emails](#) [update subscription preferences](#).

From: Roger Rodriguez
Sent: Friday, June 1, 2018 9:08 AM PDT
To: whillyard@cityofirvine.org
Subject: Back By Popular Demand: Man v. Machine - Facial Recognition Webinar!



[ABOUT](#) [SOLUTIONS](#) [CONTACT](#)



FACESEARCH™
WEBINAR

MAN V. MACHINE

[REGISTER NOW](#)

JOIN US

In the past year, facial recognition use by public safety has seen significant improvements in matching accuracy. Although the confidence level in the technology is rising, there are still many best practices they are missing out on such as human involvement, a critical deciding factor of whether returned leads are viable or not. In this webinar, see how Director of Client Relations for Vigilant Solutions and Retired NYPD Detective, Roger Rodriguez uses Vigilant's FaceSearch to generate investigative leads from images that normally do not meet the criteria for facial recognition searching after vetting and performing specific enhancements.

Miss the first installment? We've opened registration for another round. Register for our webinar: **Man v. Machine** and we will explain why the facial recognition process still needs human involvement.

REGISTER NOW

WHEN

Thursday, June 14, 2018 | 3:00 PM - 4:00 PM EDT

HOSTS

Roger Rodriguez

Director of Client Relations, Vigilant Solutions

Detective, NYPD (RET.)

REGISTER NOW



BE SAFE. BE SMART. BE VIGILANT.

VigilantSolutions.com | 925-398-2079



Vigilant Solutions, 1152 Stealth Street, Livermore, CA 94551, 925-398-2079

[Unsubscribe](#)

From: Roger Rodriguez
Sent: Wednesday, June 6, 2018 9:04 AM PDT
To: whillyard@cityofirvine.org
Subject: Have You Registered Yet? Man v. Machine - Facial Recognition Webinar!



[ABOUT](#) [SOLUTIONS](#) [CONTACT](#)



FACESEARCH™
WEBINAR

MAN V. MACHINE

[REGISTER NOW](#)

JOIN US

In the past year, facial recognition use by public safety has seen significant improvements in matching accuracy. Although the confidence level in the technology is rising, there are still many best practices they are missing out on such as human involvement, a critical deciding factor of whether returned leads are viable or not. In this webinar, see how Director of Client Relations for Vigilant Solutions and Retired NYPD Detective, Roger Rodriguez uses Vigilant's FaceSearch to generate investigative leads from images that normally do not meet the criteria for facial recognition searching after vetting and performing specific enhancements.

Miss the first installment? We've opened registration for another round. Register for our webinar: **Man v. Machine** and we will explain why the facial recognition process still needs human involvement.

[REGISTER NOW](#)

WHEN Thursday, June 14, 2018 | 3:00 PM - 4:00 PM EDT

HOSTS **Roger Rodriguez**
Director of Client Relations, Vigilant Solutions
Detective, NYPD (RET.)

[REGISTER NOW](#)



BE SAFE. BE SMART. BE VIGILANT.

VigilantSolutions.com | 925-398-2079



Vigilant Solutions, 1152 Stealth Street, Livermore, CA 94551, 925-398-2079

[Unsubscribe](#)

From: Paige at Vigilant
Sent: Friday, June 8, 2018 6:32 AM PDT
To: whillyard@ci.irvine.ca.us
Subject: Upcoming Training Webinars



PlateSearch 101: The Basics Webinar

Tuesday, June 12th 11:30 AM - 12:30 PM PST

Learn about Vigilant's premiere LPR database PlateSearch (previously LEARN), and how to query fixed, mobile and LPR Data to generate case-solving leads. Topics include basic website navigation, PlateSearch tools, License Plate Query, Locate Analysis and Stakeout. (One hour long).

[Register Now](#)

Additional Dates:

More dates are available. [Click here](#) to view the full list

of upcoming training webinars.

Other Upcoming Training Webinars:



PlateSearch 202: Advanced Techniques

June 14th 10:00 AM PST

Expanding on skills learned in PlateSearch 101, this course will include advanced LPR querying techniques. Topics featured will be Make & Model and Geo-Fence LPR querying, Common Plate Report, and Associate Analysis. (One hour long)

[Register Now](#)

FaceSearch 101: The Basics

June 12th 10:00 AM PST

Vigilant's Facial Recognition tool FaceSearch will allow users to compare faces across a national database of 16+ million images. Along with basic website navigation, this course will focus on how to upload images for comparison and how best to get a match using filtering and editing techniques. (One hour long)

[Register Now](#)



Mobile Companion 101: The Mobile Application of PlateSearch

June 27th 10:00 AM PST

Learn about Vigilant's premiere LPR database PlateSearch (previously LEARN), and how to query fixed, mobile and LPR Data to generate case-solving leads on a Mobile device. To include basic navigation and PlateSearch tools License Plate Query, Locate Analysis, & Stakeout. (45 mins long).

[Register Now](#)



PlateSearch 101: The Basics

June 28th 11:30 AM PST

Learn about Vigilant's premiere LPR database PlateSearch (previously LEARN), and how to query fixed, mobile and LPR Data to generate case-solving leads. opics include basic website navigation, PlateSearch tools, License Plate Query, Locate Analysis and Stakeout. (One hour long).

[Register Now](#)

[Follow on Twitter](#) [Follow on Facebook](#)

Copyright © 2018 , All rights reserved.

Our mailing address is:

Vigilant Solutions
1152 Stealth Street
Livermore, CA 94551

[unsubscribe from all emails](#) [update subscription preferences](#).

From: Roger Rodriguez
Sent: Tuesday, June 12, 2018 9:14 AM PDT
To: whillyard@cityofirvine.org
Subject: It's not too late to register for Man v. Machine - Facial Recognition Webinar!



[ABOUT](#) [SOLUTIONS](#) [CONTACT](#)



FACESEARCH™
WEBINAR

MAN V. MACHINE

[REGISTER NOW](#)

JOIN US

In the past year, facial recognition use by public safety has seen significant improvements in matching accuracy. Although the confidence level in the technology is rising, there are still many best practices they are missing out on such as human involvement, a critical deciding factor of whether returned leads are viable or not. In this webinar, see how Director of Client Relations for Vigilant Solutions and Retired NYPD Detective, Roger Rodriguez uses Vigilant's FaceSearch to generate investigative leads from images that normally do not meet the criteria for facial recognition searching after vetting and performing specific enhancements.

Miss the first installment? We've opened registration for another round. Register for our webinar: **Man v. Machine** and we will explain why the facial recognition process still needs human involvement.

[REGISTER NOW](#)

WHEN Thursday, June 14, 2018 | 3:00 PM - 4:00 PM EDT

HOSTS **Roger Rodriguez**
Director of Client Relations, Vigilant Solutions
Detective, NYPD (RET.)

[REGISTER NOW](#)



BE SAFE. BE SMART. BE VIGILANT.

VigilantSolutions.com | 925-398-2079



Vigilant Solutions, 1152 Stealth Street, Livermore, CA 94551, 925-398-2079

[Unsubscribe](#)

From: Shawn Smith
Sent: Wednesday, June 13, 2018 9:11 AM PDT
To: whillyard@cityofirvine.org
Subject: Vigilant Solutions Acquisition Announcement



[ABOUT](#) [SOLUTIONS](#) [CONTACT](#)



VIGILANT SOLUTIONS ACQUISITION ANNOUNCEMENT

Dear William,

We are very excited to announce today that [Vigilant Solutions has acquired the assets of ShotCaller Global Inc.](#), developer of GunOps™ and DNAOps™ investigative solutions for law enforcement. This acquisition enables us to provide the law enforcement community with firearm forensic mapping and DNA crime mapping technology that complement our existing suite of automated license plate reader (ALPR) data, facial recognition technology and ballistics analysis solutions.

GunOps and DNAOps are web-based interactive investigation tools. GunOps allows law enforcement investigators and analysts to enter, visualize and access information about firearm-related crimes, forensic test results and armed criminals. DNAOps allows law enforcement to enter, visualize and access information about crimes where DNA has been recovered from crime scenes, using web-based mapping applications.

This means Vigilant Solutions is now well-positioned to help the law enforcement community to combat the growing epidemic of gun crime. Specifically, our enhanced suite of offerings enables us to provide law enforcement the ability to help identify the G.E.T. – geography, event and time – of gun crime.

Anyone who works with or for Vigilant Solutions knows that we are passionate about the fact that our solutions help to keep communities and law enforcement safe. This acquisition is exciting because it not only allows us to continue to achieve that goal, but also enables us to expand our capabilities and help law enforcement to eradicate violent gun crime.

If you are interested in learning more about GunOps, please contact us at BeVigilant@VigilantSolutions.com.

Be Safe. Be Smart. Be Vigilant.

Shawn Smith
Founder and President



BE SAFE. BE SMART. BE VIGILANT.

VigilantSolutions.com • 925-398-2079



Vigilant Solutions, 1152 Stealth Street, Livermore, CA 94551, 925-398-2079

[Unsubscribe](#)

From: Special Services Group Info
Sent: Tuesday, June 19, 2018 3:22 PM PDT
To: Jeff Godfrey
Subject: SSG Black Book and Equipment Demos
Attachments: SSGBlackBook2018v5.pdf, image003.jpg, image004.png, image005.jpg

Please see correction, your Sales Director is Jeff Godfrey.



Special Services Group, LLC

PO Box 825, Denair, CA 95316

Phone: (209) 682-5026

Fax: (209) 634-4426

www.specialservicesgroup.us

This email and any attachments thereto, contains confidential and/or trade secret information that is not intended or authorized for public disclosure and is provided strictly on the basis that the confidentiality of this information will be protected by its recipient from any unauthorized disclosure. This communication is intended to be confidential and solely for use of the persons or entities addressed above. If you are not an intended recipient, be aware that the information contained herein may be protected from unauthorized use by privilege or law, and any copying, distribution, disclosure, or other use of this information is prohibited. This communication and any attachments may contain EXPORT-CONTROLLED technical data that is subject to the International Traffic In Arms Regulations (ITAR), or the Export Administration Regulations (EAR). Export of this material is prohibited without a valid export license issued by the US Department of State, Office of Defense Trade Controls as prescribed in the International Traffic in Arms Regulations, Title 22, Code of Federal Regulations, Parts 120-130. If you have received this communication in error, please contact the sender by return e-mail or telephone the above number immediately and delete or destroy all copies. Thank you for your cooperation.

From: Special Services Group Info
Sent: Tuesday, June 19, 2018 3:17 PM
To: 'Jeff Godfrey' <jgodfrey@specialservicesgroup.us>
Subject: SSG Black Book and Equipment Demos

Greetings!

Our sales director for your area, Jeff Godfrey, is scheduling in-person demonstrations of our equipment. Please take a look at our latest catalog and let us know if you'd like to be contacted to schedule an in-person demonstration at your office.

Best Regards,



Special Services Group, LLC

PO Box 825, Denair, CA 95316

Phone: (209) 682-5026

Fax: (209) 634-4426

www.specialservicesgroup.us

This email and any attachments thereto, contains confidential and/or trade secret information that is not intended or authorized for public disclosure and is provided strictly on the basis that the confidentiality of this information will be protected by its recipient from any unauthorized disclosure. This communication is intended to be confidential and solely for use of the persons or entities addressed above. If you are not an intended recipient, be aware that the information contained herein may be protected from unauthorized use by privilege or law, and any copying, distribution, disclosure, or other use of this information is prohibited. This communication and any attachments may contain EXPORT-CONTROLLED technical data that is subject to the International Traffic In Arms Regulations (ITAR), or the Export Administration Regulations (EAR). Export of this material is prohibited without a valid export license issued by the US Department of State, Office of Defense Trade Controls as prescribed in the International Traffic in Arms Regulations, Title 22, Code of Federal Regulations, Parts 120-130. If you have received this communication in error, please contact the sender by return e-mail or telephone the above number immediately and delete or destroy all copies. Thank you for your cooperation.



BLACK BOOK

Real World Operability

Technical solutions for law enforcement, military, intelligence and select clients.
www.specialservicesgroup.us

2018

Table of Contents

PRODUCTS	PAGE(S)
Video Surveillance – Miniature Video Compression Devices.....	3-5
Video Surveillance—Cameras & Concealments	6-7
Video Surveillance—Pinhole Cameras & Lenses	8-10
Video Surveillance—Low Light Analog Cameras & Lens Adapters	11
Video Surveillance—Recording & Transmission.....	12
Video Surveillance—Pole and Streetlight Cams.....	13
Video Surveillance—Vehicle Camera Mount.....	14
Video Surveillance—Field Camera Kits.....	15
Video Surveillance—Field Camera Concealments	16
Power & Solar Equipment.....	17-20
Audio Transmitters & Receivers	21-23
Audio & Video Transmitters	24-25
Audio Capture Equipment.....	26-27
Night Vision Equipment.....	28
Infrared Optical Beacons.....	29-30
Radio Frequency (RF) Tracking.....	31
GPS Tracking.....	32
Covert Access Equipment.....	33-35



SPECIAL SERVICES GROUP

Miniature Video Compressor (MVC™)

The SSG Miniature Video Compressor (SSGMVC™) line represents a breakthrough in cellular connected video. The small form factor and low power consumption allow the SSGMVC devices to be used in concealments where previous compressor offerings have been excluded due to size, weight and power.



The SSGMVC-DM12™ Dual Camera Compressor's pair of integrated 5-megapixel MIPI imagers give the lowest power consumption of all SSGMVC variants. Mounted behind M12 lens barrels, these allow two lenses of differing focal lengths to be used, proving dual, simultaneous video feeds across the cellular network. A miniature “drop and go” system with modem, compressor and recorder all in one.



The SSGMVC-ETH™ Inline Compressor has a single ethernet connector and USB port. The device can be used with COTS USB modem products from a range of manufacturers; or, with the addition of a USB-Ethernet adaptor, the SSGMVC-ETH can be used in line between existing IP cameras and secure infrastructure 4G modems (such as offerings from Sierra Wireless and Cradlepoint).

i

Turnkey server options are available to include ready-to-go cloud storage making the device plug and play without any coordination of agency IT resources.

*For more information or a price quote:
Email - sales@specialservicesgroup.us
Call - (209) 682-5026*

SSGMVC-PTZ™

All-in-One Miniature PTZ Camera with Compressor, Modem and Recorder

Built to further increase the SSG Miniature Video Compressor integration level, the SSGMVC-PTZ camera brings pan and tilt functionality, dual sensor imaging and the SSGMVC video compressor together, in a tiny 2.1" diameter device, perfect for concealments.

A pair of integrated 5-megapixel MIPI imagers, mounted to a custom, encoded pan and tilt mechanism, allow the user to steer the camera onto target. Two imagers are used to give varying levels of magnification to the user. The wide lens is used to target the camera and the tele lens provides sufficient magnification to provide identification at ranges out to 300ft.

Integrated within the housing is the SSGMVC video compressor, designed with an internal modem, or for use with an external COTS USB modem. The unit's external USB host port also allows direct connection to a multitude of infrastructure, including cellular, mesh and satcom options. The SSGMVC-PTZ also comes with an onboard SD card recorder, making the hand-held device all you need for PTZ video, compression, transmission and storage.

The SSGMVC-PTZ brings everything needed for video surveillance to the palm of your hand. With its miniature size and incredibly low power draw, nothing compares to the SSGMVC-PTZ. You no longer need to run multiple devices such as compressors, routers/modems and NVR's... the SSGMVC-PTZ does it all, at only a fraction of the size, weight, power and cost!

The SSGMVC-PTZ unit measures 2.2 x 2.2 x 4.5" and consumes less than 3.5W of power with integrated modem.



i

No special SIM cards are required for operation. Turnkey server options are available to include ready-to-go cloud storage making the device plug and play without any coordination of agency IT resources.

SSGMVC-LHC™ Lamp Head Concealment



The SSG Miniature Video Compressor Lamp Head Concealment (SSGMVC-LHC) is the first in SSG's line of Miniature Video Compressor Concealments. The breakthrough technology in the MVC allows SSG to provide innovative video compression concealments never before available due to size and power restrictions.

The Lamp Head Concealment is built from the ground up to be a plug-in replacement for standard street lamp day / night sensors. The concealment directly connects to the NMEA power socket present on most street lamp fixtures. The device takes its power from this socket, and replaces the functionality of the original sensor, turning the street lamp on and off based on the ambient lighting conditions.

A pair of integrated 5-megapixel MIPI imagers, mounted to a custom pan and tilt mechanism, allow the user to steer the camera onto target. Two imagers are used to give varying levels of magnification to the user.

The device is built with the SSG Miniature Video Compressor, modem, and recorder all integrated, creating a miniature concealment/ recording/ compression/transmission device like no other!

i

Turnkey server options are available to include ready-to-go cloud storage making the device plug and play without any coordination of agency IT resources.

*For more information or a price quote:
Email - sales@specialservicesgroup.us
Call - (209) 682-5026*

Rapid Vehicle Deployment Kits

IP Baby Seat Drop Kit

The SSG IP Baby Seat Drop Kit consists of everything you need to quickly and covertly deploy a drop car for video surveillance. The IP Baby Seat houses a high definition IP camera with incredible zoom. The Baby Seat concealment has front, rear and side viewing angles due to the camera's full 360° PTZ rotation. The system is fully portable, so you are not restricted to the same drop car for each mission.

The IP Baby Seat comes in a variety of custom kits, including our self-contained "All-in-one" kit. Kits can be custom configured to include camera only, or camera with video recording and transmission systems and power supply.

Flashing Amber Beacon PTZ Rapid Deploy Kit

The Amber Beacon Camera is a working, flashing, amber emergency beacon that can be mounted to the top of a vehicle by suction, magnets or fixed mount. The Amber Beacon is a full 360° rotation PTZ color camera providing views of the entire surrounding area. With suspects now showing awareness of surveillance vans with periscope cameras, the Amber Beacon is the perfect solution for covert vehicle based surveillance. The camera inside the Amber Beacon is a completely concealed discreet remote viewing device. The camera is also fully functional, with or without the amber light flashing.

The Amber beacon is available as a camera alone, or in a rapidly deployable kit with everything a user needs for a complete surveillance solution.



Tombstone Cam

The Tombstone Cam is our newest video concealment offering the ability to conduct remote surveillance operations from cemeteries. The Tombstone is offered as a concealment only, or as a complete all-in-one system with PTZ video, edge recording, optional audio, and full power. The all-inclusive system can be deployed for approximately two days with the included PB-180[®] LiFePO₄ battery. The Tombstone Cam is fully portable and can be easily moved from location to location as necessary.



The FLY Alarm Clock Camera and Audio Transmitter

The “Fly on the Wall” is a working Memorex clock radio designed to capture and record video and audio and transmit it via a secure encrypted Wi-Fi signal to a nearby location. The Fly was designed for vice operations, drug buys, covert home or office deployments, and hotel room stings. Up to ten investigators can watch and listen to the live audio and video by simply connecting to the WiFi network on their smart phones, notepads, or laptops. The video and audio is constantly recording to an SD card on the device itself.



Shop-Vac Covert DVR Recording System

The Shop-Vac is a fully contained high definition PTZ IP camera, DVR and battery housed in a covert Shop Vac concealment. A battery is included inside for short deployments. An AC power connector is available for long-term deployments, and DC power options can be connected for mobile deployments also. The high definition camera has a 20x optical zoom and exceptional low light capability. The system also houses a cellular gateway for full remote video transmission and Wi-Fi for nearby connectivity. Also included is a keyfob for remote resets, and 1TB of recording storage on the internal DVR. The system is compatible with Milestone, View Commander or many other video management software options.



*For more information or a price quote:
Email - sales@specialservicesgroup.us
Call - (209) 682-5026*

Flexible Alignment (FA) Lenses

Standard pinhole lenses suffer from two main problems. First, the aperture of the lens needs to be positioned right in the pinhole, making the presence of the camera easy to detect. Second, the alignment of the lens to the pinhole is critical; any slight misalignment causes vignetting. FA lenses use novel optical technology to overcome both of these problems.



FA Pinhole Camera Kit

- Focal Length: 4.8mm to 29mm
- Field of View: 12° to 65°
- Stand-off distance : 2mm typ.
- Camera: S Mount 1/3" typ.



FA 120 Wide Angle Pinhole Kit

- Focal Length: 1.8mm
- Field of View: 120°
- Stand-off distance : 2mm typ.
- Camera: S Mount 1/3" typ.



Miniature Flexible Alignment Camera & Miniature Flexible Alignment - Right Angle Pinhole Camera



The Miniature Flexible Alignment Pinhole camera/lens combination is the latest addition to the FA range of optical surveillance solutions. This provides a 12, 25 or 50 degree field of view through a 1mm pinhole, optimized for deployment in extremely confined spaces. Use of a 1/3.7" sensor keeps the overall diameter under 9mm, while still providing superior low light performance, essential in pinhole installations.



Angled Pinhole (AP) Camera / Lens Kit

The Angled Pinhole Camera Kit allows surveillance operatives to observe an area of interest centered 45 degrees off axis to a pinhole cut through a ceiling or wall at right angles. This simple to install lens provides a 30 degree field of view (FoV) and is pointed by simply rotating the lens during installation. In addition, the lens stands back 2mm from the small 1.2mm pinhole, reducing the risk / of detection.



HD & Ultra Low Light Camera with HD

The HD & Ultra Low Light Camera with HD 100mm Compact Telephoto lens kit (HDULL100) provides a 24/7 solution to capture covert surveillance footage. The kit is based around Claresys latest development - The High Definition 100mm Compact Telephoto lens. By increasing the lens aperture, we have been able to achieve f/4 stop which is ideal for capturing images in low light, while still maintaining the extremely small form factor compared to traditional surveillance lenses. Paired with Claresys Ultra Low Light Camera, footage can be acquired in near total darkness thanks to its 0.000005 lux sensitivity. The HD camera also included in the kit allows for higher resolution image capture when required such as facial recognition or vehicle license plates.

Compact Optically Scanning Enhanced (COSE) Zoom Pinhole Lens

COSE 120DL



COSE 120ST



Using a patented optical scanning technique the COSE lens offers up to 120° pan, tilt and 10x zoom capability through a 1mm pinhole with no lens movement. It can scan and zoom onto any target subject within the wide angle field of view of the lens. The scanning is purely optical meaning full image brightness and quality are preserved. COSE can be easily integrated with many cameras and control systems.



HDCT100 with HD SDI Camera



HDCT100 with Ultra Low Light Camera

*For more information or a price quote:
Email - sales@specialservicesgroup.us
Call - (209) 682-5026*

Compact Telephoto (CT) Lenses

The Compact Telephoto lens range has been developed to address an operational need for longer focal lengths while minimizing the overall combined size of the lens/camera package to facilitate hiding in concealments. The length of the lens is kept to a minimum using a unique design to achieve extreme telephoto ratios, typically 60%. The lenses have been optimized for use with small, low cost S-mount (M12x0.5) board and bullet cameras, further helping to keep the overall installation size to a minimum.



- Focal Length: 250mm
- Length: 144mm
- Diameter: 31mm
- Camera: S Mount (M12x0.5)
- 1/3" sensor
- Resolution: >570 TV lines

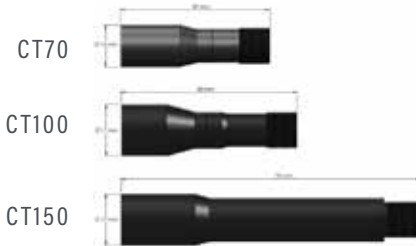

- Focal Length: 70mm, 100mm, 150mm
- Length: 49mm to 99mm
- Diameter: 14mm to 17mm
- Camera: S Mount (M12x0.5)
- 1/3" sensor
- Resolution: >570 TV lines



HIPATZ

The Claresys High Definition Internal Pan, Tilt and Zoom Lens is a remote surveillance camera/lens solution with a unique internal optical scanning capability that provides covert pan and tilt operation and 35x zoom. This allows the user to scan across a scene without the camera or lens moving, as all PTZ functions are internal. The HIPATZ provides high quality video surveillance combined with fast and easy deployment for hostile or exposed locations. The HIPATZ is easy to conceal in a covert hide or buried in the ground, simplifying the deployment and helping to reduce complexity and power requirements.



Watec 910HX Ultra Low Light Camera

The Watec 910HX is a monochrome ultra low light camera. This camera is equipped with built-in video motion detection with an alarm output terminal to trigger external devices such as a DVR.

- Low Light Sensitivity/0.000005 lux
- Dead Pixels Correction
- 3D Noise Reduction (3DNR)
- Motion Detection
- On Screen Display
- Weight – 2.9oz (83g)
- Digital Wide Dynamic Range



Board Level Option



S/C Mount Lens Adapter Kit

The SSG S/C Mount Lens Adapter Kit includes the following items:

- S-Mount to C-Mount Adapter—Flat
- S-Mount to C-Mount Adapter—Medium
- S-Mount to C-Mount Adapter—High
- C-Mount Lock Ring
- M12/S-Mount Lock Ring
- Allen Wrench

For more information or a price quote:

Email - sales@specialservicesgroup.us

Call - (209) 682-5026

Drop Box Recording and Observation Covert System

The Drop Box recording and transmission system is a ruggedized case housing a network DVR for local recording, a cellular gateway for video transmission, options for COFDM transmission if desired, high power Wi-Fi, and a monitor for local viewing and control. The Drop Box has connections for IP and analog cameras, allowing almost any camera to be connected to the external ports on the box. There is also an external connector for a DC battery source or from a power cord with the included 120v AC power supply. The Drop Box can be left in drop cars, surveillance vans, offices, motels, etc., and can also be used as a monitoring device for smaller cameras used in hotel room stings. The Drop Box is a multi-function versatile recording and transmission system that is suitable for almost any video surveillance mission.

- Replaces high-cost surveillance vans that easily get burned.
- Can be moved quickly and easily from vehicle to vehicle.
- Remote access options via cellular, WiFi or COFDM if desired.
- Run multiple cameras simultaneously.
- Can be monitored onsite, if desired, or remotely.
- Built with latest Sierra Wireless RV50 modem.
- Plug and play with PB-180® power systems.



Pole and Streetlight Cameras

SSG offers a full line of pole and streetlight cameras. Our cameras include micro-sized pole cameras, NVR based systems with onboard recording, innovative Cable Boot concealments that hang mid line, as well as overt solutions.

Various options available:

- High definition IP based PTZ cameras
- Covert and overt options
- Onboard recording w/built-in NVR
- Dual camera pole box systems
- Remote recording Video Management Systems
- Choice of cameras (Canon, Axis, Panasonic, Sony, Hikvision)
- Smallest footprint 6" x 8"
- Wi-Fi, cellular, COFDM
- GSM , CDMA or Cable
- Remote key-fob reset
- DNS service
- 12V DC or 120-240V AC power options



Pole (NEMA) box power supplies available - see Power & Solar Equipment section of catalog

*For more information or a price quote:
Email - sales@specialservicesgroup.us
Call - (209) 682-5026*

Vehicle Camera Mount

The Vehicle Cam Mount allows you to use your traditional outdoor IP pole cameras for in-vehicle or other indoor deployments. The mount comes with:

- **Telescoping Pole** - Spring loaded 2-section aluminum poles with a unique spring locking expansion system locks the mounting pole between the ceiling and the floor, or two walls, resulting in a quick, non-permanent mounting solution that only has a footprint of two inches in diameter.
- **Adjustable Clamp** - The adjustable clamp is made from a lightweight alloy that will support loads of up to 44 lbs. It features a hexagonal receiver that accepts dozens of accessories from a simple stud to the versatile Max Arm to mount almost any light fixture, camera or accessory. The receiver features a spring locking safety system to ensure that the accessory won't separate from the clamp if the locking screw loosens unexpectedly. It also features a saddle to securely mount it on flat surfaces. This clamp has a ratcheted handle that allows you to reposition it should you not have clearance to rotate the handle in a complete circle to tighten or loosen it.
- **Powder Coated Steel Mounting Plate** - Mounting plate is a heavy-duty steel plate powder coated black and used to allow for quick mounting and placement of the PTZ camera of choice. The mounting plate is connected to the adjustable clamp to provide easy mounting and placement of a PTZ camera on the expandable mounting pole.
- **Camera Specific Magnet Adapter** - The magnet adapter is a custom CNC machined high density plastic that connects to a PTZ IP camera such as the Canon VB-M44, H45, M50 line of cameras as well as the Axis V59 series cameras. The adapter uses the standard ¼-20 mount on a PTZ camera and three rare-earth magnets that provide a positive connect to the steel mounting plate. The camera is completely secure, yet easy to remove or adjust.





Reconyx Cellular Camera Kit

- 1 Reconyx 750 or 950 Camera (Cellular Version Only)
- Custom Storm case
- 2 16GB SD cards
- NiMH rechargeable batteries and charger
- Covert camera hide



Reconyx SC950 Cellular HyperFire Covert Security Camera

Excellent picture quality day and night with covert “no-glow” IR. Onboard recording to 32GB SD card. Options include loop recording, scheduled by time of day and day of week. The

cellular feature allows the camera to send photos to your smart device.



Reconyx SM750 Cellular HyperFire License Plate Capture Camera

Captures license plate images at speeds as fast as 3 frames per second on vehicles traveling at speeds of up to 50 miles per hour. Quality day and night

recording with “no-glow” IR. Includes loop recording, scheduled by time of day and day of week. The cellular feature allows your camera to send photos to your smart device.



HS2X Hyperfire 2 Security Covert IR Camera

The NEW HS2X Security Series Camera is equipped with features such as Loop Recording (overriding beginning images so the camera will continue to record once the memory card is filled)

and Advanced Multi-Scheduling (programming the camera to only operate during set hours of the day and different days of the week). The HS2X has a 1/4th second trigger speed coupled with motion sensing. NoGlow™ GEN3 High Output Infrared night vision reaches out to 150 feet. The new image sensor provides HD images and videos. The nighttime images are crisp and clear with no graininess or blurring, while the daytime photos are rich in color and clarity.



Reconyx MS8/MS7 MicroFire WiFi Enabled Security Camera

GEN2 NoGlow covert infrared illumination up to 50 feet with 720P HD video w/audio. 0.2 second trigger speed. All controls reside securely on your smartphone or tablet via

a free mobile app for Android or iOS devices (certain restrictions apply). You can check camera status, change programming options and download images and videos wirelessly from up to 100 feet away. The MS8 Security Camera boasts features such as loop recording, multi-scheduling, and audio on/off. MS7 version captures license plates on vehicles traveling up to 50 mph.



Reconyx XS8 UltraFire Covert General Surveillance Camera

GEN2 NoGlow covert infrared illumination up to 80 feet with 1080P HD video at 30 frames per second. Still image resolution up to 8 megapixels. 2.4” color display allows

playback of images and sound directly on the camera. Loop and scheduled recording options. Audio option.

For more information or a price quote:

Email - sales@specialservicesgroup.us

Call - (209) 682-5026

Rock & Tree Concealments

For Reconyx 950 & 750 Cellular,
XR6 and XS8 Cameras

High quality, weather proof silicone rubber rock and tree concealments for Reconyx cameras. Rugged, durable and made to fit easily over your 950 & 750 cellular, XR6 or XS8 cameras.



Reconyx Security Enclosures

- Custom fit security enclosures
- Conceals and protects cameras
- Locks included with some models



PB-20™, PB-40™ and PB-180® Power Systems



SSG's rugged, long-lasting PB power systems are designed to work with all SSG video equipment, providing operators with a total surveillance solution that includes the power supply. The PB systems can also be used to run almost any device requiring 12V DC power (or with inverter 120V AC).

SSG's innovative power systems have many advantages over other types of batteries. The PB systems are made with the highest quality LiFePO₄ cells which have a significantly longer life span than other battery chemistries. LiFePO₄ is a non-toxic substance making the battery life safer to use, and it is also a more stable chemistry than others and is far less likely to suffer from thermal run away. These portable systems weigh less than other chemistries of the same capacity and the larger models are provided in rolling Pelican case format for quick and easy deployment. The PB systems are built on a stable and controlled platform which includes low voltage cutoff and cell balancing to allow the cells to perform to their full capacity.

The PB systems include an advanced battery monitor that allows users to monitor their battery status. It constantly measures the battery voltage and battery current and uses this information to calculate the actual state of charge of the battery.

The PB-180 also comes with a standard and a ruggedized rapid battery charger. The rapid charger allows operators to recharge the PB-180 in less than 3 hours when needed for back-to-back missions.

*For more information or a price quote:
Email - sales@specialservicesgroup.us
Call - (209) 682-5026*

PB-180® - Pole Mount Power System



SSG's innovative PB-180 Pole Mount power system has many advantages over other types of batteries. The PB-180 Pole Mount is made with the highest quality LiFePO4 cells which have a significantly longer life span than other battery chemistries. LiFePO4 is a non-toxic substance making the battery safer to use, and it is also a more stable chemistry than others and is far less likely to suffer from thermal run away. The PB-180 Pole Mount weighs less than other chemistries of the same capacity and is provided in NEMA box with mounting brackets for quick and easy deployment. The PB-180 Pole Mount is built on a stable and controlled platform which includes low voltage cutoff and cell balancing to allow the cells to perform to their full capacity.

- Quick and easy deployment with single on/off button.
- Safe technology – less likely to catch fire or explode if damaged.
- Half the weight of an equivalent capacity lead acid battery.
- Over 2000 deep discharge cycles vs. 300 for lead acid batteries.
- Approximately double the usable capacity of lead acid batteries.
- High discharge & recharge rate capability.
- Extremely low self-discharge rate unlike lead acid batteries.
- Does not suffer from thermal runaway like Li-Ion or Li-Po.
- Can be safely used with no loss in performance up to 140°F.
- Does not contain any toxic heavy metals like lead & cadmium.
- The most ecofriendly battery chemistry available.

SP-180™ Solar Power System



Note: SP-180 Solar Charge Kit requires separate purchase of PB-180® battery to operate.

SSG's new SP-180 solar system adds high-performance solar electric technology to the SSG line of PB-180 batteries. The SP-180 Solar Kit comes in a ruggedized Pelican case equipped with the conversion components allowing the system to power 12V DC devices such as the PB-180 battery. The SP-180 includes ten lightweight, flexible, folding 120 watt super-efficient solar panels that plug into the Pelican case. The case then plugs into the charging port of the PB-180 battery for operation.

Features of the SP-180 Kit:

- 10 x 120 watt super-efficient and super light, folding portable solar panels.
- 1200 watts of the highest efficiency SunPower solar panels available.
- Panels can be laid flat on the roof or on the ground.
- Lightweight 9-pound panels are very easy to move around vs. heavy glass panels.
- The SunPower 22% efficiency rated solar cells provide the smallest panel footprint possible vs. less efficient solar cells that require more square footage per watt.
- SunPower cells produce 25-35% more power compared to conventional cells and deliver the highest energy per rated watt compared to a conventional panel.
- No light-induced degradation = 2 - 3% more energy.
- Low temperature coefficient = 1 - 2% more energy at 35-40°C ambient temperature.
- Low light and broad spectral response = up to 1% more energy in overcast and low-light conditions.
- Corrosion resistant and crack resistant.
- Eco-Friendly lead-free components are RoHS compliant. Conventional cells often require components with lead.
- Ruggedized Pelican case solar charge controller.
- Digital display monitor.
- Automatic forced air cooling (operates while case is closed).

For more information or a price quote:

Email - sales@specialservicesgroup.us

Call - (209) 682-5026

Ammo Box Batteries



SSG's innovative PB-20™-AB and PB-40™-AB Ammo Box batteries are designed to fulfill a dual role including providing emergency power or outdoor power for field deployed equipment. Typical uses may include powering surveillance equipment, smart devices, radios, search and rescue equipment or many other 12V devices. Both a USB charging port and Anderson (or optional cigarette style) port is included. An optional high-performance solar kit is available with the PB-40-AB for continuous solar charge.

- Quick and easy weather resistant deployment.
- Power cell phones and other smart devices, emergency equipment and surveillance equipment.
- Safe technology – less likely to catch fire or explode if damaged.
- Half the weight of an equivalent capacity lead acid battery.
- Over 2000 deep discharge cycles vs. 300 for lead acid batteries.
- Approximately double the usable capacity of lead acid batteries.
- Virtually flat discharge curve means no “voltage sag.”
- High discharge & recharge rate capability.
- Extremely low self-discharge rate unlike lead acid batteries.
- Does not suffer from thermal runaway like Li-Ion or Li-Po.
- Can be safely used with no loss in performance up to 140°F.
- Absolutely maintenance free for the life of the battery.
- Does not contain any toxic heavy metals like lead & cadmium.
- The most ecofriendly battery chemistry available.

Optional solar kit with SunPower 22% efficiency rated solar cells in a rapid deploy folding case with handle.

C-CAT
CRYSTAL - CLEAR AUDIO TRANSMITTER



© Special Services Group, LLC, 2015

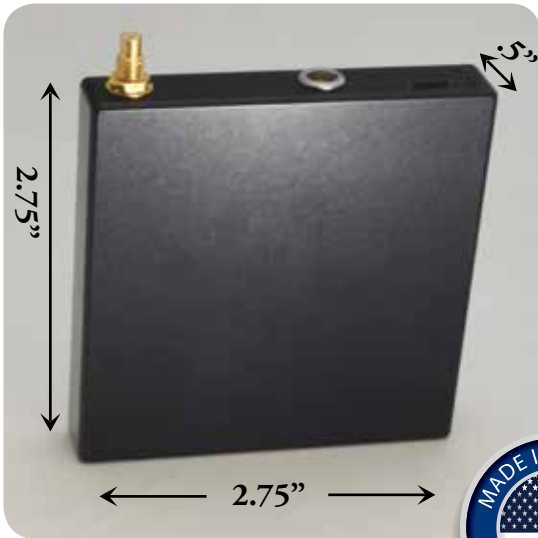

C-CAT® Transmitter and Recorder

- Body wire (audio transmitter) and recorder, pre-programmed and ready-to-go out of the box
- Crystal-clear audio with advanced Digital Signal Processing (DSP)
- Up to 1 Watt output for long-range transmission
- Easy to configure using smartphone/tablet app
- No PC programming, software, or cables to fight
- Records audio to removable MicroSD card (recording feature can be switched off). Records in stereo when the external microphone is plugged in.
- Built-in internal microphone
- External microphone with automatic switch-over to internal mic
- Date and time automatically set from smartphone/tablet (or can be manually set)
- Automatic date and time stamp on recorded audio files

Bantam VHF Radio/Receiver

The Bantam radio receiver is a 16 channel radio receiver that is custom programmed to use with an agency's law enforcement VHF body wire channels. The Bantam is a 5 watt device, which can dramatically increase the distance of body wire reception. The Bantam comes with a 1500 mAh battery and rapid charger, and is fully programmed to an agency's desired frequencies.



A programming cable option

is available for the user to program frequencies independently. Multiple Bantam radios can be used to ensure everyone on the team can hear the operation. Channels can also be reserved for push-to-talk capability amongst the team.

*For more information or a price quote:
Email - sales@specialservicesgroup.us
Call - (209) 682-5026*

i

Our Bantam audio receiver(s) can be paired easily with the C-CAT® audio transmitter. Custom body wire kits housed in Storm/Pelican cases are also available based on customer needs and requirements.

K-MIC™ In-mouth Microphone & Speaker Set

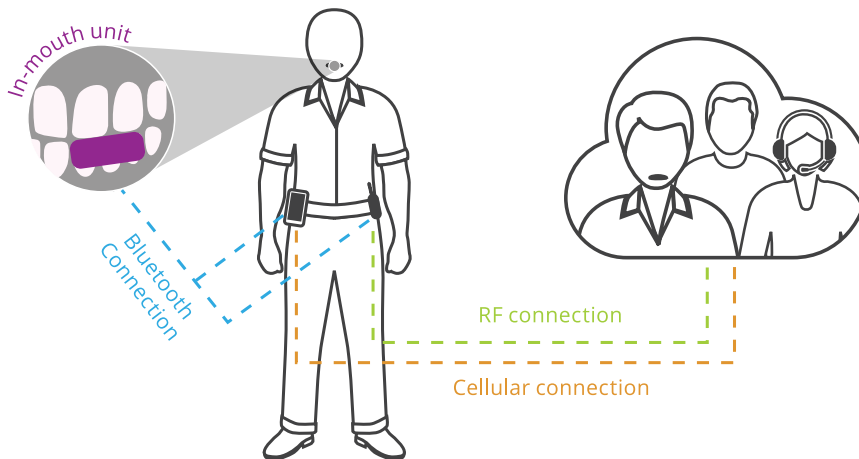
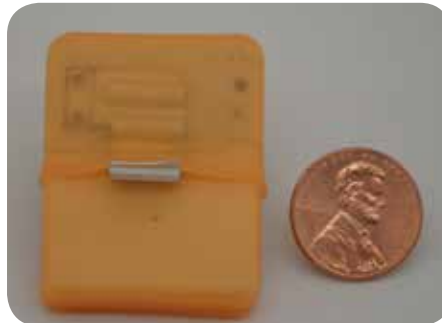

The K-Mic™ is a visually and audibly inconspicuous communications system that allows for real-time audio communication (speaking and hearing) without being noticed.

- Avoid being noticed while using a communications device
- Communicate hands-free in crowded, noisy surroundings

The K-Mic mouthpiece is a small in-mouth microphone & speaker set which connects to your Bluetooth enabled device of choice: Mobile phone, recorder, streamer or K-mic adapter.

The optional K-Mic Adapter is a small Bluetooth enabled receiver which can connect physically to a non-Bluetooth enabled device (two-way radio) via a headphone jack. It can also connect to wireless push-to-talk.

Alternatives	Talking		Hearing	
	Visually inconspicuous: Near-zero visual indications	Audibly inconspicuous: Zero audible indications	Visually inconspicuous: Zero visual indications	Audibly inconspicuous: Zero audible indications
K-Mic	✓	✓	✓	✓
Bluetooth mic w/ mobile phone	✗	✗	✗	✓
PTT RF	✗	✗	✗	✓

CRAB® Keyfob Notification Kit



The SSG Covert Radio Audible Beacon Notification Kit (CRAB®-NK) is an all-in-one kit designed for covert operators to wirelessly send and receive audible alert notifications from a covert keyfob to a handheld radio. The kit includes the CRAB Notification Keyfob transmitter (CRAB-NT-KF) and the CRAB Notification Receiver (CRAB-NR) housed in a ruggedized pelican case.



*For more information or a price quote:
Email - sales@specialservicesgroup.us
Call - (209) 682-5026*

Covert Track[®] Surveillance Cell Phone Application



- Listen to live audio, view live video and GPS tracking from the Covert Track[®] Online Command Center
- App runs covertly in the background from a black screen
- Record video and audio in protected storage for download
- Track device using GPS tracking with cell tower and Wi-Fi triangulation
- Set up to 10 geo-fences with email and text alert system
- Recommended use with Samsung Galaxy phone with option to use your own Android phone
- Track by internet accessible cell phone, laptop or PC
- Record incoming and outgoing phone calls
- Multiple-user accessibility

CV-100™ Tactical Miniature Cellular Audio & Video Surveillance System - All-in-One

Over-The-Horizon Covert Surveillance - From Anywhere to Everywhere



The CV-100 is a complete multi-tool surveillance solution that fits in the palm of your hands. The CV-100 offers video, audio and GPS all over cellular IP. The device allows for connection of multiple tethered cameras, microphones, triggers, and power sources, and provides secure communications.

- Covert surveillance, wearable, fast deployment
- Reliable, small, low power, easy to use
- Modes of Operations:
 - o Online: Live streaming of video, audio, location, events
 - o Autonomous: Event-driven & schedule-driven operation, store & forward
- Smart built-in DVR
- Sensors and I/O capabilities
- Secured communication (4G/LTE, 3G, 2.XG GSM networks)
- Short-range wireless (Wi-Fi, Coded 900MHz, Bluetooth)
- Miniature, portable, robust
- High mission reliability, field proven
- Remote command & control software

CV100™
Tactical Miniature Cellular Video System

- Real-time wireless video, audio, location
- Long range: From anywhere to everywhere
- Usage: Covert surveillance, wearable, fast deployment
- Reliable, small, low power, easy to use

MEMTEX

CV100™ - The Multi-Tool of Technical Operations™
Miniature Tactical Cellular Video System

For more information or a price quote:
Email - sales@specialservicesgroup.us
Call - (209) 682-5026

SuperBat and SuperBat Wireless



The SuperBat device is a rapidly deployable through-the-wall listening system. Available wired or wireless, the SuperBat system allows you to listen to what is happening inside your target surveillance area while reducing unwanted ambient noise.

- Through-the-wall listening.
- Surveillance, SWAT, tactical task forces and container monitoring.
- Super-directional: hear only what is in the target room.
- Stereo signal improves target intelligibility.
- Operates on internal batteries or external power supply.
- Easy to use - simply connect, attach and listen.





Wand II™

The Wand II is a wireless, one-touch, through-the-wall listening device that is rapidly deployable with the push of just one button. The Wand II provides exceptional audio performance while reducing unwanted ambient noise.

- Completely wireless through-the-wall listening.
- One touch, quick deployment, touch, listen and go.
- High sensitivity and gain.
- Advanced noise reduction.

OptiClear™ Pro and OptiClear Pro Wireless

The OptiClear Pro and OptiClear Pro Wireless provide unprecedented audio clarity in the most challenging audio environments. This noise reduction system is excellent for listening to audio in noisy environments such as jails, engine rooms, automobiles, public places and more. No other system today offers the high fidelity, clarity, wireless flexibility and ultra-low power of the OptiClear Pro system.



*For more information or a price quote:
Email - sales@specialservicesgroup.us
Call - (209) 682-5026*

Rapid Infrared Threat Assessment (RITA™)



The Rapid Infrared Threat Assessment (RITA™) device is our newest agent/officer safety device. RITA provides quick identification and location of infrared camera illuminators to help agents maintain a tactical advantage during covert operations. RITA uses sophisticated optical filters to discriminate between visible light and infrared energy. Most modern security cameras have infrared illuminators that are either built-in to the camera or situated close to the camera. RITA causes these infrared sources to appear as if they are blinking, when viewing them through the RITA device on NVGs, so the cameras are easily located. The agent can then plan tactical options to minimize the likelihood of being caught on camera.

U.S. Patent # 9,091,775



RITA works with most common night vision devices but can also be purchased in the complete kits below:

RITA-PVS14 Kit

Includes RITA device, PVS-14 monocular and head mount. An optional smart phone adapter is also available with this kit for video recording to your smartphone.



RITA-GT14 Kit

Includes RITA device and GT-14 monocular. An optional 3x magnifier is also available for this kit.



TailLites™ Infrared Optical Beacons

TailLites™ produce brilliant bursts of infrared light. They may be observed using either night vision equipment or special infrared cameras. A variety of forms are offered that allow vehicles, personnel or assets to be quickly tagged or marked for covert tailing. Unlike GPS based trackers, TailLites™ allow users to see in real time, precisely which item is being tailed.



SkyLite™ - SkyLite™ is a high-power portable IR and visible beacon for law enforcement. SkyLite is a 1.2 x 2.5 inch NIR strobe that is highly visible to NVG, NIR and day-night cameras. Magnets in

the base allow quick and easy deployment. Wide-angle emission provides maximum visibility from all directions. Perfect for identifying and tracking friendlies from the air.

PocketLite™ & PocketLite Advanced™

- Tiny enough to be concealed in a shirt pocket or hat brim, the PocketLite is a brilliant infrared beacon for dismounted use. Shines brightly through pants pocket, shirt pocket or hat band to permit concealment and is highly visible to NVG. Primary uses include tagging of informants or other “friendlies,” tagging of objects such as parcels or marking of roadways or trails. Can also be used to mark strategic spots on structures such as doorways. PocketLite blinks continuously for up to 36 hours. PocketLite Advanced blinks continuously for 3 to 5 days using a CR2032 replaceable battery.



JamLite™ - At 1/8 inch thick, the JamLite™ can be inserted into a variety of gaps between auto body panels and trim pieces. The infrared beacon

shines out through the gap while the device remains concealed. JamLite™ blinks continuously for up to 3 days.

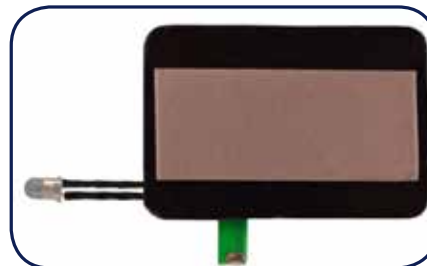
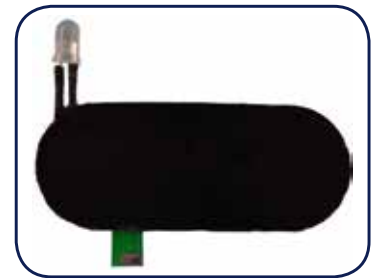

PlateLite™ - PlateLite™ is less than 1/4 inch thick and is easily concealed behind most license

plates using the supplied peel and stick adhesive or “monkey snot.” This product is highly visible to NVG. Extended-life battery permits up to 25 days of continuous beaoning.



*For more information or a price quote:
Email - sales@specialservicesgroup.us
Call - (209) 682-5026*



TagLite™ is attached with the included peel and stick adhesive to allow placement over existing registration tags. While it is undetectable to

the casual observer, its distinctive infrared beacon is easily tracked by the user. TagLite™ will blink continuously for up to 48 hours. Top corners are trimmable to permit installation on plates with overlapping frames.

BulbLite™ is a powerful tool for vehicle tailing and identification. BulbLites™ quickly install in place of a vehicle's standard tail lamps. The taillights still appear red, but now also emit *brilliant* IR flashes. These flashes are highly visible to NVG and IR cameras, while remaining invisible to the naked eye. BulbLite operates whenever the vehicle's running lights are on. BulbLite™ enables the user to positively spot and track vehicles from miles away.



WireLite™ is a wired-in, covert IR beacon. A miniature IR emitter on the end of a thin, flexible 20 foot wire, allows concealed installation in virtually any vehicle. The pulsed IR emissions are visible through NVG and IR cameras. WireLite™ is easily connected to a vehicle's battery or fuse block, providing either full-time beaconing or "ignition on" beaconing.



BrightLite™ Filters are designed to enhance the visibility of TailLites™ products by reducing extraneous light. Available in 6x and 30x improvement in visibility, BrightLite™ Filters are small and are designed to quickly attach to NVG gear. The 6x filter is best for observation in dark environments

and for tracking non-vehicle mounted TailLites™. The 30x filter reduces glare from headlights, vehicle taillights, and urban lighting, thereby highlighting the visual signal from vehicle mounted TailLites™.

CRAB® RF Transmitters

CRAB® RF tracking equipment was designed for remote radio telemetry tracking in an asymmetrical environment. Due to the small size of the CRAB® transmitters, suspects, assets and personnel can be tracked in areas where GPS does not operate. CRAB® transmitters are often used for bait operations, asset tracking, suspect tracking, and personnel tracking and locating. Custom kit options are available based on customer needs and mission requirements.



CRAB® RF Transmitters

- High power RF transmitters
- Various battery configurations
- Miniature size
- Great for asset tracking and bait items

Transmitter Options Include:

- Package Delivery
- Activity
- Standard Pulse
- Mortality
- Asset Protection
- Light Detection
- Mini
- Micro



CRAB® RX RF Receiver

- Long range RF receiver
- Lightweight design
- Easy to use w/CRAB® transmitters
- Great for asset tracking and bait items



© Special Services Group, LLC, 2011

For more information or a price quote:
Email - sales@specialservicesgroup.us
Call - (209) 682-5026

STEALTH III

Covert Track® Stealth III GPS Tracker

- Live GPS CDMA (Verizon) 3G tracker
- **Hard wire version also available**
- Locate anytime ability
- Geo-fence boundaries
- Tamper alerts
- Water resistant design
- 5 second updates
- Secure Covert Track© web-based tracking
- Warrant tracking functionality

**Photo of device available upon request*



Covert Track® MicroTracker IV

- Miniature (2.8" x 1.6" x 1.1")
- Locate NOW ability
- 1.3Ah internal rechargeable battery
- Panic button
- Geo-fence boundaries
- Internal motion sensor
- Secure Covert Track© web-based tracking

Covert Track© HSPA Pro GPS Tracker

- Hard-wire HSPA GSM GPS tracker
- 7 Inputs / 5 Outputs
- Motion Detection
- Ignition on alert
- Warrant tracking functionality
- Live web-based tracking system
- Ideal for bait & fleet tracking
- Easy installation



STEALTH IV

Covert Track© Stealth IV GPS Tracker

- Live GSM HSPA (AT&T) 3G tracker
- Optional RF tracking (receiver not included)
- Bluetooth proximity tracking
- Locate anytime ability
- Geo-fence boundaries
- Tamper alerts
- Water resistant design
- 5 second updates
- Secure Covert Track© web-based tracking
- Warrant tracking functionality

**Photo of device available upon request*

Covert Track® Recon II Tracker

- Live 3G HSPA Quad band modem for worldwide coverage
- 1.7Ah Internal battery
- Compact size (3" x 1.7" x 1.3")
- External Battery Capable
- 2 Inputs & 2 Outputs
- Light & Audio Sensor
- Panic button
- Geo-fence boundaries
- RF & Bluetooth pinger (RF receiver required for RF tracking feature)
- Hardwire Capable



Phantom RFID Exploitation Toolkit

A selection of easy to operate tools that enable a user to exploit common types of 'Radio Frequency Identification' based Access Control Systems (ACS).

RFID technology is often employed as a convenient way in which to implement monitored/controlled access within secured facilities, hotels and offices. The 'Phantom RFID Exploitation Toolkit' is designed to provide an easy method in which to exploit some common types of these systems enabling capabilities such as the following;

- RFID Analyzer – Key to exploiting a system is first knowing what frequency and type of RFID is being employed. This toolkit contains equipment capable of providing this information.
- Cloning of access card/fob to a second physical card
- Electronic emulation of a target card/fob (simulation of target card)
- Privilege escalation of a target card – Enabling access to additional readers within the same facility
- Stay-behind reader logging device with Bluetooth egress – This device is designed to record key information from any access attempts enabling a user to replay this same information on demand via a mobile application and therefor gaining access.



Phantom RFID Exploitation Toolkit (RFID7343)

The 'Phantom RFID Exploitation Toolkit' is designed to exploit some of the more commonly found ACS at present such as 'Mifare Classic 1K, Mifare Classic 4K, HID ProxCard II'. However, future firmware releases can be issued enabling increased functionality and compatibility with additional RFID types helping to ensure longevity of use of this equipment as part of a client's capability and skillset.

Important Note: An understanding of what types of systems this equipment can effectively be deployed against is key to success of this capability. Thus, a 1-day training package is extremely recommended for any users upon purchase.

*For more information or a price quote:
Email - sales@specialservicesgroup.us
Call - (209) 682-5026*

RFID Options

Gecko

The Gecko is capable of monitoring, logging and replaying the communications stream that is sent between an Access Control Systems (ACS) reader and host controller. Communication with the Gecko can be achieved over Bluetooth using Android software.

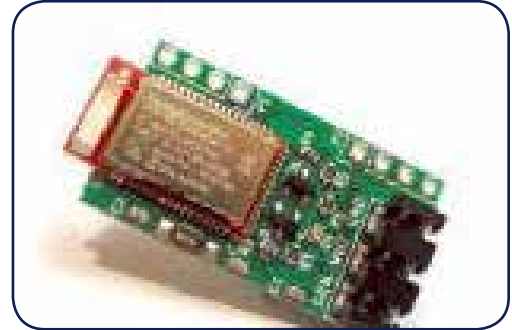

Shadow - Covert Access

Using invisible micro colors and the specialist Shadow solution, Shadow can covertly provide the user with PIN code to an alarm panel. The training required to operate Shadow effectively is minimal, however the results are very powerful.

Shadow can provide the alarm panel PIN for **two** types of alarm panels. Those which require the PIN to be input directly into the keypad (Method 1). Those which require a **control** key to be pressed prior to entering the PIN (Method 2)





Covert Access Equipment

Board Access Kit

Hole & Plug Access Kit

Chipcut

Door Cutter Kit

Hole & Plug Accessory Kit

Gas Abrasive Silent Drill

Gas Abrasive Drill

Covert Audio Installation Equipment

Audio Installation Kit

Vehicle Audio Installation Kit

Long Reach Audio Installation Kit

Tactical Manual Drilling System

Complete Audio Deployment System

Audio Amplifier & Headphones

Drill Spares Pack

Audio Spares Pack

Microphone Spares Pack – Flat Response

Microphone Spares Pack – Roll Off

Covert Video Installation Equipment

Square Camera Cutting Kit

Bullet Camera Long Reach Accessory Kit

Angled Camera Cutter Kit (Bullet)

Reverse Drill Kit For Audio And Video

Angled Camera Cutter Kit – Square FA

Through Wall Camera Kit

Complete Video Deployment System

Video Monitor

Camera Break In Box And Eye Piece Monitor

Spare Camera Kit

Cose ST Installation Kit

Cose DL Installation Kit

Cose FA/AP Installation Kit

Covidence Camera Cutting Kit (All)

Covidence Camera Cutting Kit (Side)

Covidence Camera Cutting Kit (Rear)

ADS Camera Cutting Kit

For more information or a price quote:

Email - sales@specialservicesgroup.us

Call - (209) 682-5026



About Special Services Group, LLC

Special Services Group LLC is a leading supplier of technical solutions for law enforcement, military and government agencies in the United States of America. We are known for our superior products, comprehensive training and excellent customer service. Our headquarters office is located in the heart of the Central Valley of California and we have regional sales directors throughout the US.



SPECIAL SERVICES GROUP

Innovative equipment for people who make the world a safer place.

Surveillance through innovation and imagination.

Criminals constantly change and evolve ...why use equipment that was designed yesterday?

**Special Services Group, LLC
PO Box 825 • Denair CA 95316
Phone: (209) 682-5026 • Fax: (209) 634-4426
E-mail: sales@specialservicesgroup.us
www.specialservicesgroup.us**

From: Greg Mills
Sent: Monday, July 2, 2018 9:34 AM PDT
To: whillyard@ci.irvine.ca.us
Subject: You're Invited to a Lunch and Learn!



[ABOUT](#) [SOLUTIONS](#) [CONTACT](#)

LUNCH 'N LEARN



FACESEARCH™



PLATESEARCH™



BALLISTSEARCH™



PARKING SOLUTIONS

[REGISTER NOW](#)

JULY | **ORANGE COUNTY**
11 | **LUNCH AND LEARN**

Join Vigilant Solutions for a Lunch and Learn on Investigative Technology: Best Practices and Advancements in License Plate Recognition (LPR), Facial Recognition, Ballistics Analysis, and Parking Solutions.

Inv. Dwayne Chappel and Inv. De Anne Wiggington with the Orange County Sheriff's Department invites you to a Lunch and Learn sponsored by Vigilant Solutions. Join us on Wednesday, July 11th from 10:00 AM-2:00 PM at the Orange County Sheriff's Department. Learn how to generate more investigative leads and close more cases with Vigilant's image analysis solutions: license plate recognition (LPR), facial recognition, ballistics analysis and LPR based parking solutions.

Special presenter for this event will be Vigilant's VP of Client Relations and retired Lt. Commander, NYPD, Tom Joyce. Tom and the Vigilant Solutions team will share techniques, policies, and procedures on these key technologies.

Inv. Dwayne Chappel with the Orange County Sheriff's Department will share their recent successes with the use of LPR in their investigations. Learn firsthand how a successful LPR deployment can generate investigative leads for your agency.

This is an open forum where questions and conversation are welcome.

Topics will include:

- Fixed and mobile LPR data and analytic tools to develop investigative leads
- Applications for facial recognition in the investigative process
- Ballistics image capture station for quickly and easily processing cartridge cases at the crime scene
- Leverage LPR cameras and data analytics for parking enforcement and revenue recovery

Lunch will be provided for all attendees.

Cannot attend this Lunch and Learn?

Interested in hosting one at your agency? [Learn More](#)

REGISTER NOW

WHEN

Wed, July 11, 2018 10:00 AM - 2:00 PM PDT

WHERE

Orange County Sheriff's Department

1900 West Katella Ave.

Orange, CA 92867



BE SAFE. BE SMART. BE VIGILANT.

VigilantSolutions.com - 925-398-2079



Vigilant Solutions, 1152 Stealth Street, Livermore, CA 94551, 925-398-2079

[Unsubscribe](#)

From: Greg Mills
Sent: Tuesday, July 10, 2018 6:35 AM PDT
To: whillyard@ci.irvine.ca.us
Subject: It's not too late to register for our Lunch and Learn!



[ABOUT](#) [SOLUTIONS](#) [CONTACT](#)

LUNCH 'N LEARN



FACESEARCH™



PLATESEARCH™



BALLISTCSEARCH™



PARKING SOLUTIONS

[REGISTER NOW](#)

JULY | **ORANGE COUNTY**
11 | **LUNCH AND LEARN**

Join Vigilant Solutions for a Lunch and Learn on Investigative Technology: Best Practices and Advancements in License Plate Recognition (LPR), Facial Recognition, Ballistics Analysis, and Parking Solutions.

Inv. Dwayne Chappel and Inv. De Anne Wiggington with the Orange County Sheriff's Department invites you to a Lunch and Learn sponsored by Vigilant Solutions. Join us on Wednesday, July 11th from 10:00 AM-2:00 PM at the Orange County Sheriff's Department. Learn how to generate more investigative leads and close more cases with Vigilant's image analysis solutions: license plate recognition (LPR), facial recognition, ballistics analysis and LPR based parking solutions.

Special presenter for this event will be Vigilant's VP of Client Relations and retired Lt. Commander, NYPD, Tom Joyce. Tom and the Vigilant Solutions team will share techniques, policies, and procedures on these key technologies.

Inv. Dwayne Chappel with the Orange County Sheriff's Department will share their recent successes with the use of LPR in their investigations. Learn firsthand how a successful LPR deployment can generate investigative leads for your agency.

This is an open forum where questions and conversation are welcome.

Topics will include:

- Fixed and mobile LPR data and analytic tools to develop investigative leads
- Applications for facial recognition in the investigative process
- Ballistics image capture station for quickly and easily processing cartridge cases at the crime scene
- Leverage LPR cameras and data analytics for parking enforcement and revenue recovery

Lunch will be provided for all attendees.

Cannot attend this Lunch and Learn?

Interested in hosting one at your agency? [Learn More](#)

REGISTER NOW

WHEN

Wed, July 11, 2018 10:00 AM - 2:00 PM PDT

WHERE

Orange County Sheriff's Department

1900 West Katella Ave.

Orange, CA 92867



BE SAFE. BE SMART. BE VIGILANT.

VigilantSolutions.com - 925-398-2079



Vigilant Solutions, 1152 Stealth Street, Livermore, CA 94551, 925-398-2079

[Unsubscribe](#)

From: Kim Mohr
Sent: Wednesday, July 11, 2018 6:40 PM PDT
To: Kim Mohr
CC: Mike Hamel; Grace K. Leung
Subject: Council Advisory: Automated License Plate Reader article
Attachments: EFF story FINAL 7-11-18.pdf

Mayor and City Council,

The Irvine Police Department has responded to media inquiries regarding the use of Automated License Plate Readers (ALPR), a technology tool that is common in law enforcement. The inquiries stem from a post on the website of a “watchdog” group called the Electronic Frontier Foundation that suggests the Irvine Company is sharing ALPR data gathered at some of its retail centers with Immigration and Customs Enforcement (ICE). Both the Irvine Company and the vendor that stores the ALPR data have come out with strongly worded statements denying this claim. The article can be seen here: <https://www.eff.org/deeplinks/2018/07/california-shopping-centers-are-spying-ice-contractor>.

The Irvine Company uses mobile Automated License Plate Readers at its retail centers at the Irvine Spectrum and The Marketplace, and at locations in other cities. When the reader “hits” on a license plate in our City that is linked to a crime, IPD Dispatch receives a notification and sends officers to investigate. The Irvine Company does not see this information and is not notified of the hit.

Since the post yesterday, mainstream media outlets have inquired with the Irvine Police Department as to whether we share the data we receive with ICE. We do not share this data with ICE and have responded as such. The Irvine Police Department uses data from Irvine Company ALPRs and those that are installed on five of our patrol cars to help keep our City safe by identifying license plates that are linked to crimes. Our policy on ALPRs is posted on our website: <https://www.cityofirvine.org/irvine-police-department/automated-license-plate-reader-alpr-425>.

A statement from the Irvine Company on this matter can be seen here: <https://www.irvinecompany.com/press-release/irvine-company-statement-regarding-erroneous-report-about-alpr-technology-use/>. Attached for your reference is the press release from Vigilant Solutions, the vendor that gathers the data.

Some media outlets have already published stories on this topic. We anticipate further stories, including a piece by the *Los Angeles Times*.

Kim Mohr | COMMUNICATIONS MANAGER | IRVINE POLICE DEPARTMENT

949-724-7112 (o)  (c) | 1 Civic Center Plaza, Irvine, CA 92606 | kmohr@cityofirvine.org



NEWS RELEASE

EFF: Stop Creating Fake News and Scaring People!

Vigilant Solutions Demands Transparency and Accountability for the Public

EFF Article on Automated License Plate Reader Data and California Malls is Patently False

LIVERMORE, CALIFORNIA – JULY 11, 2018 – The Electronic Frontier Foundation (EFF) posted an [article on its website](#) on July 10, 2018, accusing [Vigilant Solutions](#), a global machine vision and data analytics company, and our customer – Irvine Company – of sharing vehicle location data with Immigration and Customs Enforcement (ICE) so the agency could spy on mall patrons. This accusation is patently false.

The researcher who authored the piece – Dave Maass – never contacted Vigilant Solutions for comment or to verify the accuracy of the inflammatory allegations contained in his article, which has been falsely characterized as a “report”. As a result, most of the article is false, and the parts that are not false – are at best misleading. The remainder of it is opinion based on speculation and designed to scare the public in a self-serving attempt to generate news to promote the EFF.

Vigilant Solutions is calling out the following key points:

- The entire premise of the article is false. Vigilant Solutions and Irvine Company do not share the Automated License Plate Reader (ALPR) data gathered at malls with ICE. As Irvine Company has stated, it is shared with select law enforcement agencies to ensure the security of mall patrons.
- These law enforcement agencies do not have the ability in Vigilant Solutions' system to electronically copy this data or share this data with other persons or agencies, such as ICE.
- The article notes that “The [City of San Pablo](#) put an expansion of its surveillance network on hold”. This statement is misleading and designed to create a false narrative. The City of San Pablo had concerns about the use of ALPR technology by law enforcement, but they invited privacy advocates and Vigilant Solutions in to meet with them to discuss these concerns. Vigilant Solutions met with Council members and the community and provided them with a demonstration of ALPR’s capabilities to protect the public and shared its commitment to simultaneously helping law enforcement ensure public safety without compromising individual privacy. Following the meeting, the San Pablo City Council later voted unanimously to approve the Vigilant Solutions contract and expand their use of ALPR technology.
- The article notes, “Vigilant Solutions shares data with as many as 1,000 law enforcement agencies nationwide.” This is also a false statement. Vigilant Solutions does not share any law enforcement data. The assertion is simply untrue. Law enforcement agencies **own their own ALPR data** and if they choose to share it with other jurisdictions, they can elect to do so – and they can elect not to share the data with agencies, as well.

Vigilant Solutions always has been and will continue to be compliant with all applicable laws in California and throughout the nation that apply to the use of its technologies.

Vigilant Solutions is evaluating potential legal claims against Mr. Mass and the EFF for its false and misleading article, and respectfully requests the EFF retract the article and replace it with a post apologizing to Vigilant Solutions and Irvine Company for perpetuating fake news about the companies.

###

About Vigilant Solutions

Vigilant Solutions' technology helps law enforcement solve crimes faster to keep officers and communities safe. A leader in machine vision and data analytics for the public safety market internationally, Vigilant Solutions provides license plate recognition (LPR), facial recognition and ballistic analysis to deliver intelligence to agencies across the globe. Built for agencies of all sizes, Vigilant Solutions' technology increases investigative efficiency, generates more leads, connects cases, and reduces crimes with advanced analytics, billions of nationwide commercial LPR detections, and a hosted facial recognition gallery. Bring criminals to justice with Vigilant Solutions. Visit www.VigilantSolutions.com.

Media Contact:

Mary Alice Johnson

703.606.2413

maryalice.johnson@vigilantsolutions.com

From: Cellebrite Trials
Sent: Thursday, July 19, 2018 7:07 AM PDT
To: whillyard@cityofirvine.org
Subject: Get started now with your free Analytics Trial

If you have trouble viewing this email, [read the online version](#).

Take advantage of this innovative analytics solution. Click here to begin: [free trial of Cellebrite Analytics](#)



Analyze data in minutes and solve cases quicker with Analytics Desktop

Analytics Desktop delivers powerful tools to correlate, analyze and cross reference large amounts of data quickly.

- Detect critical images and video automatically
- Identify persons of interest quickly with automatic facial recognition and advanced categorization
- Analyze data from multiple devices and different users in a single platform

Law enforcement is faced with the challenge of analyzing more data in less time and with less resources. Learn how UK law enforcement turned to Cellebrite Analytics to solve their cases, [read the article](#).

For a limited time, try Analytics Desktop. Trial ends on September 1, 2018, so don't delay. Get your free trial now.

Start Now



Visit us at www.cellebrite.com

Please ensure that you add Cellebrite to your "safe senders" list to avoid receiving our emails

in your Junk or Spam folders.

To unsubscribe from communications like this click [here](#).

To unsubscribe from future emails or to update your e-mail preferences click [here](#).

Cellebrite | www.cellebrite.com | All rights reserved
7 Campus Drive, Suite 210 | Parsippany, NJ | 07054 | USA

From: P1 Investigations Product Alerts
Sent: Wednesday, August 15, 2018 8:01 AM PDT
To: nsmiley@ci.irvine.ca.us
Subject: Free Webinar: Facial Recognition Workflow with FaceSearch

Having trouble viewing this email? [View it in your browser.](#)



[ABOUT](#) [SOLUTIONS](#) [CONTACT](#)



FACESEARCH™
WEBINAR

WEBINAR: GO WITH THE FLOW

[REGISTER NOW](#)

JOIN US

Webinar-Go With the Flow: The 5 Step Process Behind Every Facial Recognition Search

During Roger's tenure as a lead detective in the New York City Police Department's first dedicated facial recognition unit, he acquired the skills and first-hand experience in best practices for facial recognition in public safety. The success of this unit was driven by establishing a defined workflow which helped develop strong investigative leads and close cases faster.

Join Roger Rodriguez, Director of Client Relations for Vigilant Solutions, as he explains the 5 Steps of the Facial Recognition Investigative

Workflow. See firsthand how agencies nationwide are generating positive results with FaceSearch, Vigilant's facial recognition solution.

Register for our webinar: Go With the Flow, and we will explain why the facial recognition process still needs human involvement.

REGISTER NOW

WHEN

Thursday, September 13th, 2018 | 3:00 PM - 4:00 PM EDT

HOSTS

Roger Rodriguez

Director of Client Relations, Vigilant Solutions

Detective, NYPD (RET.)

REGISTER NOW



BE SAFE. BE SMART. BE VIGILANT.
VigilantSolutions.com • 925-398-2079



Vigilant Solutions, 1152 Stealth Street, Livermore, CA 94551, 925-398-2079

If you do not wish to receive future PoliceOne Product Alerts, please [unsubscribe](#).
To change your email address, update your [profile](#). © 2018: PoliceOne.com. All Rights Reserved.
200 Green Street, 2nd Floor, San Francisco, CA 94111

From: Sam Rabadi
Sent: Tuesday, August 21, 2018 1:34 PM PDT
To: whillyard@cityofirvine.org
Subject: Back to School: Remaining Vigilant to Keep Schools Safe



[ABOUT](#) [SOLUTIONS](#) [CONTACT](#)



BACK TO SCHOOL: REMAINING VIGILANT TO KEEP SCHOOLS SAFE



JOIN US FOR A WEBINAR: TUESDAY, AUGUST 28TH | 3-4PM EST

Dear William,

With the rising number of school shootings over the past couple of years, schools are looking at alternative technology solutions to help bolster security. While there are many resources out there that can potentially bring down the numbers, school officials are struggling with balancing the need to protect their students and teachers and creating an environment that feels welcoming and inherently safe.

Join Sam Rabadi, Retired SAC ATF and Roger Rodriguez, Retired NYPD Detective as they explain how schools can take a multi-pronged approach to ensure public safety by using Vigilant's Safe Campus Solution. This solution combines fixed and mobile deployments of license plate readers (LPR) and facial recognition which can help identify an unknown subject and disrupt or mitigate any threat taking a path towards violence.

Vigilant's Safe Campus Solution will:

- Provide a safer and more secure learning environment
- Increase officer safety
- Assist in deploying proven crime prevention strategies
- Allow you to acquire very cost-efficient services

Register today to see how you can add two additional layers of security to your existing multi-layered comprehensive security platform!

Thanks and stay safe!

REGISTER NOW

WHEN

Tuesday, August 28, 2018 | 3:00 PM - 4:00 PM EST

HOSTS

Sam Rabadi

Director, Business Development, Vigilant Solutions
Special Agent in Charge, ATF (RET.)

Roger Rodriguez

Director of Client Relations, Vigilant Solutions
NYPD Detective (RET.)

REGISTER NOW



BE SAFE. BE SMART. BE VIGILANT.

VigilantSolutions.com • 925-398-2079



Vigilant Solutions, 1152 Stealth Street, Livermore, CA 94551, 925-398-2079

[Unsubscribe](#)

From: Team Vigilant
Sent: Thursday, August 23, 2018 12:09 PM PDT
To: whillyard@ci.irvine.ca.us
Subject: Introducing the Vigilant Communities Award



[ABOUT](#) [SOLUTIONS](#) [CONTACT](#)

VIGILANT COMMUNITIES AWARD

Introducing the Vigilant Communities Award

We're excited to announce the Vigilant Communities Award, which honors law enforcement agencies who have used LPR, facial recognition, and/or ballistics analysis/firearms mapping technology in an innovative way.

We are currently accepting nominations until September 7, 2018 at 11:59PM PST. Do you think you're the agency we're looking for? Or do you know an agency you'd like to nominate? We want to know! Winners will receive a \$2,000 donation to their fallen officers fund.

[NOMINATE NOW](#)



BE SAFE. BE SMART. BE VIGILANT.

VigilantSolutions.com • 925-398-2079



Vigilant Solutions, 1152 Stealth Street, Livermore, CA 94551, 925-398-2079

[Unsubscribe](#)

From: Sam Rabadi
Sent: Monday, August 27, 2018 8:13 AM PDT
To: whillyard@ci.irvine.ca.us
Subject: There's Still Time to Register for our Webinar: Back to School: Remaining Vigilant to Keep Schools Safe



[ABOUT](#) [SOLUTIONS](#) [CONTACT](#)



BACK TO SCHOOL: REMAINING VIGILANT TO KEEP SCHOOLS SAFE



JOIN US FOR A WEBINAR: TUESDAY, AUGUST 28TH | 3-4PM EST

Dear William,

With the rising number of school shootings over the past couple of years, schools are looking at alternative technology solutions to help bolster security. While there are many resources out there that can potentially bring down the numbers, school officials are struggling with balancing the need to protect their students and teachers and creating an environment that feels welcoming and inherently safe.

Join Sam Rabadi, Retired SAC ATF and Roger Rodriguez, Retired NYPD Detective as they explain how schools can take a multi-pronged approach to ensure public safety by using Vigilant's Safe Campus Solution. This solution combines fixed and mobile deployments of license plate readers (LPR) and facial recognition which can help identify an unknown subject and disrupt or mitigate any threat taking a path towards violence.

Vigilant's Safe Campus Solution will:

- Provide a safer and more secure learning environment
- Increase officer safety
- Assist in deploying proven crime prevention strategies
- Allow you to acquire very cost-efficient services

Register today to see how you can add two additional layers of security to your existing multi-layered comprehensive security platform!

Thanks and stay safe!

[REGISTER NOW](#)

WHEN

Tuesday, August 28, 2018 | 3:00 PM - 4:00 PM EST

HOSTS

Sam Rabadi

Director, Business Development, Vigilant Solutions

Special Agent in Charge, ATF (RET.)

Roger Rodriguez

Director of Client Relations, Vigilant Solutions

NYPD Detective (RET.)

[REGISTER NOW](#)



BE SAFE. BE SMART. BE VIGILANT.

VigilantSolutions.com • 925-398-2079



Vigilant Solutions, 1152 Stealth Street, Livermore, CA 94551, 925-398-2079

[Unsubscribe](#)

From: Team Vigilant
Sent: Monday, August 27, 2018 9:44 AM PDT
To: whillyard@ci.irvine.ca.us
Subject: Are You the Agency We're Looking For?



[ABOUT](#) [SOLUTIONS](#) [CONTACT](#)

VIGILANT COMMUNITIES AWARD

Are You the Agency We're Looking For?

We are currently accepting nominations for our Vigilant Communities Award, which recognizes agencies who are using LPR, facial recognition, ballistics analysis, and/or firearms mapping in an innovative way.

Nominations are currently open until September 7, 2018 at 11:59PM PST. You may nominate your agency or someone else. Winners will receive a \$2,000 donation to their fallen officers fund.

Nominate your agency today!

[LEARN MORE](#)



BE SAFE. BE SMART. BE VIGILANT.

VigilantSolutions.com • 925-398-2079



Vigilant Solutions, 1152 Stealth Street, Livermore, CA 94551, 925-398-2079

[Unsubscribe](#)

From: Roger Rodriguez
Sent: Thursday, August 30, 2018 8:31 AM PDT
To: whillyard@cityofirvine.org
Subject: Go With the Flow: The 5 Step Process Behind Every Facial Recognition Search



[ABOUT](#) [SOLUTIONS](#) [CONTACT](#)



FACESEARCH™
WEBINAR

GO WITH THE FLOW

[REGISTER NOW](#)

THE 5 STEP PROCESS BEHIND EVERY FACIAL RECOGNITION SEARCH

In the past year, facial recognition use by public safety has seen significant improvements in matching accuracy. Although the confidence level in the technology is rising, there are still many best practices they are missing out on such as human involvement, a critical deciding factor of whether returned leads are viable or not.

Join Director of Client Relations for Vigilant Solutions and Retired NYPD Detective, Roger Rodriguez as he explains the 5 Steps of the Facial Recognition Investigative Workflow. See firsthand how agencies nationwide are generating positive results with FaceSearch, Vigilant's facial

recognition solution.

During Roger's tenure as a lead detective in the New York City Police Department's first dedicated facial recognition unit, he acquired the skills and first-hand experience in best practices for facial recognition in public safety. The success of this unit was driven by establishing a defined workflow which helped develop strong investigative leads and close cases faster.

[REGISTER NOW](#)

WHEN

Thursday, September 13, 2018 | 3:00 PM - 4:00 PM EDT

HOST

Roger Rodriguez

Director of Client Relations, Vigilant Solutions

Detective, NYPD (RET.)

[REGISTER NOW](#)



BE SAFE. BE SMART. BE VIGILANT.

VigilantSolutions.com | 925-398-2079



Vigilant Solutions, 1152 Stealth Street, Livermore, CA 94551, 925-398-2079

email preference center

From: Team Vigilant
Sent: Monday, September 3, 2018 9:45 AM PDT
To: whillyard@cityofirvine.org
Subject: Nominate Your Agency Today!



[ABOUT](#) [SOLUTIONS](#) [CONTACT](#)

VIGILANT COMMUNITIES AWARD

Are You the Agency We're Looking For?

Has your agency been using technology in an innovative way to keep communities safe? We want to know! Nominate yourself for the Vigilant Communities Award, which recognizes agencies who are using LPR, facial recognition, ballistics analysis and/or firearms mapping in an innovative way.

Nominations are currently open until September 7, 2018 at 11:59PM PST. You may nominate your agency or someone else. Winners will receive a \$2,000 donation to their fallen officers fund.

Nominate your agency today!

[LEARN MORE](#)



BE SAFE. BE SMART. BE VIGILANT.

VigilantSolutions.com • 925-398-2079



Vigilant Solutions, 1152 Stealth Street, Livermore, CA 94551, 925-398-2079

[Unsubscribe](#)

From: Roger Rodriguez
Sent: Tuesday, September 4, 2018 8:22 AM PDT
To: whillyard@cityofirvine.org
Subject: Have you registered yet? Go With the Flow: The 5 Step Process Behind Every Facial Recognition Search



[ABOUT](#) [SOLUTIONS](#) [CONTACT](#)



FACESEARCH™
WEBINAR

GO WITH THE FLOW

[REGISTER NOW](#)

THE 5 STEP PROCESS BEHIND EVERY FACIAL RECOGNITION SEARCH

In the past year, facial recognition use by public safety has seen significant improvements in matching accuracy. Although the confidence level in the technology is rising, there are still many best practices they are missing out on such as human involvement, a critical deciding factor of whether returned leads are viable or not.

Join Director of Client Relations for Vigilant Solutions and Retired NYPD Detective, Roger Rodriguez as he explains the 5 Steps of the Facial Recognition Investigative Workflow. See firsthand how agencies nationwide are generating positive results with FaceSearch, Vigilant's facial

recognition solution.

During Roger's tenure as a lead detective in the New York City Police Department's first dedicated facial recognition unit, he acquired the skills and first-hand experience in best practices for facial recognition in public safety. The success of this unit was driven by establishing a defined workflow which helped develop strong investigative leads and close cases faster.

[REGISTER NOW](#)

WHEN

Thursday, September 13, 2018 | 3:00 PM - 4:00 PM EDT

HOST

Roger Rodriguez

Director of Client Relations, Vigilant Solutions

Detective, NYPD (RET.)

[REGISTER NOW](#)



BE SAFE. BE SMART. BE VIGILANT.

VigilantSolutions.com | 925-398-2079



Vigilant Solutions, 1152 Stealth Street, Livermore, CA 94551, 925-398-2079

email preference center

From: Roger Rodriguez
Sent: Tuesday, September 11, 2018 8:28 AM PDT
To: whillyard@cityofirvine.org
Subject: There's still time to register for our webinar -
Go With the Flow: The 5 Step Process Behind Every Facial Recognition Search



[ABOUT](#) [SOLUTIONS](#) [CONTACT](#)



FACESEARCH™
WEBINAR

GO WITH THE FLOW

[REGISTER NOW](#)

THE 5 STEP PROCESS BEHIND EVERY FACIAL RECOGNITION SEARCH

In the past year, facial recognition use by public safety has seen significant improvements in matching accuracy. Although the confidence level in the technology is rising, there are still many best practices they are missing out on such as human involvement, a critical deciding factor of whether returned leads are viable or not.

Join Director of Client Relations for Vigilant Solutions and Retired NYPD Detective, Roger Rodriguez as he explains the 5 Steps of the Facial

Recognition Investigative Workflow. See firsthand how agencies nationwide are generating positive results with FaceSearch, Vigilant's facial recognition solution.

During Roger's tenure as a lead detective in the New York City Police Department's first dedicated facial recognition unit, he acquired the skills and first-hand experience in best practices for facial recognition in public safety. The success of this unit was driven by establishing a defined workflow which helped develop strong investigative leads and close cases faster.

[REGISTER NOW](#)

WHEN

Thursday, September 13, 2018 | 3:00 PM - 4:00 PM EDT

HOST

Roger Rodriguez

Director of Client Relations, Vigilant Solutions

Detective, NYPD (RET.)

[REGISTER NOW](#)



BE SAFE. BE SMART. BE VIGILANT.

VigilantSolutions.com | 925-398-2079



Vigilant Solutions, 1152 Stealth Street, Livermore, CA 94551, 925-398-2079

email preference center

From: Team Vigilant
Sent: Thursday, September 20, 2018 8:08 AM PDT
To: whillyard@ci.irvine.ca.us
Subject: Be Vigilant, Be Happy!



[ABOUT](#) [SOLUTIONS](#) [CONTACT](#)



Join us for Happy Hour at IACP 2018 in Orlando, FL!

We will be hosting happy hours on both Sunday, October 7th and Monday, October 8th. Drop by our booth to grab a drink and some food, and also learn more about license plate recognition, facial recognition, ballistics analysis, gun crime mapping, and some of our new product offerings!

Where: Vigilant's Booth #1139

When: Sunday, October 7th and Monday, October 8th at 1500-1630hrs

What: Cold drinks, yummy food and good company



BE SAFE. BE SMART. BE VIGILANT.

VigilantSolutions.com • 925-398-2079



Vigilant Solutions, 1152 Stealth Street, Livermore, CA 94551, 925-398-2079

[Unsubscribe](#)

From: Vigilant Solutions
Sent: Thursday, October 4, 2018 5:10 AM PDT
To: whillyard@ci.irvine.ca.us
Subject: Vigilant Solutions Acquires Edesix, Ltd.



[ABOUT](#) [SOLUTIONS](#) [CONTACT](#)



INTRODUCING **VIDEOBADGE™ & VIDEOMANAGER™**

BODY WORN CAMERAS AND VIDEO EVIDENCE MANAGEMENT SYSTEM



VIGILANT SOLUTIONS ACQUIRES EDESIX, LTD.

Dear William,

We are very excited to [announce today](#) that Vigilant Solutions has acquired Edesix Ltd, the number one manufacturer of body-worn cameras in the United Kingdom.

Founded in Edinburgh in 2002, Edesix has a global footprint of customers across industries ranging from law enforcement and airline security to fire safety, rail safety, university security and healthcare. Its body worn video system – [VideoBadge™](#) – employs footage encryption and a wire-free design that make it extremely versatile for various types of users and applications.

Similarly, its [VideoManager™](#) software solutions enable web-based viewing and editing of incidents and preparation of evidence packages. The software is designed to control and manage cameras, their footage and footage from other sources in a highly efficient and secure manner. Additionally, its in-car cameras will seamlessly integrate with our suite of technologies.

So, what does this mean for you, our customers?

1. Anyone who works with Vigilant Solutions knows that we are passionate about the fact that our solutions help to keep communities and law enforcement safe. And, by providing you with body worn cameras, we are able to achieve both goals by aiding you in promoting transparency in your engagements with the public.
2. You no longer need to keep your automated license plate recognition, facial recognition, ballistics analysis, gun crime mapping and body worn/in-car camera images siloed in multiple systems. All the images you capture can easily be integrated into our investigative platform, so we can provide you with a single platform for securely managing your images all in one place.
3. There is a new player in the body worn camera market. And, that means increased competition for your law enforcement dollars, which translates to competitive pricing and continued innovation in technology development.

If you are interested in learning more about our body worn camera and video management solutions, please reach out to your Account Manager or contact us at Sales@VigilantSolutions.com.

Be Safe. Be Smart. Be Vigilant.

Shawn Smith

Founder and President, Vigilant Solutions

What new products are you most looking forward to learning more about? **We want to hear from you!** Complete this [two question survey](#) and let us know!



BE SAFE. BE SMART. BE VIGILANT.

VigilantSolutions.com • 925-398-2079



Vigilant Solutions, 1152 Stealth Street, Livermore, CA 94551, 925-398-2079

From: Team Vigilant
Sent: Sunday, October 7, 2018 11:32 AM PDT
To: whillyard@cityofirvine.org
Subject: Meet VIC!



[ABOUT](#) [SOLUTIONS](#) [CONTACT](#)



Meet VIC, the Vigilant Investigative Center™.

VIC, an AI-driven investigative platform, aims to help law enforcement generate leads, accelerate investigations and ultimately help solve crimes and keep communities safe.

Through VIC, you can access our facial recognition, license plate recognition, ballistics analysis, crime mapping and video evidence management technologies in one place.

It's time to talk to VIC.

[Request a Demo!](#)



BE SAFE. BE SMART. BE VIGILANT.

VigilantSolutions.com • 925-398-2079



Vigilant Solutions, 1152 Stealth Street, Livermore, CA 94551, 925-398-2079

From: Team Vigilant
Sent: Friday, October 19, 2018 10:42 AM PDT
To: whillyard@ci.irvine.ca.us
Subject: Come Meet VIC!



[ABOUT](#) [SOLUTIONS](#) [CONTACT](#)



Did you know that you can access all of our solutions from one platform? Vigilant Investigative Center (VIC) is an investigative platform that houses all of our solutions – ALPR, facial recognition, ballistics analysis, gun crime mapping and more – in one place.

Interested in learning more about VIC? Join us for our webinar, Come Meet VIC, hosted by retired NYPD Lieutenant Commander, Tom Joyce. See firsthand how VIC can take your investigations to another level!

DATE: Thurs, November 8th

TIME: 1500 - 1600 EDT

Save a Seat



BE SAFE. BE SMART. BE VIGILANT.

VigilantSolutions.com • 925-398-2079



Vigilant Solutions, 1152 Stealth Street, Livermore, CA 94551, 925-398-2079

From: P1 Investigations Product Alerts
Sent: Tuesday, November 6, 2018 6:00 AM PST
To: nsmiley@ci.irvine.ca.us
Subject: Webinar: Come meet VIC!

Having trouble viewing this email? [View in browser.](#)



[ABOUT](#) [SOLUTIONS](#) [CONTACT](#)



Did you know that you can access all of our solutions from one platform? Vigilant Investigative Center (VIC) is an investigative platform that houses all of our solutions – ALPR, facial recognition, ballistics analysis, gun crime mapping and more – in one place.

Interested in learning more about VIC? Join us for our webinar, Come Meet VIC, hosted by retired NYPD Lieutenant Commander, Tom Joyce. See firsthand how VIC can take your investigations to another level!

DATE: Thurs, November 8th

TIME: 1500 - 1600 EDT

Save a Seat



BE SAFE. BE SMART. BE VIGILANT.
VigilantSolutions.com • 925-398-2079



Vigilant Solutions, 1152 Stealth Street, Livermore, CA 94551, 925-398-2079

If you do not wish to receive future PoliceOne Product Alerts, please [unsubscribe](#).
To change your email address, update your [profile](#). © 2018: PoliceOne.com. All Rights Reserved.
200 Green Street, 2nd Floor, San Francisco, CA 94111

From: Team Vigilant
Sent: Wednesday, November 7, 2018 7:58 AM PST
To: whillyard@ci.irvine.ca.us
Subject: Come Meet VIC!



[ABOUT](#) [SOLUTIONS](#) [CONTACT](#)



Did you know that you can access all of our solutions from one platform? Vigilant Investigative Center (VIC) is an investigative platform that houses all of our solutions – ALPR, facial recognition, ballistics analysis, gun crime mapping and more – in one place.

Interested in learning more about VIC? Join us for our webinar, Come Meet VIC, hosted by retired NYPD Lieutenant Commander, Tom Joyce. See firsthand how VIC can take your investigations to another level!

DATE: Thurs, November 8th

TIME: 1500 - 1600 EDT

Save a Seat



BE SAFE. BE SMART. BE VIGILANT.

VigilantSolutions.com • 925-398-2079



Vigilant Solutions, 1152 Stealth Street, Livermore, CA 94551, 925-398-2079

From: Gerald Becker
Sent: Tuesday, November 27, 2018 2:54 PM PST
To: Michael Moore; Chris Bees; William Hillyard; Kaitlyn Alaimo; Steve Meyer; Shaheen Jahangard; Tom Goodbrand; Jason Nigro; Daniel Hall; Mark Andreozzi; Dave Klug
Subject: FW: Invitation: Face Recognition meeting @ Tue Dec 11, 2018 10am - 11am (PST) (phurtado@cityofirvine.org)
Attachments: invite.ics

All,
This rep is going to show is his facial recognition software. A few of us met him at a recent event and it looks intriguing.
Feel free to join if you are interested.

Thanks,

-----Original Appointment-----

From: Gerald Becker <gerald.becker@n3n.io>
Sent: Thursday, November 22, 2018 11:23 AM
To: Gerald Becker; Pat Hurtado
Subject: Invitation: Face Recognition meeting @ Tue Dec 11, 2018 10am - 11am (PST) (phurtado@cityofirvine.org)
When: Tuesday, December 11, 2018 10:00 AM-11:00 AM (UTC-08:00) Pacific Time (US & Canada).
Where: Irvine Police Department, 1 Civic Center Plaza, Irvine, CA 92606, USA

[more details »](#)

Face Recognition meeting

When Tue Dec 11, 2018 10am – 11am Pacific Time - Los Angeles
Where Irvine Police Department, 1 Civic Center Plaza, Irvine, CA 92606, USA ([map](#))
Joining info meet.google.com/zjx-cnje-wdo
Or dial: +1 315-504-5146 PIN: 640442824#
Calendar phurtado@cityofirvine.org
Who

- Gerald Becker - organizer
- phurtado@cityofirvine.org

Going (phurtado@cityofirvine.org)? [Yes](#) - [Maybe](#) - [No](#) [more options »](#)

Invitation from [Google Calendar](#)

You are receiving this courtesy email at the account phurtado@cityofirvine.org because you are an attendee of this event.

To stop receiving future updates for this event, decline this event. Alternatively you can sign up for a Google account at <https://www.google.com/calendar/> and control your notification settings for your entire calendar.

Forwarding this invitation could allow any recipient to modify your RSVP response. [Learn More](#).

CONFIDENTIAL! This email and any files transmitted with it are confidential and intended solely for the use of the individual or entity to whom they are addressed. If you have received this email in error please notify the system manager. This message contains confidential information and is intended only for the individual named. If you are

not the named addressee you should not disseminate, distribute or copy this e-mail. Please notify the sender immediately by e-mail if you have received this e-mail by mistake and delete this e-mail from your system. If you are not the intended recipient you are notified that disclosing, copying, distributing or taking any action in reliance on the contents of this information is strictly prohibited.

From: Pat Hurtado
Sent: Friday, November 30, 2018 9:03 AM PST
To: William Hillyard
Subject: RE:
Attachments: image001.png

Sweet. Oh, I should preface by saying it is only reference technology stuff. No drama 😊
Brief cam and Facial recognition stuff.

PATRICK HURTADO | LIEUTENANT
Specialized Investigations
City of Irvine | Police Department
phurtado@cityofirvine.org
P. 949.724.7016
1 Civic Center Plaza Irvine , CA 92623



From: William Hillyard
Sent: Friday, November 30, 2018 9:01 AM
To: Pat Hurtado <phurtado@cityofirvine.org>
Subject: Re:

Absolutely. I'll be 10-19 in an hour.

Sent from my iPhone

On Nov 30, 2018, at 8:59 AM, Pat Hurtado <phurtado@cityofirvine.org> wrote:

Are you guys able to meet today before 1200?

PATRICK HURTADO | LIEUTENANT
Specialized Investigations
City of Irvine | Police Department
phurtado@cityofirvine.org
P. 949.724.7016
1 Civic Center Plaza Irvine , CA 92623

<image001.png>

From: William Hillyard
Sent: Wednesday, December 5, 2018 1:45 PM PST
To: Chris Bees
Subject: Tech Spot
Attachments: Cell Phone and Technology Specialist.docx



William Hillyard | Detective | Irvine Police Department
949-724-7085 | 1 Civic Center Plaza, Irvine, CA 92606
whillyard@cityofirvine.org | cityofirvine.org

Cell Phone and Technology Specialist

Goal: to create a position within the investigation bureau or SIU that would be responsible for use, maintenance, and training of existing technology within the Irvine Police Department and the identification, acquisition and application of new and emerging technologies. It would be primarily responsible for the following areas:

Cell phone forensics – Cellebrite, Susteen, and Blacklight

Assist with high voltage installation of Pole Cameras

Covert Cameras

GPS Vehicle Trackers and Parcel

Drones

Review of Video Evidence and assist in the use and implementation of video review and facial recognition software.

Cell Phone Forensics:

Conduct forensic examinations on cellular devices and other portable electronic devices and storage media in an effort to locate and identify evidence related to on-going investigations. Generate reports from the data extracted during these forensic examinations and provide this information to investigators and case agents. Maintain proficiency with the various forensic tools utilized in the Irvine Police Department Cell Phone Forensic Lab. Monitor and update the various forensic software versions utilized for examinations.

Pole Camera Installation:

Conduct installation of the departments pole mounted surveillance camera on power poles and light poles. Given that some of these installations occur in a high voltage environment the applicant will need to attend NATIA's high voltage installation school.

Covert Cameras:

Conduct installations and deployments of the departments cellular and wi-fi based pinhole covert cameras. Ensure the cameras, transmitters, and other equipment are charged and ready for deployment as needed. Create custom housing and enclosures for the various covert cameras to allow for quick deployments in a variety of different environments.

GPS Vehicle Trackers:

Maintain the current inventory of Covertrack GPS vehicle trackers and ensure the trackers are consistently charged and maintained for immediate use by investigation personnel. Perform regular routine maintenance and repairs on the tracking devices and well as regular firmware updates. Ensure department personnel are familiar with the use of the tracking device website and phone application.

Parcel Trackers:

Maintain the current inventory of 3SI parcel trackers and assist with the use and deployment of these devices by department personnel. Ensure the devices are charged and ready for deployment.

Drones:

Be proficient in the use and deployment of the departments inventory of Drones. Ensure the departments inventory of drones is properly maintained and the drones and controllers on constantly charged and ready for use and all of the necessary firmware updates are installed.

Video Review Software and Facial Recognition Software:

Assist with the implementation and training of any facial recognition or video review software that is acquired by the department. Maintain proficiency using the software and assist investigators and other members of the department by reviewing video and providing the case agent with information relevant to their investigations.

The applicant will be cross trained in the various technology equipment currently available and being utilized at the department. These people would be trained and available to assist as part of a collateral assignment to assist patrol, swat, motors, and investigations with the use and deployment of these various technology tools.

The applicant would also attend trainings and evaluate new and emerging technologies to expand the capabilities of the investigations bureau and the Irvine Police Department.

The goal would be to increase the capabilities of the department, lower delays in implementing technologies we have. Increase utilization of the various technologies we have already invested in. And lower the long term costs of training new personnel by having a group of people cross trained in the various technology resources in use in the department today. It would also seek to eliminate current technology resources not being utilized due to the trained

personnel leaving or retiring, and allow new personnel who are brought into the collateral assignment to be trained in the various pieces of technology.

It would be figured out in advance of the group being formed the various technology and resources that would fall under the groups area of responsibility.

Work closely with the City's in-house IT group to ensure functionality and address issues with technology resources that aren't working or being used because of issues with our internal network.

The need for the Irvine Police Department to centralize it's technology resources and the training and personnel to properly implement and utilize them on a constant and ongoing basis, and to insulate the Department from interruptions in utilization due to retirements, departures, and changing assignments.

Personnel in the group would be managed by a Sergeant or LT who would handle call outs and assignments in the case of after hours deployments.

From: Pat Hurtado
Sent: Thursday, December 6, 2018 10:33 AM PST
To: Daniel Hall; Jason Nigro; Mark Andreozzi; Shaheen Jahangard; Chris Bees; William Hillyard
Subject: Facial Recognition demo
Attachments: image001.png

Gents,
Too much going on next Tuesday so I cancelled the facial recognition demo. I will reschedule for after the first of the year.

PATRICK HURTADO | LIEUTENANT

Specialized Investigations

City of Irvine | Police Department

phurtado@cityofirvine.org

P. 949.724.7016

1 Civic Center Plaza Irvine , CA 92623



From: William Hillyard
Sent: Friday, January 4, 2019 2:52 PM PST
To: tavery@veritone.com
Subject: Irvine PD
Attachments: image001.png

Tom,

My name is Bill Hillyard I am a Detective at Irvine PD and have been working with Investigations Sergeants Mark Androozzi and Jason Nigro on acquiring some facial recognition software for the department. At your convenience I was wondering if I could talk with you briefly by phone. My direct line is **Privacy**. I have viewed the webinar regarding your software and spoken with Lucy Hernandez at Anaheim PD regarding what their experiences have been, and I know there were already some initial discussions with our Sergeants about getting a pilot program going to test the software and see how it would perform with our internal systems. I would appreciate the opportunity to discuss this with you further and see what we can do on our end to move forward with evaluating your product.

Thank you,



William Hillyard | Detective | Irvine Police Department
949-724-7085 | 1 Civic Center Plaza, Irvine, CA 92606
whillyard@cityofirvine.org | cityofirvine.org

From: Tom Avery
Sent: Friday, January 4, 2019 2:58 PM PST
To: William Hillyard
Subject: Re: Irvine PD
Attachments: image001.png

Hey Bill,

Would love to chat. I'm wide open this coming Tuesday if that works for you.

Tom

From: William Hillyard <whillyard@cityofirvine.org>
Date: Friday, January 4, 2019 at 3:52 PM
To: "tavery@veritone.com" <tavery@veritone.com>
Subject: Irvine PD

Tom,

My name is Bill Hillyard I am a Detective at Irvine PD and have been working with Investigations Sergeants Mark Andreozzi and Jason Nigro on acquiring some facial recognition software for the department. At your convenience I was wondering if I could talk with you briefly by phone. My direct line is Privacy. I have viewed the webinar regarding your software and spoken with Lucy Hernandez at Anaheim PD regarding what their experiences have been, and I know there were already some initial discussions with our Sergeants about getting a pilot program going to test the software and see how it would perform with our internal systems. I would appreciate the opportunity to discuss this with you further and see what we can do on our end to move forward with evaluating your product.

Thank you,



William Hillyard | Detective | Irvine Police Department
949-724-7085 | 1 Civic Center Plaza, Irvine, CA 92606
whillyard@cityofirvine.org | cityofirvine.org

From: William Hillyard
Sent: Friday, January 4, 2019 3:07 PM PST
To: Tom Avery
Subject: RE: Irvine PD
Attachments: image001.png

That would be great. I work 11am-9pm Tuesday to Friday, and this coming Tuesday I'm pretty much available anytime.

Thank you,

Bill

From: Tom Avery [mailto:tavery@veritone.com]
Sent: Friday, January 4, 2019 2:59 PM
To: William Hillyard <whillyard@cityofirvine.org>
Subject: Re: Irvine PD

Hey Bill,

Would love to chat. I'm wide open this coming Tuesday if that works for you.

Tom

From: William Hillyard <whillyard@cityofirvine.org>
Date: Friday, January 4, 2019 at 3:52 PM
To: "tavery@veritone.com" <tavery@veritone.com>
Subject: Irvine PD

Tom,

My name is Bill Hillyard I am a Detective at Irvine PD and have been working with Investigations Sergeants Mark Andreozi and Jason Nigro on acquiring some facial recognition software for the department. At your convenience I was wondering if I could talk with you briefly by phone. My direct line is Privacy I have viewed the webinar regarding your software and spoken with Lucy Hernandez at Anaheim PD regarding what their experiences have been, and I know there were already some initial discussions with our Sergeants about getting a pilot program going to test the software and see how it would perform with our internal systems. I would appreciate the opportunity to discuss this with you further and see what we can do on our end to move forward with evaluating your product.

Thank you,



William Hillyard | Detective | Irvine Police Department
949-724-7085 | 1 Civic Center Plaza, Irvine, CA 92606
whillyard@cityofirvine.org | cityofirvine.org

From: Tom Avery
Sent: Friday, January 4, 2019 3:12 PM PST
To: William Hillyard
Subject: Re: Irvine PD
Attachments: image001.png

Calendar invite sent. Talk to you next Tuesday.

Have great weekend,
Tom

From: William Hillyard <whillyard@cityofirvine.org>
Date: Friday, January 4, 2019 at 4:07 PM
To: Tom Avery <tavery@veritone.com>
Subject: RE: Irvine PD

That would be great. I work 11am-9pm Tuesday to Friday, and this coming Tuesday I'm pretty much available anytime.

Thank you,

Bill

From: Tom Avery [<mailto:tavery@veritone.com>]
Sent: Friday, January 4, 2019 2:59 PM
To: William Hillyard <whillyard@cityofirvine.org>
Subject: Re: Irvine PD

Hey Bill,

Would love to chat. I'm wide open this coming Tuesday if that works for you.

Tom

From: William Hillyard <whillyard@cityofirvine.org>
Date: Friday, January 4, 2019 at 3:52 PM
To: "tavery@veritone.com" <tavery@veritone.com>
Subject: Irvine PD

Tom,

My name is Bill Hillyard I am a Detective at Irvine PD and have been working with Investigations Sergeants Mark Androozzi and Jason Nigro on acquiring some facial recognition software for the department. At your convenience I was wondering if I could talk with you briefly by phone. My direct line is Privacy. I have viewed the webinar regarding your software and spoken with Lucy Hernandez at Anaheim PD regarding what their experiences have been, and I know there were already

some initial discussions with our Sergeants about getting a pilot program going to test the software and see how it would perform with our internal systems. I would appreciate the opportunity to discuss this with you further and see what we can do on our end to move forward with evaluating your product.

Thank you,



William Hillyard | Detective | Irvine Police Department
949-724-7085 | 1 Civic Center Plaza, Irvine, CA 92606
whillyard@cityofirvine.org | cityofirvine.org

From: William Hillyard
Sent: Friday, January 4, 2019 3:13 PM PST
To: Tom Avery
Subject: RE: Irvine PD
Attachments: image001.png

Perfect. Thank you. Enjoy your weekend.

From: Tom Avery [mailto:tavery@veritone.com]
Sent: Friday, January 4, 2019 3:13 PM
To: William Hillyard <whillyard@cityofirvine.org>
Subject: Re: Irvine PD

Calendar invite sent. Talk to you next Tuesday.

Have great weekend,
Tom

From: William Hillyard <whillyard@cityofirvine.org>
Date: Friday, January 4, 2019 at 4:07 PM
To: Tom Avery <tavery@veritone.com>
Subject: RE: Irvine PD

That would be great. I work 11am-9pm Tuesday to Friday, and this coming Tuesday I'm pretty much available anytime.

Thank you,

Bill

From: Tom Avery [mailto:tavery@veritone.com]
Sent: Friday, January 4, 2019 2:59 PM
To: William Hillyard <whillyard@cityofirvine.org>
Subject: Re: Irvine PD

Hey Bill,

Would love to chat. I'm wide open this coming Tuesday if that works for you.

Tom

From: William Hillyard <whillyard@cityofirvine.org>
Date: Friday, January 4, 2019 at 3:52 PM
To: "tavery@veritone.com" <tavery@veritone.com>
Subject: Irvine PD

Tom,

My name is Bill Hillyard I am a Detective at Irvine PD and have been working with Investigations Sergeants Mark Andreozzi and Jason Nigro on acquiring some facial recognition software for the department. At your convenience I was wondering if I could talk with you briefly by phone. My direct line is (Privacy) I have viewed the webinar regarding your software and spoken with Lucy Hernandez at Anaheim PD regarding what their experiences have been, and I know there were already some initial discussions with our Sergeants about getting a pilot program going to test the software and see how it would perform with our internal systems. I would appreciate the opportunity to discuss this with you further and see what we can do on our end to move forward with evaluating your product.

Thank you,



William Hillyard | Detective | Irvine Police Department
949-724-7085 | 1 Civic Center Plaza, Irvine, CA 92606
whillyard@cityofirvine.org | cityofirvine.org

From: tavery@veritone.com
Sent: Tuesday, January 8, 2019 4:03 PM PST
To: Mark Anderson; Dave Klug; Jason Nigro; Mark Andreozzi; Daniel Hall; Lorie Velarde; Darcy Jones; Rebecca Woolsey; Shaheen Jahangard; Noelle Smiley
Subject: FW: Updated invitation: Meeting at Irvine PD @ Thu Jan 17, 2019 11am - 12pm (MST) (whillyard@cityofirvine.org)
Attachments: invite.ics, image001.png

Please see the attached calendar appointment for next Thursday, January 17 at 10 am here at Irvine PD in the Investigation Conference Room. If you are able to attend we will be meeting with Tom Avery from Veritone Inc regarding their facial recognition software. Veritone currently has pilot programs in place with Anaheim PD and the Orange County Sheriff's Department which allows their users access to over 1.5 million booking photos for suspect comparisons. Veritone's software has already been used by Anaheim and several other local agencies to solve a number of high profile cases for their agencies. We will be discussing the specifics of implementing a similar pilot program with their software here at Irvine PD.

Thank you,



William Hillyard | Detective | Irvine Police Department
949-724-7085 | 1 Civic Center Plaza, Irvine, CA 92606
whillyard@cityofirvine.org | cityofirvine.org

-----Original Appointment-----

From: tavery@veritone.com <tavery@veritone.com>
Sent: Tuesday, January 08, 2019 12:36 PM
To: tavery@veritone.com; William Hillyard
Subject: Updated invitation: Meeting at Irvine PD @ Thu Jan 17, 2019 11am - 12pm (MST) (whillyard@cityofirvine.org)
When: Thursday, January 17, 2019 10:00 AM-11:00 AM (UTC-08:00) Pacific Time (US & Canada).
Where: 1 Civic Center Plaza, Irvine, CA 92606, USA

This event has been changed.

[more details »](#)

Meeting at Irvine PD

When **Changed:** Thu Jan 17, 2019 11am – 12pm Mountain Time - Denver

Where 1 Civic Center Plaza, Irvine, CA 92606, USA ([map](#))

Calendar whillyard@cityofirvine.org

Who

- tavery@veritone.com - organizer
- whillyard@cityofirvine.org

Go over Identify in person.

Going (whillyard@cityofirvine.org)? **Yes** - **Maybe** - **No** [more options »](#)

Invitation from [Google Calendar](#)

You are receiving this courtesy email at the account whillyard@cityofirvine.org because you are an attendee of this event.

To stop receiving future updates for this event, decline this event. Alternatively you can sign up for a Google account at <https://www.google.com/calendar/> and control your notification settings for your entire calendar.

Forwarding this invitation could allow any recipient to modify your RSVP response. [Learn More](#).

From: William Hillyard
Sent: Friday, January 25, 2019 10:13 AM PST
To: Nick Rycroft
CC: Dave Klug; Mark Anderson
Subject: FW: Data export instructions
Attachments: Preparing Arrest Record Data for Import.pdf, image001.png, image002.png

Nick,

When you have a moment could you take a look at the attached document reference a data export we would need to do to participate in a trial run of some facial recognition software we are evaluating. For the trial period we need to provide Veritone with a data export, if we go live with their software future updates can be accomplished via an automated update system they have in place.

Please call my cell phone at [Privacy] if you have any questions.

Thank you,



William Hillyard | Detective | Irvine Police Department
949-724-7085 | 1 Civic Center Plaza, Irvine, CA 92606
whillyard@cityofirvine.org | cityofirvine.org

From: Tom Avery <tavery@veritone.com>
Sent: Tuesday, January 08, 2019 1:00 PM
To: William Hillyard <whillyard@cityofirvine.org>
Subject: Data export instructions

Bill,

Attached is a set of instructions to pass along to your IT staff to prepare the data for export from ILEADS into Identify for Veritone. Look forward to seeing you next week.

Tom

Tom Avery
Vice President Public Safety
Veritone Government
tavery@veritone.com
[Privacy] cell



Veritone, Inc. 575 Anton Blvd. Suite 100, Costa Mesa CA. 92626
www.veritone.com

Preparing Arrest Record Data for Import

This article details the technical specifications for how Arrest Record data should be formatted for import into Veritone's system. At a minimum, the Arrest Record data should consist of the following items:

1. **Arrest Photos** - Photo of suspect taken at the time of booking
2. **Arrest Metadata** - Booking metadata corresponding to each arrest photo, such as Booking Number, Booking Date, Suspect Number, and other demographic information

Arrest Photo Requirements:

- Front-facing head shot, where the entire face is visible and takes up the majority of the image
- Standard image format such as PNG or JPEG
- Each photo file named uniquely (e.g. by Booking Number) and placed into an "Arrest Photos" folder; for example:

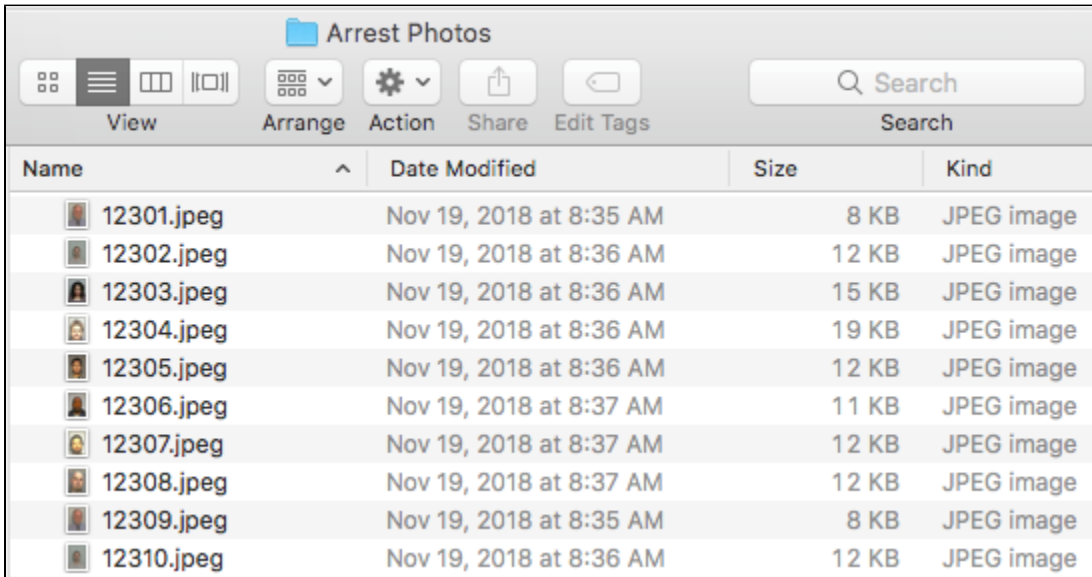

Arrest Metadata Requirements:

- Metadata in CSV (comma-separated values) format, including column headers as the first row
- Each row represents a separate booking record
- Required CSV fields:
 - **Arrest Photo** - Filename of corresponding arrest photo for booking record
 - **Booking Number** - Unique identifier for booking record
 - **Suspect Number** - Unique identifier for suspect (in the case of a repeat offender, the same Suspect Number will be listed multiple times for different Booking Numbers)
- Optional CSV fields:
 - **Booking Date** - Date of booking record ("YYYY-MM-DD" format)
 - Demographic information for suspect, such as:
 - First Name
 - Middle Name
 - Last Name
 - Date of Birth ("YYYY-MM-DD" format)
 - Gender (Male or Female)
 - Height (in inches)
 - Weight (in pounds)
 - Age
 - Race
 - Eye Color
 - Hair Color
 - Known Aliases (if multiple, provide in comma-delimited format)
 - Last Known Address
- Include current date as part of filename for CSV file (e.g. "Arrest Metadata (2018-11-19).csv")

Arrest Photo	Booking Number	Booking Date	Suspect Number	First Name	Middle Name	Last Name	Gender	Date of Birth
12301.jpeg	12301	2018-01-28	1677978921	John	Anderson	Doe	Male	1990-08-14
12302.jpeg	12302	2018-01-28	1677988111	Jane	Graham	Smith	Female	1994-04-01
12303.jpeg	12303	2018-01-28	1678003933	Michael	William	Thomson	Male	1976-10-28

From: Tom Avery
Sent: Wednesday, January 30, 2019 7:15 AM PST
To: William Hillyard
Subject: Veritone pilot agreement
Attachments: Irvine PD Data Sharing Addendum (20190128).docx,
Irvine Police Department License Agreement (IDentify) (20190128).docx,
Master License Terms and Conditions (PS Rev 20180907).pdf, image001.png

Bill,

Attached is the Veritone pilot agreement documents which also include the terms and conditions as well as the data sharing agreement. Let me know if you have any questions.

Thanks,
Tom

Tom Avery
Vice President Public Safety
Veritone Government
tavery@veritone.com
Privacy cell



Veritone, Inc. 575 Anton Blvd. Suite 100, Costa Mesa CA. 92626
www.veritone.com

**Veritone IDentify Application
Data Sharing Addendum**

This Data Sharing Addendum (“Addendum”) is entered into as of February __, 2019, by and between Veritone, Inc. (“Veritone”) and Irvine Police Department (“Licensee”). This Addendum is incorporated by reference into, made a part of and governed by the terms of the License Agreement dated February __, 2019 between Veritone and Licensee (the “Agreement”). In the event of any conflict or inconsistency between the provisions contained in the Agreement and the provisions contained in this Addendum with respect to the subject matter hereof, the provisions of this Addendum shall govern and control. Capitalized terms used but not defined herein shall have the meanings ascribed to them in the Agreement.

1. **IDentify Application.** Veritone has granted to Licensee a right and license to access and use the IDentify Application within the Platform. The IDentify Application allows users to upload booking, arrest and known offender databases (collectively, “Booking Databases”) and use facial recognition technology to compare digital evidence from crime scenes with the Booking Databases to identify potential suspects. The IDentify Application also allows Licensee and other judicial and law enforcement agencies (each, an “Agency”) to elect to share access to their Booking Databases as further described in this Addendum (the “Data Sharing Option”).
2. **Participation in Data Sharing Option.** By executing this Addendum, Licensee hereby elects to participate in the Data Sharing Option, and each of Licensee and Veritone acknowledges and agrees to the supplemental terms and conditions applicable to the Data Sharing Option as set forth in this Addendum, in addition to the terms of the Agreement. All rights granted by each party under this Addendum shall continue during the Term of the Agreement, unless earlier terminated as set forth herein.
3. **Databases.**
 - (a) **Shared Databases.** Licensee will participate in the Data Sharing Option with respect to the Booking Databases indicated below (the option indicated below referred to hereinafter as the “Shared Databases”) (*check/complete one option*):
 - The Booking Databases maintained in the Platform by all other Agencies participating in the Data Sharing Option; or
 - The Booking Databases maintained in the Platform by the following Agencies:
 1. N/A
 - 2.
 - 3.
 - 4.
 - (b) **Access to Licensee Databases.** Licensee hereby grants to Veritone the right to grant access to all Booking Databases that Licensee maintains in the Platform (the “Licensee Databases”) to each other Agency that is participating in the Data Sharing Option and is maintaining a Shared Database in the Platform for use by each such Agency in connection with its use of the IDentify Application, and to other Agencies under limited trial licenses for evaluation purposes.
 - (c) **Access to Shared Databases.** Veritone will make available through the IDentify Application, and hereby grants to Licensee the right to access and use, the Shared Databases.
4. **Termination of Participation.** Licensee may terminate its participation in the Data Sharing Option by providing at least 60 days prior written notice to Veritone (or such shorter period as may be required by a court having jurisdiction). In such event, (i) Veritone will restrict access to the Licensee Databases to Licensee only and will terminate access to the Licensee Databases by any other Agency, and (ii) Veritone will terminate Licensee’s access to all Shared Databases, and Licensee’s use of the IDentify Application thereafter will be limited to use with the Licensee Databases only. Licensee acknowledges that Licensee’s right to access and use the Shared Databases is subject at all times to the participation by other Agencies in the Data Sharing Option on a continuous basis. If any Agency terminates its participation in the Data Sharing Option, Licensee will no longer

have access to the Shared Databases of such Agency or to any information generated from the Shared Databases associated with previously run searches and any resulting matches.

5. **Licensee Responsibilities.** Licensee shall be solely responsible for its use of the Shared Databases. Licensee represents and warrants that (a) it will use the Shared Databases solely in conjunction with its use of the IDentify Application in accordance with the terms of this Addendum, and (b) it will use the Shared Databases (including all data, content, materials, information and results contained in and/or generated from any of the foregoing) in compliance with all applicable laws, statutes, ordinances, rules, regulations, consent decrees, and/or requirements of any regulatory authority. Licensee shall defend, indemnify and hold harmless Veritone and its affiliates and licensors, and their respective members, officers, directors, employees, and agents, from and against any liability, losses, damages, judgments, costs and expenses, including litigation costs and reasonable attorneys' fees, arising out of or resulting from Licensee's use of the Shared Databases or Licensee's breach of any of its representations, warranties or obligations set forth in this Addendum.
6. **Authority.** The person executing this Addendum on behalf of each party represents and warrants that he or she has full authority to execute the same on behalf of such party, and that no other actions or approvals are required for such party to enter into this Addendum and perform its obligations hereunder.

IN WITNESS WHEREOF, the parties have caused this Addendum to be executed by their duly authorized representatives as of the date first above written.

VERITONE, INC.

Signature:

Name:

Title:

IRVINE POLICE DEPARTMENT

Signature:

Name:

Title:



LICENSE AGREEMENT

This License Agreement ("Agreement") is entered into as of the date of the last signature below ("Effective Date") by and between Veritone, Inc. (for itself and/or its subsidiaries), having a principal office located at 575 Anton Boulevard, Suite 100, Costa Mesa, CA 92626 ("Veritone") and the entity listed under Licensee Information below ("Licensee"), with respect to license(s) to Veritone's aiWARE Platform and related Services.

Table with sections: LICENSEE INFORMATION, LICENSE AND SERVICES DETAILS, and TERMS AND CONDITIONS. Includes fields for Agency Name, Address, Contact Info, Term, Users, Fees, and Services.

- 1. Master License Terms and Conditions. This Agreement and Licensee's access to and use of the Platform and Services shall be governed by the Veritone Master License Terms and Conditions attached hereto as Attachment A and incorporated herein by reference (the "Terms and Conditions").
2. Identify Application and Cognitive Processing. During the Term, Veritone will provide Licensee with access to the IDentify Application and the cognitive processing specified above for content uploaded to the Platform by Licensee through the IDentify Application.
3. Limitations. Licensee acknowledges that the IDentify Application is intended to be used by Licensee only as a tool to support review of digital evidence in connection with its investigations, and the IDentify Application and the results generated therefrom should not be considered or relied upon as a substitute for Licensee's customary investigative procedures, protocols and/or requirements.
4. Additional Services. Additional Services, such as on-site training, enhanced onboarding and/or support services, will be made available to Licensee for additional fees, which will be quoted by Veritone upon request.
5. Payment Terms. Veritone will submit an invoice to Licensee on a monthly basis for the License Fees due for the following month, and for any amounts incurred for additional Services performed during the previous month, and such invoices will be due and payable net thirty (30) days following the invoice date.

6. **Term and Termination.** Licensee may elect to terminate this Agreement at the expiration of the Trial Term specified above by providing thirty (30) days prior written notice to Veritone. Unless terminated at the expiration of the Trial Term or as otherwise provided herein, this Agreement will automatically continue following the Trial Term for the Initial Term specified above, and will automatically renew thereafter for successive one-year terms (each renewal term together with the Trial Term and Initial Term, collectively the "Term"). Following the Trial Term, either party may terminate this Agreement at any time, for any reason or no reason, by providing at least sixty (60) days prior written notice to the other party.
7. **Authority.** The person executing this Agreement on behalf of each party represents and warrants that he or she has full authority to execute the same on behalf of such party, and that no other actions or approvals are required for such party to enter into this Agreement and perform its obligations hereunder.

ACCEPTED AND AGREED BY:	
VERITONE, INC.	LICENSEE
Signature:	Signature:
Name:	Name:
Title:	Title:
Date:	Date:

ATTACHMENT A

**VERITONE, INC. MASTER LICENSE TERMS AND CONDITIONS
(PS-Rev 20180907)**

(Attached)

VERITONE, INC.

MASTER LICENSE TERMS AND CONDITIONS

These Master License Terms and Conditions (“Terms and Conditions”) apply to any License Agreement (as defined below) between Veritone, Inc. (or one of its subsidiaries) (“Veritone”) and a licensee (“Licensee”).

- 1. License Agreement; Controlling Terms.** For purposes hereof, “License Agreement” shall mean the written license agreement, or the order form, subscription form, statement of work or other document, including any addenda or exhibits thereto, accepted by Veritone in writing, that evidences the purchase of a license from Veritone by the Licensee (either directly or through an authorized reseller of Veritone) to access and use the Veritone aiWARE Platform (the “Platform”) and associated Services (as defined below). The Platform is an artificial intelligence operating system that delivers near real-time media processing and analytics, enabling users to process, index, organize, manage, search, analyze and share audio, video and other data through a suite of applications and other services (collectively, the “Services”). The specific Services, content, fees and payment terms, number of authorized users, and the term of license shall be as set forth in the License Agreement. The License Agreement may also contain other license-specific terms and conditions. The License Agreement and these Terms and Conditions are collectively referred to herein as this “Agreement.” In the event of any conflict or inconsistency among the terms and conditions set forth in the License Agreement and in these Terms and Conditions, the rights and obligations of the parties shall be interpreted based on the following order of priority: (1) the License Agreement and (2) these Terms and Conditions. This Agreement constitutes the complete and exclusive agreement between the parties with respect to the Platform and Services, superseding and replacing any and all prior agreements, communications, and understandings, both written and oral, regarding such subject matter, and no additional or different provision contained in any purchase order form, order acknowledgment form, invoice or similar form of either party will be effective.
- 2. License, Reservation of Rights, Restrictions.**
 - 2.1. License.** Veritone hereby grants to Licensee, during the Term (as defined in Section 7 below), a non-transferable, non-sublicensable, non-exclusive, revocable license to access and use the Platform and Services, subject to the terms and conditions set forth in this Agreement (the “License”). Licensee agrees to use the Platform and Services only for its internal business purposes in accordance with the terms of this Agreement. For the avoidance of doubt, the Platform and Services and its content may not be displayed publicly; provided that, subject to the provisions of Section 2.4 (Restrictions) and Section 11 (Indemnification) of this Agreement, Licensee may post, publish or otherwise share its owned or licensed content via the Platform for which sharing capabilities are enabled during the Term in accordance with the terms of this Agreement.
 - 2.2. Reservation of Rights.** The Platform and Services are licensed by Veritone to Licensee, and not sold. Licensee acquires only the right to use the Platform and Services in accordance with this Agreement and does not acquire any rights of ownership. Nothing herein shall be construed to transfer any rights, title or ownership of any Veritone or Veritone-licensed software, technology, materials, information or Intellectual Property Rights to Licensee. All right, title and interest (including all Intellectual Property Rights) in and to the Platform and Services shall at all times remain the sole and exclusive property of Veritone and/or its respective licensors and all use thereof shall inure to the benefit of Veritone and/or its respective licensors. Except as expressly set forth in this Agreement, no right or license, express or implied, is granted to Licensee or any third party by estoppel, implication, exhaustion or other doctrine of law, equity or otherwise with respect to any product, service, software, technology, materials, information or Intellectual Property Rights of Veritone or its affiliates or licensors. “**Intellectual Property Rights**” means all forms of proprietary rights, titles, interests, and ownership including patents, patent rights, copyrights, trademarks, trade dresses, trade secrets, know-how, mask works, *droit moral* (moral rights), publicity rights and all similar rights of every type that may exist now or in the future in any jurisdiction, including without limitation all applications and registrations therefore and rights to apply for any of the foregoing.
 - 2.3. Third Party Licenses.** Certain software components of the Platform and Services are supplied pursuant to license agreements from third parties, and Licensee agrees that Licensee’s use of the Platform and Services shall be subject to the provisions of such third party license agreements.
 - 2.4. Restrictions.**
 - 2.4.1. License Restrictions.** Licensee agrees to use the Platform and Services only for lawful purposes and only as expressly authorized under this Agreement. Without limiting the generality of the foregoing, except as expressly authorized hereunder, Licensee agrees that it shall not, directly or indirectly: (i) license, sublicense, sell, resell, rent, lease, transfer, assign, distribute, display or otherwise make the Platform or Services, in whole or in part, including any content or data derived therefrom that is not directly owned by Licensee or for which Licensee has

all necessary rights, available to any third party, or use the Platform or Services to provide services to any third party; (ii) reverse engineer, decompile, disassemble, modify, translate, reconstruct, omit, distort, obscure, copy or create derivative works of all or any portion of the Platform, Services, any underlying software, or any other Veritone Property (as defined below), or otherwise attempt to access the source code of the Platform or Services; (iii) incorporate any portion of the Platform or Services into Licensee's own programs or compile any portion of them in combination with Licensee's own programs; (iv) store or otherwise capture to physical media, or enable a third party to store or capture, the Platform or Services or any portion thereof; (v) permit any persons, other than Licensee's authorized users for which Licensee has procured User IDs pursuant to the License Agreement, to access and use the Platform or Services; (vi) upload or transmit through the Platform or Services any material, content, media or data (collectively, "Licensee Content") with respect to which Licensee does not either own all right, title and interest or have the appropriate license(s) for lawful use, or otherwise violate or infringe upon the intellectual property rights of any third party in Licensee's use of the Platform or Services, including the use or distribution of any data derived from the Platform or Services; or (vii) violate any laws, rules or regulations in connection with its use of the Platform or Services, including any data or content contained in, transmitted through or derived therefrom.

2.4.2. Prohibited Acts. Licensee acknowledges and agrees that Licensee is prohibited from doing any act that may have the effect of undermining the integrity of the Platform, Services, any related computer systems, infrastructure or environment, or the methods by which Veritone provides Services to users. Without limiting the generality of the foregoing, Licensee agrees that it shall not, directly or indirectly: (i) defeat, circumvent or modify any authentication technology or other security measures, controls, limitations, or content or functionality filters contained in or associated with the Platform or Services, or otherwise attempt to access any aspect of the Platform or Services that Licensee has not been granted authorization to access under the License Agreement; (ii) deploy or facilitate the use or deployment of any script, routine, robot, spider, scraper or any other automated means, method or device with respect to Licensee's access and use of the Platform and Services for any purpose, including to access, view, select, or copy in whole or in part, any content, program, functionality of the Platform or Services, or any other proprietary information or trade secret of Veritone that is made available through the Platform or Services; (iii) deploy or facilitate the use or deployment of any program, system, means, method or device, for any purpose that places an unreasonable, unnecessary or excessive demand or load on the Platform, Services, or related hardware and connections, or prohibits, denies or delays access to Services by other users or otherwise threatens the continuous services of Veritone's ISPs, suppliers and vendors; (iv) introduce into the Platform or Services any program, executable file or routine (such as a worm, Trojan horse, cancel-bot, time bomb or virus) irrespective of whether any such program or routine results in detrimental harm to the Platform, Services, or any underlying systems or programs; (v) remove any proprietary notices, labels or marks from the Platform or Services; (vi) establish any direct or deep link or other connection to any specific page or location within the Platform or Services, other than the Platform log-in page; (vii) use or attempt to use another user's account without authorization, or interfere with another user's access to the Platform or Services; or (viii) access or use the Platform or Services to design, develop, build, market or support a competitive product or service.

3. Access and Use. Veritone will enable Licensee to access and use the Platform for the duration of the Term, subject to any early termination of this Agreement in accordance with the terms hereof. Access to the Platform will be through unique log-in credentials assigned to Licensee by Veritone (each, a "User ID"). Licensee shall be given that number of User IDs as specified in the License Agreement. Licensee will provide accurate and complete information in registering its authorized users for account access. Licensee acknowledges and agrees that the log-in credentials assigned hereunder are Confidential Information and may only be used by Licensee and its authorized users to access the Platform in accordance with the terms of this Agreement, and that Licensee will not publish, share, or otherwise enable any third party, directly or indirectly, to access the Platform for any purpose. Licensee further agrees that Licensee is responsible for its and its authorized users' use of the Platform, including use via the User IDs, and for any consequences thereof. Licensee agrees to immediately notify Veritone of any unauthorized or improper use of any log-in credentials of Licensee. All of the rights, obligations, restrictions, representations and warranties related to Licensee's access and use of the Platform under this Agreement shall apply to Licensee and all of Licensee's employees, contractors, consultants, representatives and agents (collectively, "Representatives"). Licensee shall be responsible for all acts and omissions of its Representatives in the performance of this Agreement and for any breach of this Agreement by any of its Representatives.

4. Intellectual Property.

4.1. Veritone Property. As between Veritone and Licensee, Veritone and/or its respective licensors retain all right, title and interest (including Intellectual Property Rights) in and to the Platform and Services, including, but not limited to any

elements, components, content, technology, software, code, documentation, derivative works, revisions, enhancements, modifications, condensations and/or compilations of or relating to the Platform and Services, and any trademarks, brand identifiers, materials and information, which are created, authored, developed, conceived and/or reduced to practice by Veritone and/or its respective licensors, including in connection with Veritone's provision of the Platform and Services to Licensee under this Agreement ("**Veritone Property**").

4.2. Licensee Property. As between Licensee and Veritone, Licensee retains all right, title and interest (including Intellectual Property Rights) in and to the Licensee Content, and any software, technology, trademarks, brand identifiers, materials and information which are independently created, authored, developed, conceived or reduced to practice by Licensee.

5. Licensee Content.

5.1. Content Ownership. Licensee represents and warrants that (i) Licensee and/or its licensors own all right, title and interest in and to all Licensee Content uploaded to or transmitted through the Platform or Services, or otherwise have all rights in such Licensee Content as necessary to use the same in connection with Licensee's use of the Platform and Services, (ii) such Licensee Content does not and will not misappropriate or infringe upon any third party's Intellectual Property Rights, or violate any other rights of any third party, and (iii) Licensee has all rights in such Licensee Content necessary to grant the rights contemplated by this Agreement.

5.2. License to Content. Unless otherwise specified in the License Agreement, Licensee hereby grants to Veritone a non-exclusive, royalty-free, worldwide license (i) to use and display all Licensee Content that Licensee provides to Veritone or that are otherwise uploaded to or captured by the Platform through Licensee's use of the Platform and Services to provide the Services and perform its obligations under this Agreement, directly or through its third party service providers, and (ii) to share such Licensee Content with Veritone's third party service providers solely as required for Veritone's provision of the Platform and Services to Licensee.

5.3. Data Security and Destruction. Veritone will maintain and use adequate administrative, physical, and technical safeguards for protection of the security, confidentiality and integrity of all Licensee Content uploaded to or transmitted through the Platform or Services. Licensee Content shall be used and stored by Veritone solely to the extent required to provide the Services and perform its obligations under this Agreement or as otherwise expressly provided in the License Agreement, and Veritone shall not use or store the Licensee Content for any other purpose whatsoever. Upon termination of this Agreement or upon the written request of Licensee at any time, Veritone shall ensure the secure deletion and destruction of all Licensee Content.

6. Feedback. During the Term, Licensee may provide Veritone with such written evaluations, comments and/or suggestions (collectively, "**Feedback**") regarding the Platform or Services. Licensee acknowledges and agrees that any Feedback provided to Veritone by Licensee hereunder shall be deemed to be Veritone Property and Licensee hereby assigns all right, title and interest in and to such Feedback to Veritone and acknowledges that Veritone will be entitled to, without limitation, implement and exploit any such Feedback in any manner without any restriction or obligation. Notwithstanding the foregoing, Licensee acknowledges that Veritone is not obligated to act on any such Feedback.

7. Term and Termination.

7.1. Term. The term of this Agreement and the License shall be as set forth in the License Agreement (the "**Term**").

7.2. Termination. In addition to any termination rights expressly provided in the License Agreement, this Agreement may be terminated by either party if the other party (i) materially breaches any provision of this Agreement which remains uncured for a period of fourteen (14) days from the date of written notice of such breach; or (ii) makes an assignment for the benefit of its creditors, is declared insolvent, or has a receiver or trustee in bankruptcy appointed to take charge of all or part of such party's property.

7.3. Effect of Termination. If at any time this Agreement is terminated, or upon expiration of the Term, the License and all other rights granted to Licensee herein shall automatically terminate and Licensee shall immediately cease using the Platform and Services.

7.4. Survival. The provisions of Sections 2.2 (Reservation of Rights), 4 (Intellectual Property), 6 (Feedback), 7.3 (Effect of Termination), 8.1 (Fees and Payments), 8.2 (Taxes), 10 (Confidentiality), 11 (Indemnification), 12.2 and 12.3 (Warranty and Disclaimers), 13 (Limitation of Liability), 14 (Miscellaneous) hereof and the payment terms of License Agreement, as applicable, shall survive the expiration or any early termination of this Agreement for any reason.

8. Fees, Charges and Payments.

8.1. Fees and Payments. In consideration for the License and Licensee's access and use of the Platform and Services, Licensee shall pay the license fees, and any applicable additional fees, as set forth in the License Agreement (collectively, the "Fees"). All Fees and other amounts due under this Agreement are payable in U.S. dollars.

8.2. Taxes. All Fees and any other amounts due hereunder are exclusive of taxes and similar assessments which may be imposed on the delivery of the Platform and Services and any other transactions contemplated hereby. Licensee shall be solely responsible for the payment of any and all sales, use, value added, excise, import, or other similar taxes or payments in lieu thereof, including interest and penalties thereon, imposed by any authority, government or governmental agency arising out of or in connection with amounts due hereunder (other than those levied on Veritone's income), and Licensee shall make such payments, and timely file any return or information required by treaty, law, rule or regulation. Upon request, Licensee shall provide Veritone with documentation evidencing such payments. If Veritone is required to pay any such taxes, duties or fees, Licensee shall reimburse Veritone immediately upon receipt of Veritone's invoice thereof.

8.3. Suspension of Platform Access. In addition to Veritone's termination rights set forth herein and without prejudice to any other rights of Veritone at law or in equity, Veritone may suspend its performance under this Agreement and any other agreement with Licensee and Licensee's access to the Platform if Licensee fails to comply with any part of its payment obligations set forth herein. Such suspension of service shall not suspend or otherwise affect Licensee's payment obligations set forth herein.

9. Changes to Platform, Service and Fees. Veritone may, from time to time, in its sole discretion, make changes to the Platform and Services, or a portion thereof including, without limitation, formats, content, reports, functionality, and/or techniques ("Service Change"). In the event of a Service Change, Veritone may, adjust the Fees for the Platform and Services ("Fee Change") in writing. Such Fee Change shall become effective on the date stated in Veritone's notice to Licensee unless, within fifteen (15) days after a Fee Change notice that would result in an increase in the Fees, Licensee notifies Veritone in writing of its refusal to accept the Fee Change, in which event the applicable License to Licensee shall terminate as of the effective date of the change; provided, however, that if the Fee Change is an increase in the Fees, Veritone may, in its sole discretion, elect to rescind the Fee Change, in which case the Platform and Services, as changed, shall continue as provided herein.

10. Confidentiality.

10.1. Confidential Information. Each party (a receiving party) acknowledges and agrees that during the Term and in the course of using the Platform and Services and performing its duties under this Agreement, it may obtain information relating to the other party (a disclosing party), its and/or its customers', vendors', or third party service providers' business or technologies, which is of a confidential and proprietary nature ("**Confidential Information**"). Such Confidential Information may include, but is not limited to, trade secrets, know-how, inventions, techniques, processes, software, algorithms, programs, schematics, data, technology roadmap, sales and marketing plans, and any other information which the receiving party knows or has reason to know is, or which by its nature would reasonably be considered to be, confidential, proprietary or trade secret information of the other party. Without limiting the foregoing, Confidential Information of Veritone shall include the Platform, Services and all associated software and documentation, as well as Feedback or any results of the evaluation or testing of the Platform or Services. The receiving party shall at all times, both during the Term and for a period of three (3) years after its termination (or, in the case of the Platform, Services and any associated software or trade secrets, in perpetuity), keep in trust and confidence all Confidential Information of the disclosing party, and shall not (i) use such Confidential Information other than as expressly authorized under this Agreement or as required for the receiving party to perform its obligations under this Agreement, or (ii) disclose any Confidential Information of the disclosing party to third parties (other than to Veritone's third party service providers in connection with the performance of its obligations under this Agreement), without the disclosing party's prior written consent. The receiving party further agrees to immediately return to the disclosing party or destroy all Confidential Information (including all copies, extracts and summaries thereof) in the receiving party's possession, custody, or control upon the expiration or any termination of this Agreement. The obligations of confidentiality shall not apply to information which (a) has entered the public domain except where such entry is the result of the receiving party's breach of this Agreement; (b) prior to disclosure hereunder, was already in the receiving party's possession and not subject to any confidentiality obligations, as demonstrated by written evidence; (c) subsequent to disclosure hereunder is obtained by the receiving party on a non-confidential basis from a third party who has the right to disclose such information to the receiving party; or (d) has been independently developed by the receiving party without use of or reference to the disclosing party's Confidential Information, as demonstrated by written evidence.

10.2. Permitted Disclosures. The receiving party may make disclosures (i) as required by applicable law or the rules of an stock exchange on which such party's shares are then traded; or (ii) as compelled by court order issued by a court of competent

jurisdiction provided that the receiving party subject to such court order (a) provides the disclosing party with prompt written notice of any such compelled disclosure, (b) uses diligent reasonable efforts to limit disclosure, (c) uses commercially reasonable efforts to obtain confidential treatment or a protective order in connection with the information subject to such compelled disclosure, and (d) allows the disclosing party to participate in any such proceeding.

11. Indemnification.

11.1. Licensee Indemnification of Veritone. Licensee will defend, indemnify and hold harmless Veritone and its subsidiaries, affiliates, successors, assigns, licensors, and their respective members, officers, directors, employees, licensors, agents, from and against any liability or expense, including, without limitation, any expenses, losses, damages, judgments, litigation costs and reasonable attorneys' fees, that Veritone may incur as a result of any claim, suit or proceeding brought against Veritone by any third party arising or resulting from (a) Licensee's breach of any representation, warranty, covenant or obligation contained in this Agreement; or (b) Licensee's use of the Platform or Services (including uploading, using, publishing, posting or otherwise sharing of Licensee's Content or any other data or content derived from the Platform or Services) in any manner that violates this Agreement or any laws, rules, regulations or third party terms and conditions, or that misappropriates or infringes the rights (including Intellectual Property Rights) of any third party; *provided that* Veritone gives Licensee prompt notice of any such claims, cooperates with Licensee in responding to such claims, and permits Licensee to control the defense or settlement of such claims, subject to Veritone's right to (i) conduct the defense of such claims at Veritone's expense, or participate in the defense of such claims with its own counsel at its own expense, and (ii) approve any settlement that binds or purports to bind Veritone.

11.2. Veritone Indemnification of Licensee. Veritone will defend, indemnify and hold harmless Licensee and its subsidiaries, affiliates, successors, assigns, licensors, and their respective members, officers, directors, employees, licensors, agents, from and against any liability or expense, including without limitation, any expenses, losses, damages, judgments, litigation costs and reasonable attorneys' fees that Licensee may incur as a result of any claim, suit or proceeding brought against Licensee by any third party arising or resulting from (a) Veritone's breach of any representation, warranty, covenant or obligation contained in this Agreement; or (b) any allegation that the Platform or Services, or any part thereof, misappropriates or infringes upon any third party's Intellectual Property Rights, except to the extent such claims arise from Licensee's negligence, misconduct or violation of any terms of this Agreement; *provided that* Licensee gives Veritone prompt notice of any such claims, cooperates with Veritone in responding to such claims, and permits Veritone to control the defense or settlement of such claims, subject to Licensee's right to (i) conduct the defense of such claims at Licensee's expense, or participate in the defense of such claims with its own counsel at its own expense, and (ii) approve any settlement that binds or purports to bind Licensee. If the Platform, in whole in part, becomes or, in Veritone's opinion is likely to become, the subject of an infringement claim or action, Veritone may, at its option: (x) procure, at no cost to Licensee, the right for Licensee to continue using the Platform; (y) replace or modify the Platform to render the Platform non-infringing, provided there is no material loss of functionality; or (z) if, in Veritone's reasonable opinion, neither (x) nor (y) above is commercially feasible, terminate this Agreement and refund any prepaid amounts for unused Services during the terminated portion of the Term. The foregoing states Veritone's sole obligation and Licensee's exclusive remedy in the event any such infringement claim or action is commenced or is likely to be commenced.

12. Warranties and Disclaimers.

12.1. Mutual Warranties. Each party represents and warrants to the other that: (i) it is duly organized and validly existing under the laws of the jurisdiction of its incorporation or formation, and has full power, rights and authority to enter into this Agreement and carry out its obligations hereunder; (ii) the person executing this Agreement is authorized to do so on its behalf; (iii) this Agreement is valid and legally binding upon it and (iv) the execution, delivery and performance thereof by such party does not conflict with any other agreement, instrument or understanding to which it is a party or by which it may be bound, nor would violate any applicable law or regulation.

12.2. Disclaimer. THE PLATFORM, SERVICES AND ANY OTHER VERITONE PRODUCTS AND SERVICES ARE PROVIDED ON AN "AS IS" AND "AS AVAILABLE" BASIS. EXCEPT AS EXPRESSLY PROVIDED IN THIS AGREEMENT, VERITONE MAKES NO WARRANTY, EXPRESS OR IMPLIED, WITH RESPECT TO THE PLATFORM AND SERVICES, INCLUDING, WITHOUT LIMITATION, ANY WARRANTY AS TO THE ACCURACY OF PROCESSING RESULTS, ANY WARRANTY OF MERCHANTABILITY, QUALITY OR FITNESS FOR A PARTICULAR PURPOSE, WARRANTIES ARISING FROM COURSE OF DEALING OR USAGE OF TRADE, AND WARRANTIES OF NON-INFRINGEMENT. VERITONE DOES NOT WARRANT THAT THE PLATFORM AND SERVICES ARE ERROR-FREE, WILL RUN UNINTERRUPTED, OR THAT ALL ERRORS CAN OR WILL BE CORRECTED. NO ADVICE OR INFORMATION, WHETHER ORAL OR WRITTEN, OBTAINED BY LICENSEE FROM VERITONE SHALL CREATE ANY SUCH WARRANTY.

12.3. LICENSEE ACKNOWLEDGES AND AGREES THAT THE INTERNET IS A PUBLIC NETWORK OVER WHICH VERITONE EXERTS NO CONTROL. VERITONE MAKES NO REPRESENTATIONS OR WARRANTIES WHATSOEVER, AND SHALL HAVE NO LIABILITY WHATSOEVER, WITH RESPECT TO THE ACCURACY, DEPENDABILITY, PRIVACY, SECURITY, AUTHENTICITY OR COMPLETENESS OF DATA TRANSMITTED OVER OR OBTAINED USING THE INTERNET OUTSIDE OF THOSE SYSTEMS AND NETWORKS CONTROLLED BY VERITONE, OR ANY INTRUSION, VIRUS, DISRUPTION, LOSS OF COMMUNICATION, LOSS OR CORRUPTION OF DATA, OR OTHER ERROR OR EVENT CAUSED OR PERMITTED BY OR INTRODUCED THROUGH LICENSEE'S OWN USE OF THE INTERNET. LICENSEE IS SOLELY RESPONSIBLE FOR IMPLEMENTING ADEQUATE FIREWALL, PASSWORD AND OTHER SECURITY MEASURES TO PROTECT ITS SYSTEMS, DATA AND APPLICATIONS FROM UNWANTED INTRUSION, WHETHER OVER THE INTERNET OR BY OTHER MEANS.

13. Limitation of Liability.

13.1. EXCEPT FOR (A) BREACHES OF EACH PARTY'S OBLIGATIONS UNDER SECTION 10 (CONFIDENTIALITY), AND (B) AMOUNTS FINALLY AWARDED OR SETTLED IN A THIRD PARTY CLAIM FOR WHICH A PARTY IS RESPONSIBLE UNDER SECTION 11 (INDEMNIFICATION), NEITHER PARTY, INCLUDING ITS OFFICERS, DIRECTORS, EMPLOYEES, REPRESENTATIVES AND AFFILIATES, SHALL BE LIABLE FOR ANY INDIRECT, INCIDENTAL, SPECIAL, CONSEQUENTIAL, OR PUNITIVE DAMAGES, INCLUDING WITHOUT LIMITATION, LOST DATA OR LOST PROFITS, OR COSTS OF PROCURING SUBSTITUTE GOODS OR SERVICES, HOWEVER ARISING, EVEN IF IT HAS BEEN ADVISED OF THE POSSIBILITY OF SUCH DAMAGES.

13.2. EXCEPT WITH RESPECT TO EACH PARTY'S CONFIDENTIALITY AND INDEMNIFICATION OBLIGATIONS HEREUNDER, NEITHER PARTY'S LIABILITY FOR DAMAGES ARISING OUT OF, RELATING TO OR IN ANY WAY CONNECTED WITH THIS AGREEMENT SHALL EXCEED THE TOTAL FEES PAID BY LICENSEE TO VERITONE UNDER THIS AGREEMENT.

14. MISCELLANEOUS

14.1. No Assignment. Neither party may assign any of its rights or obligations under this Agreement without the prior written consent of the other party, except that either party may assign its rights and obligations under this Agreement without the consent of the other party to an affiliate directly or indirectly controlling, controlled by, or under direct or indirect common control with such party or in connection with any merger (by operation of law or otherwise), consolidation, reorganization, change in control or sale of all or substantially all of its assets related to this Agreement or similar transaction. This Agreement inures to the benefit of and shall be binding on the parties' permitted assignees, transferees and successors.

14.2. Severability. If any provision of this Agreement is found by a court of competent jurisdiction to be invalid, the parties nevertheless agree that the court should endeavor to give effect to the parties' intentions as reflected in such provision, and the other provisions of this Agreement remain in full force and effect.

14.3. No Waiver. The failure of either party to exercise or enforce any right or provision of this Agreement shall not constitute a waiver of such right or provision.

14.4. Controlling Law. This Agreement shall be governed by and construed in accordance with the laws of the State of California (other than the conflict of law rules) and subject to the sole jurisdiction of the courts sitting in Orange County, California. Notwithstanding the foregoing, nothing in this Section 14.4 shall be deemed to limit the parties' rights to seek injunctive relief in any other court of law of competent jurisdiction.

14.5. Independent Contractors. This Agreement does not create any relationship other than Veritone as an independent contractor performing services covered by this Agreement and Licensee as the party contracting with Veritone for those services. No party is a partner or a legal representative of the other for any purpose whatsoever, nor is any party authorized to make any contract, agreement or warranty on behalf of any other party. Under no circumstance shall one party's employees be construed to be employees of the other party.

14.6. Publicity. Except as required or compelled by applicable law, the rules of any stock exchange, or a court order issued by a court of competent jurisdiction, neither party will make any public statement regarding, or disclose, advertise or publish the terms and conditions of this Agreement without the prior written consent of the other party; provided, however, that Veritone may reference Licensee on Veritone's website, other marketing materials, investor relations materials, and as a customer in Veritone's SEC filings.

14.7. Notices. All notices to either party shall be in writing and delivered by hand or by certified mail or overnight delivery service to the address set forth by Licensee and/or Veritone in the License Agreement, or to such other address as either party shall provide by notice to the other party. Alternatively, the parties may, at their election, utilize email as the method of delivery of any such notice to be provided hereunder. Any such notices sent by email shall be delivered to the email addresses set forth in the License Agreement, or such other email address as designed by a party during the Term. Notices shall be deemed effective when delivered to the applicable address, unless any such notice is sent by

email, in which event, notice shall be deemed effective upon confirmation of delivery by a “read receipt” or other such notice generated by the applicable email system, but in any event, by reply of the recipient of such notice.

- 14.8. Electronic Communication.** In connection with its use of the Platform and Services, Licensee consents to receiving communications from Veritone electronically. Veritone will communicate with Licensee by e-mail or by posting notices on the Platform or through any Services. Licensee agrees that all notices, disclosures and other communications that Veritone provides to Licensee electronically satisfy any legal requirement that such communications be in writing.
- 14.9. Force Majeure.** Except for the obligation to make payments of any Fees or any other amounts due hereunder, neither party will be liable for any failure or delay in its performance under the Agreement due to any cause beyond such party’s control including acts of war, terrorism, acts of God, embargo, riot, sabotage, labor shortage or dispute, governmental act, or failure of the Internet, or any component comprising or operating the network infrastructure thereof (each, a “**Force Majeure Event**”), provided that the delayed party: (i) gives the other party prompt notice of such cause, and (ii) uses its reasonable commercial efforts to promptly correct such failure or delay in performance. If Veritone is unable to provide Service(s) for a period of sixty (60) consecutive days as a result of a continuing Force Majeure Event, either party may elect to terminate this Agreement.
- 14.10. Construction.** This Agreement shall be fairly interpreted and construed in accordance with its terms and without strict interpretation or construction in favor of or against either party. Each party has had the opportunity to consult with counsel in the negotiation of this Agreement.
- 14.11. Counterparts.** This Agreement may be executed in one or more counterparts (including fax or email) each of which shall be deemed an original but all of which taken together shall be deemed one and the same instrument.
- 14.12. Headings.** Unless otherwise expressly stated in this Agreement, the words “herein,” “hereof,” “hereto,” and “hereunder” and other words of similar import refer to this Agreement as a whole and not to any particular section, subsection, or other subdivision. The words “include” and “including” shall not be construed or interpreted as terms of limitation. The words “day,” “month,” and “year” mean, respectively, calendar day, calendar month, and calendar year. Section headings are for reference purposes only, and should not be used in the interpretation hereof.
- 14.13. Amendment.** No addendum, waiver, consent, modification, amendment or change of the terms of this Agreement shall bind either party unless in a writing that references this Agreement and is signed by duly authorized representatives of Licensee and Veritone.
- 14.14. Attorney’s Fees.** If any action arises under this Agreement, including, without limitation the interpretation or enforcement of any term of this Agreement, the prevailing party in any such action shall be entitled to recover its reasonable attorney’s fees and related costs.

From: William Hillyard
Sent: Wednesday, January 30, 2019 9:25 AM PST
To: Dave Klug; Mark Anderson
Subject: Fwd: Veritone pilot agreement
Attachments: image001.png, ATT00001.htm, Irvine PD Data Sharing Addendum (20190128).docx, ATT00002.htm, Irvine Police Department License Agreement (IDentify) (20190128).docx, ATT00003.htm, Master License Terms and Conditions (PS Rev 20180907).pdf, ATT00004.htm, image001.png, ATT00005.htm

Attached are the documents for the pilot program agreement with Veritone. I spoke with Nick Rycroft Monday reference the IT portion of it and he stated when the agreement is signed he would begin working on the data export as requested by Veritone.

Sent from my iPhone

Begin forwarded message:

From: Tom Avery <tavery@veritone.com>
Date: January 30, 2019 at 7:15:09 AM PST
To: William Hillyard <whillyard@cityofirvine.org>
Subject: Veritone pilot agreement

Bill,

Attached is the Veritone pilot agreement documents which also include the terms and conditions as well as the data sharing agreement. Let me know if you have any questions.

Thanks,
Tom

Tom Avery
Vice President Public Safety
Veritone Government
tavery@veritone.com

Privacy [REDACTED] cell

**Veritone IDentify Application
Data Sharing Addendum**

This Data Sharing Addendum (“Addendum”) is entered into as of February __, 2019, by and between Veritone, Inc. (“Veritone”) and Irvine Police Department (“Licensee”). This Addendum is incorporated by reference into, made a part of and governed by the terms of the License Agreement dated February __, 2019 between Veritone and Licensee (the “Agreement”). In the event of any conflict or inconsistency between the provisions contained in the Agreement and the provisions contained in this Addendum with respect to the subject matter hereof, the provisions of this Addendum shall govern and control. Capitalized terms used but not defined herein shall have the meanings ascribed to them in the Agreement.

1. **IDentify Application.** Veritone has granted to Licensee a right and license to access and use the IDentify Application within the Platform. The IDentify Application allows users to upload booking, arrest and known offender databases (collectively, “Booking Databases”) and use facial recognition technology to compare digital evidence from crime scenes with the Booking Databases to identify potential suspects. The IDentify Application also allows Licensee and other judicial and law enforcement agencies (each, an “Agency”) to elect to share access to their Booking Databases as further described in this Addendum (the “Data Sharing Option”).
2. **Participation in Data Sharing Option.** By executing this Addendum, Licensee hereby elects to participate in the Data Sharing Option, and each of Licensee and Veritone acknowledges and agrees to the supplemental terms and conditions applicable to the Data Sharing Option as set forth in this Addendum, in addition to the terms of the Agreement. All rights granted by each party under this Addendum shall continue during the Term of the Agreement, unless earlier terminated as set forth herein.
3. **Databases.**
 - (a) **Shared Databases.** Licensee will participate in the Data Sharing Option with respect to the Booking Databases indicated below (the option indicated below referred to hereinafter as the “Shared Databases”) (*check/complete one option*):
 - The Booking Databases maintained in the Platform by all other Agencies participating in the Data Sharing Option; or
 - The Booking Databases maintained in the Platform by the following Agencies:
 1. N/A
 - 2.
 - 3.
 - 4.
 - (b) **Access to Licensee Databases.** Licensee hereby grants to Veritone the right to grant access to all Booking Databases that Licensee maintains in the Platform (the “Licensee Databases”) to each other Agency that is participating in the Data Sharing Option and is maintaining a Shared Database in the Platform for use by each such Agency in connection with its use of the IDentify Application, and to other Agencies under limited trial licenses for evaluation purposes.
 - (c) **Access to Shared Databases.** Veritone will make available through the IDentify Application, and hereby grants to Licensee the right to access and use, the Shared Databases.
4. **Termination of Participation.** Licensee may terminate its participation in the Data Sharing Option by providing at least 60 days prior written notice to Veritone (or such shorter period as may be required by a court having jurisdiction). In such event, (i) Veritone will restrict access to the Licensee Databases to Licensee only and will terminate access to the Licensee Databases by any other Agency, and (ii) Veritone will terminate Licensee’s access to all Shared Databases, and Licensee’s use of the IDentify Application thereafter will be limited to use with the Licensee Databases only. Licensee acknowledges that Licensee’s right to access and use the Shared Databases is subject at all times to the participation by other Agencies in the Data Sharing Option on a continuous basis. If any Agency terminates its participation in the Data Sharing Option, Licensee will no longer

have access to the Shared Databases of such Agency or to any information generated from the Shared Databases associated with previously run searches and any resulting matches.

5. **Licensee Responsibilities.** Licensee shall be solely responsible for its use of the Shared Databases. Licensee represents and warrants that (a) it will use the Shared Databases solely in conjunction with its use of the IDentify Application in accordance with the terms of this Addendum, and (b) it will use the Shared Databases (including all data, content, materials, information and results contained in and/or generated from any of the foregoing) in compliance with all applicable laws, statutes, ordinances, rules, regulations, consent decrees, and/or requirements of any regulatory authority. Licensee shall defend, indemnify and hold harmless Veritone and its affiliates and licensors, and their respective members, officers, directors, employees, and agents, from and against any liability, losses, damages, judgments, costs and expenses, including litigation costs and reasonable attorneys' fees, arising out of or resulting from Licensee's use of the Shared Databases or Licensee's breach of any of its representations, warranties or obligations set forth in this Addendum.
6. **Authority.** The person executing this Addendum on behalf of each party represents and warrants that he or she has full authority to execute the same on behalf of such party, and that no other actions or approvals are required for such party to enter into this Addendum and perform its obligations hereunder.

IN WITNESS WHEREOF, the parties have caused this Addendum to be executed by their duly authorized representatives as of the date first above written.

VERITONE, INC.

Signature:

Name:

Title:

IRVINE POLICE DEPARTMENT

Signature:

Name:

Title:



LICENSE AGREEMENT

This License Agreement ("Agreement") is entered into as of the date of the last signature below ("Effective Date") by and between Veritone, Inc. (for itself and/or its subsidiaries), having a principal office located at 575 Anton Boulevard, Suite 100, Costa Mesa, CA 92626 ("Veritone") and the entity listed under Licensee Information below ("Licensee"), with respect to license(s) to Veritone's aiWARE Platform and related Services.

Table with sections: LICENSEE INFORMATION, LICENSE AND SERVICES DETAILS, and TERMS AND CONDITIONS. Includes fields for Agency Name, Address, Contact Info, Term, Users, Fees, and Services.

- 1. Master License Terms and Conditions. This Agreement and Licensee's access to and use of the Platform and Services shall be governed by the Veritone Master License Terms and Conditions attached hereto as Attachment A and incorporated herein by reference (the "Terms and Conditions").
2. Identify Application and Cognitive Processing. During the Term, Veritone will provide Licensee with access to the IDentify Application and the cognitive processing specified above for content uploaded to the Platform by Licensee through the IDentify Application.
3. Limitations. Licensee acknowledges that the IDentify Application is intended to be used by Licensee only as a tool to support review of digital evidence in connection with its investigations, and the IDentify Application and the results generated therefrom should not be considered or relied upon as a substitute for Licensee's customary investigative procedures, protocols and/or requirements.
4. Additional Services. Additional Services, such as on-site training, enhanced onboarding and/or support services, will be made available to Licensee for additional fees, which will be quoted by Veritone upon request.
5. Payment Terms. Veritone will submit an invoice to Licensee on a monthly basis for the License Fees due for the following month, and for any amounts incurred for additional Services performed during the previous month, and such invoices will be due and payable net thirty (30) days following the invoice date.

6. **Term and Termination.** Licensee may elect to terminate this Agreement at the expiration of the Trial Term specified above by providing thirty (30) days prior written notice to Veritone. Unless terminated at the expiration of the Trial Term or as otherwise provided herein, this Agreement will automatically continue following the Trial Term for the Initial Term specified above, and will automatically renew thereafter for successive one-year terms (each renewal term together with the Trial Term and Initial Term, collectively the "Term"). Following the Trial Term, either party may terminate this Agreement at any time, for any reason or no reason, by providing at least sixty (60) days prior written notice to the other party.
7. **Authority.** The person executing this Agreement on behalf of each party represents and warrants that he or she has full authority to execute the same on behalf of such party, and that no other actions or approvals are required for such party to enter into this Agreement and perform its obligations hereunder.

ACCEPTED AND AGREED BY:	
VERITONE, INC.	LICENSEE
Signature:	Signature:
Name:	Name:
Title:	Title:
Date:	Date:

ATTACHMENT A

**VERITONE, INC. MASTER LICENSE TERMS AND CONDITIONS
(PS-Rev 20180907)**

(Attached)

VERITONE, INC.

MASTER LICENSE TERMS AND CONDITIONS

These Master License Terms and Conditions (“Terms and Conditions”) apply to any License Agreement (as defined below) between Veritone, Inc. (or one of its subsidiaries) (“Veritone”) and a licensee (“Licensee”).

- 1. License Agreement; Controlling Terms.** For purposes hereof, “License Agreement” shall mean the written license agreement, or the order form, subscription form, statement of work or other document, including any addenda or exhibits thereto, accepted by Veritone in writing, that evidences the purchase of a license from Veritone by the Licensee (either directly or through an authorized reseller of Veritone) to access and use the Veritone aiWARE Platform (the “Platform”) and associated Services (as defined below). The Platform is an artificial intelligence operating system that delivers near real-time media processing and analytics, enabling users to process, index, organize, manage, search, analyze and share audio, video and other data through a suite of applications and other services (collectively, the “Services”). The specific Services, content, fees and payment terms, number of authorized users, and the term of license shall be as set forth in the License Agreement. The License Agreement may also contain other license-specific terms and conditions. The License Agreement and these Terms and Conditions are collectively referred to herein as this “Agreement.” In the event of any conflict or inconsistency among the terms and conditions set forth in the License Agreement and in these Terms and Conditions, the rights and obligations of the parties shall be interpreted based on the following order of priority: (1) the License Agreement and (2) these Terms and Conditions. This Agreement constitutes the complete and exclusive agreement between the parties with respect to the Platform and Services, superseding and replacing any and all prior agreements, communications, and understandings, both written and oral, regarding such subject matter, and no additional or different provision contained in any purchase order form, order acknowledgment form, invoice or similar form of either party will be effective.
- 2. License, Reservation of Rights, Restrictions.**
 - 2.1. License.** Veritone hereby grants to Licensee, during the Term (as defined in Section 7 below), a non-transferable, non-sublicensable, non-exclusive, revocable license to access and use the Platform and Services, subject to the terms and conditions set forth in this Agreement (the “License”). Licensee agrees to use the Platform and Services only for its internal business purposes in accordance with the terms of this Agreement. For the avoidance of doubt, the Platform and Services and its content may not be displayed publicly; provided that, subject to the provisions of Section 2.4 (Restrictions) and Section 11 (Indemnification) of this Agreement, Licensee may post, publish or otherwise share its owned or licensed content via the Platform for which sharing capabilities are enabled during the Term in accordance with the terms of this Agreement.
 - 2.2. Reservation of Rights.** The Platform and Services are licensed by Veritone to Licensee, and not sold. Licensee acquires only the right to use the Platform and Services in accordance with this Agreement and does not acquire any rights of ownership. Nothing herein shall be construed to transfer any rights, title or ownership of any Veritone or Veritone-licensed software, technology, materials, information or Intellectual Property Rights to Licensee. All right, title and interest (including all Intellectual Property Rights) in and to the Platform and Services shall at all times remain the sole and exclusive property of Veritone and/or its respective licensors and all use thereof shall inure to the benefit of Veritone and/or its respective licensors. Except as expressly set forth in this Agreement, no right or license, express or implied, is granted to Licensee or any third party by estoppel, implication, exhaustion or other doctrine of law, equity or otherwise with respect to any product, service, software, technology, materials, information or Intellectual Property Rights of Veritone or its affiliates or licensors. “**Intellectual Property Rights**” means all forms of proprietary rights, titles, interests, and ownership including patents, patent rights, copyrights, trademarks, trade dresses, trade secrets, know-how, mask works, *droit moral* (moral rights), publicity rights and all similar rights of every type that may exist now or in the future in any jurisdiction, including without limitation all applications and registrations therefore and rights to apply for any of the foregoing.
 - 2.3. Third Party Licenses.** Certain software components of the Platform and Services are supplied pursuant to license agreements from third parties, and Licensee agrees that Licensee’s use of the Platform and Services shall be subject to the provisions of such third party license agreements.
 - 2.4. Restrictions.**
 - 2.4.1. License Restrictions.** Licensee agrees to use the Platform and Services only for lawful purposes and only as expressly authorized under this Agreement. Without limiting the generality of the foregoing, except as expressly authorized hereunder, Licensee agrees that it shall not, directly or indirectly: (i) license, sublicense, sell, resell, rent, lease, transfer, assign, distribute, display or otherwise make the Platform or Services, in whole or in part, including any content or data derived therefrom that is not directly owned by Licensee or for which Licensee has

all necessary rights, available to any third party, or use the Platform or Services to provide services to any third party; (ii) reverse engineer, decompile, disassemble, modify, translate, reconstruct, omit, distort, obscure, copy or create derivative works of all or any portion of the Platform, Services, any underlying software, or any other Veritone Property (as defined below), or otherwise attempt to access the source code of the Platform or Services; (iii) incorporate any portion of the Platform or Services into Licensee's own programs or compile any portion of them in combination with Licensee's own programs; (iv) store or otherwise capture to physical media, or enable a third party to store or capture, the Platform or Services or any portion thereof; (v) permit any persons, other than Licensee's authorized users for which Licensee has procured User IDs pursuant to the License Agreement, to access and use the Platform or Services; (vi) upload or transmit through the Platform or Services any material, content, media or data (collectively, "Licensee Content") with respect to which Licensee does not either own all right, title and interest or have the appropriate license(s) for lawful use, or otherwise violate or infringe upon the intellectual property rights of any third party in Licensee's use of the Platform or Services, including the use or distribution of any data derived from the Platform or Services; or (vii) violate any laws, rules or regulations in connection with its use of the Platform or Services, including any data or content contained in, transmitted through or derived therefrom.

2.4.2. Prohibited Acts. Licensee acknowledges and agrees that Licensee is prohibited from doing any act that may have the effect of undermining the integrity of the Platform, Services, any related computer systems, infrastructure or environment, or the methods by which Veritone provides Services to users. Without limiting the generality of the foregoing, Licensee agrees that it shall not, directly or indirectly: (i) defeat, circumvent or modify any authentication technology or other security measures, controls, limitations, or content or functionality filters contained in or associated with the Platform or Services, or otherwise attempt to access any aspect of the Platform or Services that Licensee has not been granted authorization to access under the License Agreement; (ii) deploy or facilitate the use or deployment of any script, routine, robot, spider, scraper or any other automated means, method or device with respect to Licensee's access and use of the Platform and Services for any purpose, including to access, view, select, or copy in whole or in part, any content, program, functionality of the Platform or Services, or any other proprietary information or trade secret of Veritone that is made available through the Platform or Services; (iii) deploy or facilitate the use or deployment of any program, system, means, method or device, for any purpose that places an unreasonable, unnecessary or excessive demand or load on the Platform, Services, or related hardware and connections, or prohibits, denies or delays access to Services by other users or otherwise threatens the continuous services of Veritone's ISPs, suppliers and vendors; (iv) introduce into the Platform or Services any program, executable file or routine (such as a worm, Trojan horse, cancel-bot, time bomb or virus) irrespective of whether any such program or routine results in detrimental harm to the Platform, Services, or any underlying systems or programs; (v) remove any proprietary notices, labels or marks from the Platform or Services; (vi) establish any direct or deep link or other connection to any specific page or location within the Platform or Services, other than the Platform log-in page; (vii) use or attempt to use another user's account without authorization, or interfere with another user's access to the Platform or Services; or (viii) access or use the Platform or Services to design, develop, build, market or support a competitive product or service.

3. Access and Use. Veritone will enable Licensee to access and use the Platform for the duration of the Term, subject to any early termination of this Agreement in accordance with the terms hereof. Access to the Platform will be through unique log-in credentials assigned to Licensee by Veritone (each, a "User ID"). Licensee shall be given that number of User IDs as specified in the License Agreement. Licensee will provide accurate and complete information in registering its authorized users for account access. Licensee acknowledges and agrees that the log-in credentials assigned hereunder are Confidential Information and may only be used by Licensee and its authorized users to access the Platform in accordance with the terms of this Agreement, and that Licensee will not publish, share, or otherwise enable any third party, directly or indirectly, to access the Platform for any purpose. Licensee further agrees that Licensee is responsible for its and its authorized users' use of the Platform, including use via the User IDs, and for any consequences thereof. Licensee agrees to immediately notify Veritone of any unauthorized or improper use of any log-in credentials of Licensee. All of the rights, obligations, restrictions, representations and warranties related to Licensee's access and use of the Platform under this Agreement shall apply to Licensee and all of Licensee's employees, contractors, consultants, representatives and agents (collectively, "Representatives"). Licensee shall be responsible for all acts and omissions of its Representatives in the performance of this Agreement and for any breach of this Agreement by any of its Representatives.

4. Intellectual Property.

4.1. Veritone Property. As between Veritone and Licensee, Veritone and/or its respective licensors retain all right, title and interest (including Intellectual Property Rights) in and to the Platform and Services, including, but not limited to any

elements, components, content, technology, software, code, documentation, derivative works, revisions, enhancements, modifications, condensations and/or compilations of or relating to the Platform and Services, and any trademarks, brand identifiers, materials and information, which are created, authored, developed, conceived and/or reduced to practice by Veritone and/or its respective licensors, including in connection with Veritone's provision of the Platform and Services to Licensee under this Agreement ("**Veritone Property**").

4.2. Licensee Property. As between Licensee and Veritone, Licensee retains all right, title and interest (including Intellectual Property Rights) in and to the Licensee Content, and any software, technology, trademarks, brand identifiers, materials and information which are independently created, authored, developed, conceived or reduced to practice by Licensee.

5. Licensee Content.

5.1. Content Ownership. Licensee represents and warrants that (i) Licensee and/or its licensors own all right, title and interest in and to all Licensee Content uploaded to or transmitted through the Platform or Services, or otherwise have all rights in such Licensee Content as necessary to use the same in connection with Licensee's use of the Platform and Services, (ii) such Licensee Content does not and will not misappropriate or infringe upon any third party's Intellectual Property Rights, or violate any other rights of any third party, and (iii) Licensee has all rights in such Licensee Content necessary to grant the rights contemplated by this Agreement.

5.2. License to Content. Unless otherwise specified in the License Agreement, Licensee hereby grants to Veritone a non-exclusive, royalty-free, worldwide license (i) to use and display all Licensee Content that Licensee provides to Veritone or that are otherwise uploaded to or captured by the Platform through Licensee's use of the Platform and Services to provide the Services and perform its obligations under this Agreement, directly or through its third party service providers, and (ii) to share such Licensee Content with Veritone's third party service providers solely as required for Veritone's provision of the Platform and Services to Licensee.

5.3. Data Security and Destruction. Veritone will maintain and use adequate administrative, physical, and technical safeguards for protection of the security, confidentiality and integrity of all Licensee Content uploaded to or transmitted through the Platform or Services. Licensee Content shall be used and stored by Veritone solely to the extent required to provide the Services and perform its obligations under this Agreement or as otherwise expressly provided in the License Agreement, and Veritone shall not use or store the Licensee Content for any other purpose whatsoever. Upon termination of this Agreement or upon the written request of Licensee at any time, Veritone shall ensure the secure deletion and destruction of all Licensee Content.

6. Feedback. During the Term, Licensee may provide Veritone with such written evaluations, comments and/or suggestions (collectively, "**Feedback**") regarding the Platform or Services. Licensee acknowledges and agrees that any Feedback provided to Veritone by Licensee hereunder shall be deemed to be Veritone Property and Licensee hereby assigns all right, title and interest in and to such Feedback to Veritone and acknowledges that Veritone will be entitled to, without limitation, implement and exploit any such Feedback in any manner without any restriction or obligation. Notwithstanding the foregoing, Licensee acknowledges that Veritone is not obligated to act on any such Feedback.

7. Term and Termination.

7.1. Term. The term of this Agreement and the License shall be as set forth in the License Agreement (the "**Term**").

7.2. Termination. In addition to any termination rights expressly provided in the License Agreement, this Agreement may be terminated by either party if the other party (i) materially breaches any provision of this Agreement which remains uncured for a period of fourteen (14) days from the date of written notice of such breach; or (ii) makes an assignment for the benefit of its creditors, is declared insolvent, or has a receiver or trustee in bankruptcy appointed to take charge of all or part of such party's property.

7.3. Effect of Termination. If at any time this Agreement is terminated, or upon expiration of the Term, the License and all other rights granted to Licensee herein shall automatically terminate and Licensee shall immediately cease using the Platform and Services.

7.4. Survival. The provisions of Sections 2.2 (Reservation of Rights), 4 (Intellectual Property), 6 (Feedback), 7.3 (Effect of Termination), 8.1 (Fees and Payments), 8.2 (Taxes), 10 (Confidentiality), 11 (Indemnification), 12.2 and 12.3 (Warranty and Disclaimers), 13 (Limitation of Liability), 14 (Miscellaneous) hereof and the payment terms of License Agreement, as applicable, shall survive the expiration or any early termination of this Agreement for any reason.

8. Fees, Charges and Payments.

8.1. Fees and Payments. In consideration for the License and Licensee's access and use of the Platform and Services, Licensee shall pay the license fees, and any applicable additional fees, as set forth in the License Agreement (collectively, the "Fees"). All Fees and other amounts due under this Agreement are payable in U.S. dollars.

8.2. Taxes. All Fees and any other amounts due hereunder are exclusive of taxes and similar assessments which may be imposed on the delivery of the Platform and Services and any other transactions contemplated hereby. Licensee shall be solely responsible for the payment of any and all sales, use, value added, excise, import, or other similar taxes or payments in lieu thereof, including interest and penalties thereon, imposed by any authority, government or governmental agency arising out of or in connection with amounts due hereunder (other than those levied on Veritone's income), and Licensee shall make such payments, and timely file any return or information required by treaty, law, rule or regulation. Upon request, Licensee shall provide Veritone with documentation evidencing such payments. If Veritone is required to pay any such taxes, duties or fees, Licensee shall reimburse Veritone immediately upon receipt of Veritone's invoice thereof.

8.3. Suspension of Platform Access. In addition to Veritone's termination rights set forth herein and without prejudice to any other rights of Veritone at law or in equity, Veritone may suspend its performance under this Agreement and any other agreement with Licensee and Licensee's access to the Platform if Licensee fails to comply with any part of its payment obligations set forth herein. Such suspension of service shall not suspend or otherwise affect Licensee's payment obligations set forth herein.

9. Changes to Platform, Service and Fees. Veritone may, from time to time, in its sole discretion, make changes to the Platform and Services, or a portion thereof including, without limitation, formats, content, reports, functionality, and/or techniques ("Service Change"). In the event of a Service Change, Veritone may, adjust the Fees for the Platform and Services ("Fee Change") in writing. Such Fee Change shall become effective on the date stated in Veritone's notice to Licensee unless, within fifteen (15) days after a Fee Change notice that would result in an increase in the Fees, Licensee notifies Veritone in writing of its refusal to accept the Fee Change, in which event the applicable License to Licensee shall terminate as of the effective date of the change; provided, however, that if the Fee Change is an increase in the Fees, Veritone may, in its sole discretion, elect to rescind the Fee Change, in which case the Platform and Services, as changed, shall continue as provided herein.

10. Confidentiality.

10.1. Confidential Information. Each party (a receiving party) acknowledges and agrees that during the Term and in the course of using the Platform and Services and performing its duties under this Agreement, it may obtain information relating to the other party (a disclosing party), its and/or its customers', vendors', or third party service providers' business or technologies, which is of a confidential and proprietary nature ("**Confidential Information**"). Such Confidential Information may include, but is not limited to, trade secrets, know-how, inventions, techniques, processes, software, algorithms, programs, schematics, data, technology roadmap, sales and marketing plans, and any other information which the receiving party knows or has reason to know is, or which by its nature would reasonably be considered to be, confidential, proprietary or trade secret information of the other party. Without limiting the foregoing, Confidential Information of Veritone shall include the Platform, Services and all associated software and documentation, as well as Feedback or any results of the evaluation or testing of the Platform or Services. The receiving party shall at all times, both during the Term and for a period of three (3) years after its termination (or, in the case of the Platform, Services and any associated software or trade secrets, in perpetuity), keep in trust and confidence all Confidential Information of the disclosing party, and shall not (i) use such Confidential Information other than as expressly authorized under this Agreement or as required for the receiving party to perform its obligations under this Agreement, or (ii) disclose any Confidential Information of the disclosing party to third parties (other than to Veritone's third party service providers in connection with the performance of its obligations under this Agreement), without the disclosing party's prior written consent. The receiving party further agrees to immediately return to the disclosing party or destroy all Confidential Information (including all copies, extracts and summaries thereof) in the receiving party's possession, custody, or control upon the expiration or any termination of this Agreement. The obligations of confidentiality shall not apply to information which (a) has entered the public domain except where such entry is the result of the receiving party's breach of this Agreement; (b) prior to disclosure hereunder, was already in the receiving party's possession and not subject to any confidentiality obligations, as demonstrated by written evidence; (c) subsequent to disclosure hereunder is obtained by the receiving party on a non-confidential basis from a third party who has the right to disclose such information to the receiving party; or (d) has been independently developed by the receiving party without use of or reference to the disclosing party's Confidential Information, as demonstrated by written evidence.

10.2. Permitted Disclosures. The receiving party may make disclosures (i) as required by applicable law or the rules of an stock exchange on which such party's shares are then traded; or (ii) as compelled by court order issued by a court of competent

jurisdiction provided that the receiving party subject to such court order (a) provides the disclosing party with prompt written notice of any such compelled disclosure, (b) uses diligent reasonable efforts to limit disclosure, (c) uses commercially reasonable efforts to obtain confidential treatment or a protective order in connection with the information subject to such compelled disclosure, and (d) allows the disclosing party to participate in any such proceeding.

11. Indemnification.

11.1. Licensee Indemnification of Veritone. Licensee will defend, indemnify and hold harmless Veritone and its subsidiaries, affiliates, successors, assigns, licensors, and their respective members, officers, directors, employees, licensors, agents, from and against any liability or expense, including, without limitation, any expenses, losses, damages, judgments, litigation costs and reasonable attorneys' fees, that Veritone may incur as a result of any claim, suit or proceeding brought against Veritone by any third party arising or resulting from (a) Licensee's breach of any representation, warranty, covenant or obligation contained in this Agreement; or (b) Licensee's use of the Platform or Services (including uploading, using, publishing, posting or otherwise sharing of Licensee's Content or any other data or content derived from the Platform or Services) in any manner that violates this Agreement or any laws, rules, regulations or third party terms and conditions, or that misappropriates or infringes the rights (including Intellectual Property Rights) of any third party; *provided that* Veritone gives Licensee prompt notice of any such claims, cooperates with Licensee in responding to such claims, and permits Licensee to control the defense or settlement of such claims, subject to Veritone's right to (i) conduct the defense of such claims at Veritone's expense, or participate in the defense of such claims with its own counsel at its own expense, and (ii) approve any settlement that binds or purports to bind Veritone.

11.2. Veritone Indemnification of Licensee. Veritone will defend, indemnify and hold harmless Licensee and its subsidiaries, affiliates, successors, assigns, licensors, and their respective members, officers, directors, employees, licensors, agents, from and against any liability or expense, including without limitation, any expenses, losses, damages, judgments, litigation costs and reasonable attorneys' fees that Licensee may incur as a result of any claim, suit or proceeding brought against Licensee by any third party arising or resulting from (a) Veritone's breach of any representation, warranty, covenant or obligation contained in this Agreement; or (b) any allegation that the Platform or Services, or any part thereof, misappropriates or infringes upon any third party's Intellectual Property Rights, except to the extent such claims arise from Licensee's negligence, misconduct or violation of any terms of this Agreement; *provided that* Licensee gives Veritone prompt notice of any such claims, cooperates with Veritone in responding to such claims, and permits Veritone to control the defense or settlement of such claims, subject to Licensee's right to (i) conduct the defense of such claims at Licensee's expense, or participate in the defense of such claims with its own counsel at its own expense, and (ii) approve any settlement that binds or purports to bind Licensee. If the Platform, in whole in part, becomes or, in Veritone's opinion is likely to become, the subject of an infringement claim or action, Veritone may, at its option: (x) procure, at no cost to Licensee, the right for Licensee to continue using the Platform; (y) replace or modify the Platform to render the Platform non-infringing, provided there is no material loss of functionality; or (z) if, in Veritone's reasonable opinion, neither (x) nor (y) above is commercially feasible, terminate this Agreement and refund any prepaid amounts for unused Services during the terminated portion of the Term. The foregoing states Veritone's sole obligation and Licensee's exclusive remedy in the event any such infringement claim or action is commenced or is likely to be commenced.

12. Warranties and Disclaimers.

12.1. Mutual Warranties. Each party represents and warrants to the other that: (i) it is duly organized and validly existing under the laws of the jurisdiction of its incorporation or formation, and has full power, rights and authority to enter into this Agreement and carry out its obligations hereunder; (ii) the person executing this Agreement is authorized to do so on its behalf; (iii) this Agreement is valid and legally binding upon it and (iv) the execution, delivery and performance thereof by such party does not conflict with any other agreement, instrument or understanding to which it is a party or by which it may be bound, nor would violate any applicable law or regulation.

12.2. Disclaimer. THE PLATFORM, SERVICES AND ANY OTHER VERITONE PRODUCTS AND SERVICES ARE PROVIDED ON AN "AS IS" AND "AS AVAILABLE" BASIS. EXCEPT AS EXPRESSLY PROVIDED IN THIS AGREEMENT, VERITONE MAKES NO WARRANTY, EXPRESS OR IMPLIED, WITH RESPECT TO THE PLATFORM AND SERVICES, INCLUDING, WITHOUT LIMITATION, ANY WARRANTY AS TO THE ACCURACY OF PROCESSING RESULTS, ANY WARRANTY OF MERCHANTABILITY, QUALITY OR FITNESS FOR A PARTICULAR PURPOSE, WARRANTIES ARISING FROM COURSE OF DEALING OR USAGE OF TRADE, AND WARRANTIES OF NON-INFRINGEMENT. VERITONE DOES NOT WARRANT THAT THE PLATFORM AND SERVICES ARE ERROR-FREE, WILL RUN UNINTERRUPTED, OR THAT ALL ERRORS CAN OR WILL BE CORRECTED. NO ADVICE OR INFORMATION, WHETHER ORAL OR WRITTEN, OBTAINED BY LICENSEE FROM VERITONE SHALL CREATE ANY SUCH WARRANTY.

12.3. LICENSEE ACKNOWLEDGES AND AGREES THAT THE INTERNET IS A PUBLIC NETWORK OVER WHICH VERITONE EXERTS NO CONTROL. VERITONE MAKES NO REPRESENTATIONS OR WARRANTIES WHATSOEVER, AND SHALL HAVE NO LIABILITY WHATSOEVER, WITH RESPECT TO THE ACCURACY, DEPENDABILITY, PRIVACY, SECURITY, AUTHENTICITY OR COMPLETENESS OF DATA TRANSMITTED OVER OR OBTAINED USING THE INTERNET OUTSIDE OF THOSE SYSTEMS AND NETWORKS CONTROLLED BY VERITONE, OR ANY INTRUSION, VIRUS, DISRUPTION, LOSS OF COMMUNICATION, LOSS OR CORRUPTION OF DATA, OR OTHER ERROR OR EVENT CAUSED OR PERMITTED BY OR INTRODUCED THROUGH LICENSEE'S OWN USE OF THE INTERNET. LICENSEE IS SOLELY RESPONSIBLE FOR IMPLEMENTING ADEQUATE FIREWALL, PASSWORD AND OTHER SECURITY MEASURES TO PROTECT ITS SYSTEMS, DATA AND APPLICATIONS FROM UNWANTED INTRUSION, WHETHER OVER THE INTERNET OR BY OTHER MEANS.

13. Limitation of Liability.

13.1. EXCEPT FOR (A) BREACHES OF EACH PARTY'S OBLIGATIONS UNDER SECTION 10 (CONFIDENTIALITY), AND (B) AMOUNTS FINALLY AWARDED OR SETTLED IN A THIRD PARTY CLAIM FOR WHICH A PARTY IS RESPONSIBLE UNDER SECTION 11 (INDEMNIFICATION), NEITHER PARTY, INCLUDING ITS OFFICERS, DIRECTORS, EMPLOYEES, REPRESENTATIVES AND AFFILIATES, SHALL BE LIABLE FOR ANY INDIRECT, INCIDENTAL, SPECIAL, CONSEQUENTIAL, OR PUNITIVE DAMAGES, INCLUDING WITHOUT LIMITATION, LOST DATA OR LOST PROFITS, OR COSTS OF PROCURING SUBSTITUTE GOODS OR SERVICES, HOWEVER ARISING, EVEN IF IT HAS BEEN ADVISED OF THE POSSIBILITY OF SUCH DAMAGES.

13.2. EXCEPT WITH RESPECT TO EACH PARTY'S CONFIDENTIALITY AND INDEMNIFICATION OBLIGATIONS HEREUNDER, NEITHER PARTY'S LIABILITY FOR DAMAGES ARISING OUT OF, RELATING TO OR IN ANY WAY CONNECTED WITH THIS AGREEMENT SHALL EXCEED THE TOTAL FEES PAID BY LICENSEE TO VERITONE UNDER THIS AGREEMENT.

14. MISCELLANEOUS

14.1. No Assignment. Neither party may assign any of its rights or obligations under this Agreement without the prior written consent of the other party, except that either party may assign its rights and obligations under this Agreement without the consent of the other party to an affiliate directly or indirectly controlling, controlled by, or under direct or indirect common control with such party or in connection with any merger (by operation of law or otherwise), consolidation, reorganization, change in control or sale of all or substantially all of its assets related to this Agreement or similar transaction. This Agreement inures to the benefit of and shall be binding on the parties' permitted assignees, transferees and successors.

14.2. Severability. If any provision of this Agreement is found by a court of competent jurisdiction to be invalid, the parties nevertheless agree that the court should endeavor to give effect to the parties' intentions as reflected in such provision, and the other provisions of this Agreement remain in full force and effect.

14.3. No Waiver. The failure of either party to exercise or enforce any right or provision of this Agreement shall not constitute a waiver of such right or provision.

14.4. Controlling Law. This Agreement shall be governed by and construed in accordance with the laws of the State of California (other than the conflict of law rules) and subject to the sole jurisdiction of the courts sitting in Orange County, California. Notwithstanding the foregoing, nothing in this Section 14.4 shall be deemed to limit the parties' rights to seek injunctive relief in any other court of law of competent jurisdiction.

14.5. Independent Contractors. This Agreement does not create any relationship other than Veritone as an independent contractor performing services covered by this Agreement and Licensee as the party contracting with Veritone for those services. No party is a partner or a legal representative of the other for any purpose whatsoever, nor is any party authorized to make any contract, agreement or warranty on behalf of any other party. Under no circumstance shall one party's employees be construed to be employees of the other party.

14.6. Publicity. Except as required or compelled by applicable law, the rules of any stock exchange, or a court order issued by a court of competent jurisdiction, neither party will make any public statement regarding, or disclose, advertise or publish the terms and conditions of this Agreement without the prior written consent of the other party; provided, however, that Veritone may reference Licensee on Veritone's website, other marketing materials, investor relations materials, and as a customer in Veritone's SEC filings.

14.7. Notices. All notices to either party shall be in writing and delivered by hand or by certified mail or overnight delivery service to the address set forth by Licensee and/or Veritone in the License Agreement, or to such other address as either party shall provide by notice to the other party. Alternatively, the parties may, at their election, utilize email as the method of delivery of any such notice to be provided hereunder. Any such notices sent by email shall be delivered to the email addresses set forth in the License Agreement, or such other email address as designed by a party during the Term. Notices shall be deemed effective when delivered to the applicable address, unless any such notice is sent by

email, in which event, notice shall be deemed effective upon confirmation of delivery by a “read receipt” or other such notice generated by the applicable email system, but in any event, by reply of the recipient of such notice.

- 14.8. Electronic Communication.** In connection with its use of the Platform and Services, Licensee consents to receiving communications from Veritone electronically. Veritone will communicate with Licensee by e-mail or by posting notices on the Platform or through any Services. Licensee agrees that all notices, disclosures and other communications that Veritone provides to Licensee electronically satisfy any legal requirement that such communications be in writing.
- 14.9. Force Majeure.** Except for the obligation to make payments of any Fees or any other amounts due hereunder, neither party will be liable for any failure or delay in its performance under the Agreement due to any cause beyond such party’s control including acts of war, terrorism, acts of God, embargo, riot, sabotage, labor shortage or dispute, governmental act, or failure of the Internet, or any component comprising or operating the network infrastructure thereof (each, a “**Force Majeure Event**”), provided that the delayed party: (i) gives the other party prompt notice of such cause, and (ii) uses its reasonable commercial efforts to promptly correct such failure or delay in performance. If Veritone is unable to provide Service(s) for a period of sixty (60) consecutive days as a result of a continuing Force Majeure Event, either party may elect to terminate this Agreement.
- 14.10. Construction.** This Agreement shall be fairly interpreted and construed in accordance with its terms and without strict interpretation or construction in favor of or against either party. Each party has had the opportunity to consult with counsel in the negotiation of this Agreement.
- 14.11. Counterparts.** This Agreement may be executed in one or more counterparts (including fax or email) each of which shall be deemed an original but all of which taken together shall be deemed one and the same instrument.
- 14.12. Headings.** Unless otherwise expressly stated in this Agreement, the words “herein,” “hereof,” “hereto,” and “hereunder” and other words of similar import refer to this Agreement as a whole and not to any particular section, subsection, or other subdivision. The words “include” and “including” shall not be construed or interpreted as terms of limitation. The words “day,” “month,” and “year” mean, respectively, calendar day, calendar month, and calendar year. Section headings are for reference purposes only, and should not be used in the interpretation hereof.
- 14.13. Amendment.** No addendum, waiver, consent, modification, amendment or change of the terms of this Agreement shall bind either party unless in a writing that references this Agreement and is signed by duly authorized representatives of Licensee and Veritone.
- 14.14. Attorney’s Fees.** If any action arises under this Agreement, including, without limitation the interpretation or enforcement of any term of this Agreement, the prevailing party in any such action shall be entitled to recover its reasonable attorney’s fees and related costs.

From: William Hillyard
Sent: Thursday, January 31, 2019 8:13 AM PST
To: Mark Anderson
Subject: FW: Veritone pilot agreement
Attachments: image001.png, ATT00001.htm, Irvine PD Data Sharing Addendum (20190128).docx, ATT00002.htm, Irvine Police Department License Agreement (iIdentify) (20190128).docx, ATT00003.htm, Master License Terms and Conditions (PS Rev 20180907).pdf, ATT00004.htm, image001.png, ATT00005.htm

LT,

Attached are the documents for the Pilot Program agreement with Veritone that need Chief Hamel's signature. Here are some brief points regarding the agreements:

- Irvine PD can opt out of the data sharing portion of the software at any time. If we did opt out but continued to use the software the suspect photos would only be compared to our database of known offenders, and no other agencies would have access to our database of booking photos and known offenders.
- The free trial period for the Pilot Program is 90 days, not 60 as was discussed during our meeting with Veritone.
- The initial License Agreement states that we will have (5) user profiles. This is only for the term of the Pilot Program. If we go forward with purchasing the software we will have an unlimited number of user licenses.
- Section 5.3 of the Master License Terms and Conditions states that if we cancel our relationship with Veritone any data we have provided them is removed from their servers and deleted. There are several portions throughout the agreements which clearly spell out that the data provided by Irvine PD remains the property of Irvine PD and should we terminated our contract with them they have no rights to retain or continue to use any data we provided them.
- The data we are providing other agencies access to through Veritone is no different than the data we upload to Coplink on a daily basis.
- For the Pilot Program we will provide Veritone with an initial data dump of our current database of booking photos, if we go forward with purchasing the software Veritone can set up and automated upload of new booking photos so there is no additional workload for our personnel.

I spoke with Nick Rycroft Monday reference the IT portion of it and he stated when the agreement is signed by the Chief he would begin working on the data export as requested by Veritone.

Please let me know if can provide any additional information.

Thank you,

Bill Hillyard

Begin forwarded message:

From: Tom Avery <tavery@veritone.com>
Date: January 30, 2019 at 7:15:09 AM PST
To: William Hillyard <whillyard@cityofirvine.org>
Subject: Veritone pilot agreement

Bill,

Attached is the Veritone pilot agreement documents which also include the terms and conditions as well as the data sharing agreement. Let me know if you have any questions.

Thanks,
Tom

Tom Avery
Vice President Public Safety
Veritone Government
tavery@veritone.com

Privacy cell

**Veritone IDentify Application
Data Sharing Addendum**

This Data Sharing Addendum (“Addendum”) is entered into as of February __, 2019, by and between Veritone, Inc. (“Veritone”) and Irvine Police Department (“Licensee”). This Addendum is incorporated by reference into, made a part of and governed by the terms of the License Agreement dated February __, 2019 between Veritone and Licensee (the “Agreement”). In the event of any conflict or inconsistency between the provisions contained in the Agreement and the provisions contained in this Addendum with respect to the subject matter hereof, the provisions of this Addendum shall govern and control. Capitalized terms used but not defined herein shall have the meanings ascribed to them in the Agreement.

1. **IDentify Application.** Veritone has granted to Licensee a right and license to access and use the IDentify Application within the Platform. The IDentify Application allows users to upload booking, arrest and known offender databases (collectively, “Booking Databases”) and use facial recognition technology to compare digital evidence from crime scenes with the Booking Databases to identify potential suspects. The IDentify Application also allows Licensee and other judicial and law enforcement agencies (each, an “Agency”) to elect to share access to their Booking Databases as further described in this Addendum (the “Data Sharing Option”).
2. **Participation in Data Sharing Option.** By executing this Addendum, Licensee hereby elects to participate in the Data Sharing Option, and each of Licensee and Veritone acknowledges and agrees to the supplemental terms and conditions applicable to the Data Sharing Option as set forth in this Addendum, in addition to the terms of the Agreement. All rights granted by each party under this Addendum shall continue during the Term of the Agreement, unless earlier terminated as set forth herein.
3. **Databases.**
 - (a) **Shared Databases.** Licensee will participate in the Data Sharing Option with respect to the Booking Databases indicated below (the option indicated below referred to hereinafter as the “Shared Databases”) (*check/complete one option*):
 - The Booking Databases maintained in the Platform by all other Agencies participating in the Data Sharing Option; or
 - The Booking Databases maintained in the Platform by the following Agencies:
 1. N/A
 - 2.
 - 3.
 - 4.
 - (b) **Access to Licensee Databases.** Licensee hereby grants to Veritone the right to grant access to all Booking Databases that Licensee maintains in the Platform (the “Licensee Databases”) to each other Agency that is participating in the Data Sharing Option and is maintaining a Shared Database in the Platform for use by each such Agency in connection with its use of the IDentify Application, and to other Agencies under limited trial licenses for evaluation purposes.
 - (c) **Access to Shared Databases.** Veritone will make available through the IDentify Application, and hereby grants to Licensee the right to access and use, the Shared Databases.
4. **Termination of Participation.** Licensee may terminate its participation in the Data Sharing Option by providing at least 60 days prior written notice to Veritone (or such shorter period as may be required by a court having jurisdiction). In such event, (i) Veritone will restrict access to the Licensee Databases to Licensee only and will terminate access to the Licensee Databases by any other Agency, and (ii) Veritone will terminate Licensee’s access to all Shared Databases, and Licensee’s use of the IDentify Application thereafter will be limited to use with the Licensee Databases only. Licensee acknowledges that Licensee’s right to access and use the Shared Databases is subject at all times to the participation by other Agencies in the Data Sharing Option on a continuous basis. If any Agency terminates its participation in the Data Sharing Option, Licensee will no longer

have access to the Shared Databases of such Agency or to any information generated from the Shared Databases associated with previously run searches and any resulting matches.

5. **Licensee Responsibilities.** Licensee shall be solely responsible for its use of the Shared Databases. Licensee represents and warrants that (a) it will use the Shared Databases solely in conjunction with its use of the IDentify Application in accordance with the terms of this Addendum, and (b) it will use the Shared Databases (including all data, content, materials, information and results contained in and/or generated from any of the foregoing) in compliance with all applicable laws, statutes, ordinances, rules, regulations, consent decrees, and/or requirements of any regulatory authority. Licensee shall defend, indemnify and hold harmless Veritone and its affiliates and licensors, and their respective members, officers, directors, employees, and agents, from and against any liability, losses, damages, judgments, costs and expenses, including litigation costs and reasonable attorneys' fees, arising out of or resulting from Licensee's use of the Shared Databases or Licensee's breach of any of its representations, warranties or obligations set forth in this Addendum.
6. **Authority.** The person executing this Addendum on behalf of each party represents and warrants that he or she has full authority to execute the same on behalf of such party, and that no other actions or approvals are required for such party to enter into this Addendum and perform its obligations hereunder.

IN WITNESS WHEREOF, the parties have caused this Addendum to be executed by their duly authorized representatives as of the date first above written.

VERITONE, INC.

Signature:

Name:

Title:

IRVINE POLICE DEPARTMENT

Signature:

Name:

Title:



LICENSE AGREEMENT

This License Agreement ("Agreement") is entered into as of the date of the last signature below ("Effective Date") by and between Veritone, Inc. (for itself and/or its subsidiaries), having a principal office located at 575 Anton Boulevard, Suite 100, Costa Mesa, CA 92626 ("Veritone") and the entity listed under Licensee Information below ("Licensee"), with respect to license(s) to Veritone's aiWARE Platform and related Services.

Table with sections: LICENSEE INFORMATION, LICENSE AND SERVICES DETAILS, and TERMS AND CONDITIONS. Includes fields for Agency Name, Address, Contact Info, Term, Users, Fees, and Services.

- 1. Master License Terms and Conditions. This Agreement and Licensee's access to and use of the Platform and Services shall be governed by the Veritone Master License Terms and Conditions attached hereto as Attachment A and incorporated herein by reference (the "Terms and Conditions").
2. Identify Application and Cognitive Processing. During the Term, Veritone will provide Licensee with access to the IDentify Application and the cognitive processing specified above for content uploaded to the Platform by Licensee through the IDentify Application.
3. Limitations. Licensee acknowledges that the IDentify Application is intended to be used by Licensee only as a tool to support review of digital evidence in connection with its investigations, and the IDentify Application and the results generated therefrom should not be considered or relied upon as a substitute for Licensee's customary investigative procedures, protocols and/or requirements.
4. Additional Services. Additional Services, such as on-site training, enhanced onboarding and/or support services, will be made available to Licensee for additional fees, which will be quoted by Veritone upon request.
5. Payment Terms. Veritone will submit an invoice to Licensee on a monthly basis for the License Fees due for the following month, and for any amounts incurred for additional Services performed during the previous month, and such invoices will be due and payable net thirty (30) days following the invoice date.

6. **Term and Termination.** Licensee may elect to terminate this Agreement at the expiration of the Trial Term specified above by providing thirty (30) days prior written notice to Veritone. Unless terminated at the expiration of the Trial Term or as otherwise provided herein, this Agreement will automatically continue following the Trial Term for the Initial Term specified above, and will automatically renew thereafter for successive one-year terms (each renewal term together with the Trial Term and Initial Term, collectively the "Term"). Following the Trial Term, either party may terminate this Agreement at any time, for any reason or no reason, by providing at least sixty (60) days prior written notice to the other party.
7. **Authority.** The person executing this Agreement on behalf of each party represents and warrants that he or she has full authority to execute the same on behalf of such party, and that no other actions or approvals are required for such party to enter into this Agreement and perform its obligations hereunder.

ACCEPTED AND AGREED BY:	
VERITONE, INC.	LICENSEE
Signature:	Signature:
Name:	Name:
Title:	Title:
Date:	Date:

ATTACHMENT A

**VERITONE, INC. MASTER LICENSE TERMS AND CONDITIONS
(PS-Rev 20180907)**

(Attached)

VERITONE, INC.

MASTER LICENSE TERMS AND CONDITIONS

These Master License Terms and Conditions (“Terms and Conditions”) apply to any License Agreement (as defined below) between Veritone, Inc. (or one of its subsidiaries) (“Veritone”) and a licensee (“Licensee”).

- 1. License Agreement; Controlling Terms.** For purposes hereof, “License Agreement” shall mean the written license agreement, or the order form, subscription form, statement of work or other document, including any addenda or exhibits thereto, accepted by Veritone in writing, that evidences the purchase of a license from Veritone by the Licensee (either directly or through an authorized reseller of Veritone) to access and use the Veritone aiWARE Platform (the “Platform”) and associated Services (as defined below). The Platform is an artificial intelligence operating system that delivers near real-time media processing and analytics, enabling users to process, index, organize, manage, search, analyze and share audio, video and other data through a suite of applications and other services (collectively, the “Services”). The specific Services, content, fees and payment terms, number of authorized users, and the term of license shall be as set forth in the License Agreement. The License Agreement may also contain other license-specific terms and conditions. The License Agreement and these Terms and Conditions are collectively referred to herein as this “Agreement.” In the event of any conflict or inconsistency among the terms and conditions set forth in the License Agreement and in these Terms and Conditions, the rights and obligations of the parties shall be interpreted based on the following order of priority: (1) the License Agreement and (2) these Terms and Conditions. This Agreement constitutes the complete and exclusive agreement between the parties with respect to the Platform and Services, superseding and replacing any and all prior agreements, communications, and understandings, both written and oral, regarding such subject matter, and no additional or different provision contained in any purchase order form, order acknowledgment form, invoice or similar form of either party will be effective.
- 2. License, Reservation of Rights, Restrictions.**
 - 2.1. License.** Veritone hereby grants to Licensee, during the Term (as defined in Section 7 below), a non-transferable, non-sublicensable, non-exclusive, revocable license to access and use the Platform and Services, subject to the terms and conditions set forth in this Agreement (the “License”). Licensee agrees to use the Platform and Services only for its internal business purposes in accordance with the terms of this Agreement. For the avoidance of doubt, the Platform and Services and its content may not be displayed publicly; provided that, subject to the provisions of Section 2.4 (Restrictions) and Section 11 (Indemnification) of this Agreement, Licensee may post, publish or otherwise share its owned or licensed content via the Platform for which sharing capabilities are enabled during the Term in accordance with the terms of this Agreement.
 - 2.2. Reservation of Rights.** The Platform and Services are licensed by Veritone to Licensee, and not sold. Licensee acquires only the right to use the Platform and Services in accordance with this Agreement and does not acquire any rights of ownership. Nothing herein shall be construed to transfer any rights, title or ownership of any Veritone or Veritone-licensed software, technology, materials, information or Intellectual Property Rights to Licensee. All right, title and interest (including all Intellectual Property Rights) in and to the Platform and Services shall at all times remain the sole and exclusive property of Veritone and/or its respective licensors and all use thereof shall inure to the benefit of Veritone and/or its respective licensors. Except as expressly set forth in this Agreement, no right or license, express or implied, is granted to Licensee or any third party by estoppel, implication, exhaustion or other doctrine of law, equity or otherwise with respect to any product, service, software, technology, materials, information or Intellectual Property Rights of Veritone or its affiliates or licensors. “**Intellectual Property Rights**” means all forms of proprietary rights, titles, interests, and ownership including patents, patent rights, copyrights, trademarks, trade dresses, trade secrets, know-how, mask works, *droit moral* (moral rights), publicity rights and all similar rights of every type that may exist now or in the future in any jurisdiction, including without limitation all applications and registrations therefore and rights to apply for any of the foregoing.
 - 2.3. Third Party Licenses.** Certain software components of the Platform and Services are supplied pursuant to license agreements from third parties, and Licensee agrees that Licensee’s use of the Platform and Services shall be subject to the provisions of such third party license agreements.
 - 2.4. Restrictions.**
 - 2.4.1. License Restrictions.** Licensee agrees to use the Platform and Services only for lawful purposes and only as expressly authorized under this Agreement. Without limiting the generality of the foregoing, except as expressly authorized hereunder, Licensee agrees that it shall not, directly or indirectly: (i) license, sublicense, sell, resell, rent, lease, transfer, assign, distribute, display or otherwise make the Platform or Services, in whole or in part, including any content or data derived therefrom that is not directly owned by Licensee or for which Licensee has

all necessary rights, available to any third party, or use the Platform or Services to provide services to any third party; (ii) reverse engineer, decompile, disassemble, modify, translate, reconstruct, omit, distort, obscure, copy or create derivative works of all or any portion of the Platform, Services, any underlying software, or any other Veritone Property (as defined below), or otherwise attempt to access the source code of the Platform or Services; (iii) incorporate any portion of the Platform or Services into Licensee's own programs or compile any portion of them in combination with Licensee's own programs; (iv) store or otherwise capture to physical media, or enable a third party to store or capture, the Platform or Services or any portion thereof; (v) permit any persons, other than Licensee's authorized users for which Licensee has procured User IDs pursuant to the License Agreement, to access and use the Platform or Services; (vi) upload or transmit through the Platform or Services any material, content, media or data (collectively, "Licensee Content") with respect to which Licensee does not either own all right, title and interest or have the appropriate license(s) for lawful use, or otherwise violate or infringe upon the intellectual property rights of any third party in Licensee's use of the Platform or Services, including the use or distribution of any data derived from the Platform or Services; or (vii) violate any laws, rules or regulations in connection with its use of the Platform or Services, including any data or content contained in, transmitted through or derived therefrom.

2.4.2. Prohibited Acts. Licensee acknowledges and agrees that Licensee is prohibited from doing any act that may have the effect of undermining the integrity of the Platform, Services, any related computer systems, infrastructure or environment, or the methods by which Veritone provides Services to users. Without limiting the generality of the foregoing, Licensee agrees that it shall not, directly or indirectly: (i) defeat, circumvent or modify any authentication technology or other security measures, controls, limitations, or content or functionality filters contained in or associated with the Platform or Services, or otherwise attempt to access any aspect of the Platform or Services that Licensee has not been granted authorization to access under the License Agreement; (ii) deploy or facilitate the use or deployment of any script, routine, robot, spider, scraper or any other automated means, method or device with respect to Licensee's access and use of the Platform and Services for any purpose, including to access, view, select, or copy in whole or in part, any content, program, functionality of the Platform or Services, or any other proprietary information or trade secret of Veritone that is made available through the Platform or Services; (iii) deploy or facilitate the use or deployment of any program, system, means, method or device, for any purpose that places an unreasonable, unnecessary or excessive demand or load on the Platform, Services, or related hardware and connections, or prohibits, denies or delays access to Services by other users or otherwise threatens the continuous services of Veritone's ISPs, suppliers and vendors; (iv) introduce into the Platform or Services any program, executable file or routine (such as a worm, Trojan horse, cancel-bot, time bomb or virus) irrespective of whether any such program or routine results in detrimental harm to the Platform, Services, or any underlying systems or programs; (v) remove any proprietary notices, labels or marks from the Platform or Services; (vi) establish any direct or deep link or other connection to any specific page or location within the Platform or Services, other than the Platform log-in page; (vii) use or attempt to use another user's account without authorization, or interfere with another user's access to the Platform or Services; or (viii) access or use the Platform or Services to design, develop, build, market or support a competitive product or service.

3. Access and Use. Veritone will enable Licensee to access and use the Platform for the duration of the Term, subject to any early termination of this Agreement in accordance with the terms hereof. Access to the Platform will be through unique log-in credentials assigned to Licensee by Veritone (each, a "User ID"). Licensee shall be given that number of User IDs as specified in the License Agreement. Licensee will provide accurate and complete information in registering its authorized users for account access. Licensee acknowledges and agrees that the log-in credentials assigned hereunder are Confidential Information and may only be used by Licensee and its authorized users to access the Platform in accordance with the terms of this Agreement, and that Licensee will not publish, share, or otherwise enable any third party, directly or indirectly, to access the Platform for any purpose. Licensee further agrees that Licensee is responsible for its and its authorized users' use of the Platform, including use via the User IDs, and for any consequences thereof. Licensee agrees to immediately notify Veritone of any unauthorized or improper use of any log-in credentials of Licensee. All of the rights, obligations, restrictions, representations and warranties related to Licensee's access and use of the Platform under this Agreement shall apply to Licensee and all of Licensee's employees, contractors, consultants, representatives and agents (collectively, "Representatives"). Licensee shall be responsible for all acts and omissions of its Representatives in the performance of this Agreement and for any breach of this Agreement by any of its Representatives.

4. Intellectual Property.

4.1. Veritone Property. As between Veritone and Licensee, Veritone and/or its respective licensors retain all right, title and interest (including Intellectual Property Rights) in and to the Platform and Services, including, but not limited to any

elements, components, content, technology, software, code, documentation, derivative works, revisions, enhancements, modifications, condensations and/or compilations of or relating to the Platform and Services, and any trademarks, brand identifiers, materials and information, which are created, authored, developed, conceived and/or reduced to practice by Veritone and/or its respective licensors, including in connection with Veritone's provision of the Platform and Services to Licensee under this Agreement ("**Veritone Property**").

4.2. Licensee Property. As between Licensee and Veritone, Licensee retains all right, title and interest (including Intellectual Property Rights) in and to the Licensee Content, and any software, technology, trademarks, brand identifiers, materials and information which are independently created, authored, developed, conceived or reduced to practice by Licensee.

5. Licensee Content.

5.1. Content Ownership. Licensee represents and warrants that (i) Licensee and/or its licensors own all right, title and interest in and to all Licensee Content uploaded to or transmitted through the Platform or Services, or otherwise have all rights in such Licensee Content as necessary to use the same in connection with Licensee's use of the Platform and Services, (ii) such Licensee Content does not and will not misappropriate or infringe upon any third party's Intellectual Property Rights, or violate any other rights of any third party, and (iii) Licensee has all rights in such Licensee Content necessary to grant the rights contemplated by this Agreement.

5.2. License to Content. Unless otherwise specified in the License Agreement, Licensee hereby grants to Veritone a non-exclusive, royalty-free, worldwide license (i) to use and display all Licensee Content that Licensee provides to Veritone or that are otherwise uploaded to or captured by the Platform through Licensee's use of the Platform and Services to provide the Services and perform its obligations under this Agreement, directly or through its third party service providers, and (ii) to share such Licensee Content with Veritone's third party service providers solely as required for Veritone's provision of the Platform and Services to Licensee.

5.3. Data Security and Destruction. Veritone will maintain and use adequate administrative, physical, and technical safeguards for protection of the security, confidentiality and integrity of all Licensee Content uploaded to or transmitted through the Platform or Services. Licensee Content shall be used and stored by Veritone solely to the extent required to provide the Services and perform its obligations under this Agreement or as otherwise expressly provided in the License Agreement, and Veritone shall not use or store the Licensee Content for any other purpose whatsoever. Upon termination of this Agreement or upon the written request of Licensee at any time, Veritone shall ensure the secure deletion and destruction of all Licensee Content.

6. Feedback. During the Term, Licensee may provide Veritone with such written evaluations, comments and/or suggestions (collectively, "**Feedback**") regarding the Platform or Services. Licensee acknowledges and agrees that any Feedback provided to Veritone by Licensee hereunder shall be deemed to be Veritone Property and Licensee hereby assigns all right, title and interest in and to such Feedback to Veritone and acknowledges that Veritone will be entitled to, without limitation, implement and exploit any such Feedback in any manner without any restriction or obligation. Notwithstanding the foregoing, Licensee acknowledges that Veritone is not obligated to act on any such Feedback.

7. Term and Termination.

7.1. Term. The term of this Agreement and the License shall be as set forth in the License Agreement (the "**Term**").

7.2. Termination. In addition to any termination rights expressly provided in the License Agreement, this Agreement may be terminated by either party if the other party (i) materially breaches any provision of this Agreement which remains uncured for a period of fourteen (14) days from the date of written notice of such breach; or (ii) makes an assignment for the benefit of its creditors, is declared insolvent, or has a receiver or trustee in bankruptcy appointed to take charge of all or part of such party's property.

7.3. Effect of Termination. If at any time this Agreement is terminated, or upon expiration of the Term, the License and all other rights granted to Licensee herein shall automatically terminate and Licensee shall immediately cease using the Platform and Services.

7.4. Survival. The provisions of Sections 2.2 (Reservation of Rights), 4 (Intellectual Property), 6 (Feedback), 7.3 (Effect of Termination), 8.1 (Fees and Payments), 8.2 (Taxes), 10 (Confidentiality), 11 (Indemnification), 12.2 and 12.3 (Warranty and Disclaimers), 13 (Limitation of Liability), 14 (Miscellaneous) hereof and the payment terms of License Agreement, as applicable, shall survive the expiration or any early termination of this Agreement for any reason.

8. Fees, Charges and Payments.

8.1. Fees and Payments. In consideration for the License and Licensee's access and use of the Platform and Services, Licensee shall pay the license fees, and any applicable additional fees, as set forth in the License Agreement (collectively, the "Fees"). All Fees and other amounts due under this Agreement are payable in U.S. dollars.

8.2. Taxes. All Fees and any other amounts due hereunder are exclusive of taxes and similar assessments which may be imposed on the delivery of the Platform and Services and any other transactions contemplated hereby. Licensee shall be solely responsible for the payment of any and all sales, use, value added, excise, import, or other similar taxes or payments in lieu thereof, including interest and penalties thereon, imposed by any authority, government or governmental agency arising out of or in connection with amounts due hereunder (other than those levied on Veritone's income), and Licensee shall make such payments, and timely file any return or information required by treaty, law, rule or regulation. Upon request, Licensee shall provide Veritone with documentation evidencing such payments. If Veritone is required to pay any such taxes, duties or fees, Licensee shall reimburse Veritone immediately upon receipt of Veritone's invoice thereof.

8.3. Suspension of Platform Access. In addition to Veritone's termination rights set forth herein and without prejudice to any other rights of Veritone at law or in equity, Veritone may suspend its performance under this Agreement and any other agreement with Licensee and Licensee's access to the Platform if Licensee fails to comply with any part of its payment obligations set forth herein. Such suspension of service shall not suspend or otherwise affect Licensee's payment obligations set forth herein.

9. Changes to Platform, Service and Fees. Veritone may, from time to time, in its sole discretion, make changes to the Platform and Services, or a portion thereof including, without limitation, formats, content, reports, functionality, and/or techniques ("Service Change"). In the event of a Service Change, Veritone may, adjust the Fees for the Platform and Services ("Fee Change") in writing. Such Fee Change shall become effective on the date stated in Veritone's notice to Licensee unless, within fifteen (15) days after a Fee Change notice that would result in an increase in the Fees, Licensee notifies Veritone in writing of its refusal to accept the Fee Change, in which event the applicable License to Licensee shall terminate as of the effective date of the change; provided, however, that if the Fee Change is an increase in the Fees, Veritone may, in its sole discretion, elect to rescind the Fee Change, in which case the Platform and Services, as changed, shall continue as provided herein.

10. Confidentiality.

10.1. Confidential Information. Each party (a receiving party) acknowledges and agrees that during the Term and in the course of using the Platform and Services and performing its duties under this Agreement, it may obtain information relating to the other party (a disclosing party), its and/or its customers', vendors', or third party service providers' business or technologies, which is of a confidential and proprietary nature ("**Confidential Information**"). Such Confidential Information may include, but is not limited to, trade secrets, know-how, inventions, techniques, processes, software, algorithms, programs, schematics, data, technology roadmap, sales and marketing plans, and any other information which the receiving party knows or has reason to know is, or which by its nature would reasonably be considered to be, confidential, proprietary or trade secret information of the other party. Without limiting the foregoing, Confidential Information of Veritone shall include the Platform, Services and all associated software and documentation, as well as Feedback or any results of the evaluation or testing of the Platform or Services. The receiving party shall at all times, both during the Term and for a period of three (3) years after its termination (or, in the case of the Platform, Services and any associated software or trade secrets, in perpetuity), keep in trust and confidence all Confidential Information of the disclosing party, and shall not (i) use such Confidential Information other than as expressly authorized under this Agreement or as required for the receiving party to perform its obligations under this Agreement, or (ii) disclose any Confidential Information of the disclosing party to third parties (other than to Veritone's third party service providers in connection with the performance of its obligations under this Agreement), without the disclosing party's prior written consent. The receiving party further agrees to immediately return to the disclosing party or destroy all Confidential Information (including all copies, extracts and summaries thereof) in the receiving party's possession, custody, or control upon the expiration or any termination of this Agreement. The obligations of confidentiality shall not apply to information which (a) has entered the public domain except where such entry is the result of the receiving party's breach of this Agreement; (b) prior to disclosure hereunder, was already in the receiving party's possession and not subject to any confidentiality obligations, as demonstrated by written evidence; (c) subsequent to disclosure hereunder is obtained by the receiving party on a non-confidential basis from a third party who has the right to disclose such information to the receiving party; or (d) has been independently developed by the receiving party without use of or reference to the disclosing party's Confidential Information, as demonstrated by written evidence.

10.2. Permitted Disclosures. The receiving party may make disclosures (i) as required by applicable law or the rules of an stock exchange on which such party's shares are then traded; or (ii) as compelled by court order issued by a court of competent

jurisdiction provided that the receiving party subject to such court order (a) provides the disclosing party with prompt written notice of any such compelled disclosure, (b) uses diligent reasonable efforts to limit disclosure, (c) uses commercially reasonable efforts to obtain confidential treatment or a protective order in connection with the information subject to such compelled disclosure, and (d) allows the disclosing party to participate in any such proceeding.

11. Indemnification.

11.1. Licensee Indemnification of Veritone. Licensee will defend, indemnify and hold harmless Veritone and its subsidiaries, affiliates, successors, assigns, licensors, and their respective members, officers, directors, employees, licensors, agents, from and against any liability or expense, including, without limitation, any expenses, losses, damages, judgments, litigation costs and reasonable attorneys' fees, that Veritone may incur as a result of any claim, suit or proceeding brought against Veritone by any third party arising or resulting from (a) Licensee's breach of any representation, warranty, covenant or obligation contained in this Agreement; or (b) Licensee's use of the Platform or Services (including uploading, using, publishing, posting or otherwise sharing of Licensee's Content or any other data or content derived from the Platform or Services) in any manner that violates this Agreement or any laws, rules, regulations or third party terms and conditions, or that misappropriates or infringes the rights (including Intellectual Property Rights) of any third party; *provided that* Veritone gives Licensee prompt notice of any such claims, cooperates with Licensee in responding to such claims, and permits Licensee to control the defense or settlement of such claims, subject to Veritone's right to (i) conduct the defense of such claims at Veritone's expense, or participate in the defense of such claims with its own counsel at its own expense, and (ii) approve any settlement that binds or purports to bind Veritone.

11.2. Veritone Indemnification of Licensee. Veritone will defend, indemnify and hold harmless Licensee and its subsidiaries, affiliates, successors, assigns, licensors, and their respective members, officers, directors, employees, licensors, agents, from and against any liability or expense, including without limitation, any expenses, losses, damages, judgments, litigation costs and reasonable attorneys' fees that Licensee may incur as a result of any claim, suit or proceeding brought against Licensee by any third party arising or resulting from (a) Veritone's breach of any representation, warranty, covenant or obligation contained in this Agreement; or (b) any allegation that the Platform or Services, or any part thereof, misappropriates or infringes upon any third party's Intellectual Property Rights, except to the extent such claims arise from Licensee's negligence, misconduct or violation of any terms of this Agreement; *provided that* Licensee gives Veritone prompt notice of any such claims, cooperates with Veritone in responding to such claims, and permits Veritone to control the defense or settlement of such claims, subject to Licensee's right to (i) conduct the defense of such claims at Licensee's expense, or participate in the defense of such claims with its own counsel at its own expense, and (ii) approve any settlement that binds or purports to bind Licensee. If the Platform, in whole in part, becomes or, in Veritone's opinion is likely to become, the subject of an infringement claim or action, Veritone may, at its option: (x) procure, at no cost to Licensee, the right for Licensee to continue using the Platform; (y) replace or modify the Platform to render the Platform non-infringing, provided there is no material loss of functionality; or (z) if, in Veritone's reasonable opinion, neither (x) nor (y) above is commercially feasible, terminate this Agreement and refund any prepaid amounts for unused Services during the terminated portion of the Term. The foregoing states Veritone's sole obligation and Licensee's exclusive remedy in the event any such infringement claim or action is commenced or is likely to be commenced.

12. Warranties and Disclaimers.

12.1. Mutual Warranties. Each party represents and warrants to the other that: (i) it is duly organized and validly existing under the laws of the jurisdiction of its incorporation or formation, and has full power, rights and authority to enter into this Agreement and carry out its obligations hereunder; (ii) the person executing this Agreement is authorized to do so on its behalf; (iii) this Agreement is valid and legally binding upon it and (iv) the execution, delivery and performance thereof by such party does not conflict with any other agreement, instrument or understanding to which it is a party or by which it may be bound, nor would violate any applicable law or regulation.

12.2. Disclaimer. THE PLATFORM, SERVICES AND ANY OTHER VERITONE PRODUCTS AND SERVICES ARE PROVIDED ON AN "AS IS" AND "AS AVAILABLE" BASIS. EXCEPT AS EXPRESSLY PROVIDED IN THIS AGREEMENT, VERITONE MAKES NO WARRANTY, EXPRESS OR IMPLIED, WITH RESPECT TO THE PLATFORM AND SERVICES, INCLUDING, WITHOUT LIMITATION, ANY WARRANTY AS TO THE ACCURACY OF PROCESSING RESULTS, ANY WARRANTY OF MERCHANTABILITY, QUALITY OR FITNESS FOR A PARTICULAR PURPOSE, WARRANTIES ARISING FROM COURSE OF DEALING OR USAGE OF TRADE, AND WARRANTIES OF NON-INFRINGEMENT. VERITONE DOES NOT WARRANT THAT THE PLATFORM AND SERVICES ARE ERROR-FREE, WILL RUN UNINTERRUPTED, OR THAT ALL ERRORS CAN OR WILL BE CORRECTED. NO ADVICE OR INFORMATION, WHETHER ORAL OR WRITTEN, OBTAINED BY LICENSEE FROM VERITONE SHALL CREATE ANY SUCH WARRANTY.

12.3. LICENSEE ACKNOWLEDGES AND AGREES THAT THE INTERNET IS A PUBLIC NETWORK OVER WHICH VERITONE EXERTS NO CONTROL. VERITONE MAKES NO REPRESENTATIONS OR WARRANTIES WHATSOEVER, AND SHALL HAVE NO LIABILITY WHATSOEVER, WITH RESPECT TO THE ACCURACY, DEPENDABILITY, PRIVACY, SECURITY, AUTHENTICITY OR COMPLETENESS OF DATA TRANSMITTED OVER OR OBTAINED USING THE INTERNET OUTSIDE OF THOSE SYSTEMS AND NETWORKS CONTROLLED BY VERITONE, OR ANY INTRUSION, VIRUS, DISRUPTION, LOSS OF COMMUNICATION, LOSS OR CORRUPTION OF DATA, OR OTHER ERROR OR EVENT CAUSED OR PERMITTED BY OR INTRODUCED THROUGH LICENSEE'S OWN USE OF THE INTERNET. LICENSEE IS SOLELY RESPONSIBLE FOR IMPLEMENTING ADEQUATE FIREWALL, PASSWORD AND OTHER SECURITY MEASURES TO PROTECT ITS SYSTEMS, DATA AND APPLICATIONS FROM UNWANTED INTRUSION, WHETHER OVER THE INTERNET OR BY OTHER MEANS.

13. Limitation of Liability.

13.1. EXCEPT FOR (A) BREACHES OF EACH PARTY'S OBLIGATIONS UNDER SECTION 10 (CONFIDENTIALITY), AND (B) AMOUNTS FINALLY AWARDED OR SETTLED IN A THIRD PARTY CLAIM FOR WHICH A PARTY IS RESPONSIBLE UNDER SECTION 11 (INDEMNIFICATION), NEITHER PARTY, INCLUDING ITS OFFICERS, DIRECTORS, EMPLOYEES, REPRESENTATIVES AND AFFILIATES, SHALL BE LIABLE FOR ANY INDIRECT, INCIDENTAL, SPECIAL, CONSEQUENTIAL, OR PUNITIVE DAMAGES, INCLUDING WITHOUT LIMITATION, LOST DATA OR LOST PROFITS, OR COSTS OF PROCURING SUBSTITUTE GOODS OR SERVICES, HOWEVER ARISING, EVEN IF IT HAS BEEN ADVISED OF THE POSSIBILITY OF SUCH DAMAGES.

13.2. EXCEPT WITH RESPECT TO EACH PARTY'S CONFIDENTIALITY AND INDEMNIFICATION OBLIGATIONS HEREUNDER, NEITHER PARTY'S LIABILITY FOR DAMAGES ARISING OUT OF, RELATING TO OR IN ANY WAY CONNECTED WITH THIS AGREEMENT SHALL EXCEED THE TOTAL FEES PAID BY LICENSEE TO VERITONE UNDER THIS AGREEMENT.

14. MISCELLANEOUS

14.1. No Assignment. Neither party may assign any of its rights or obligations under this Agreement without the prior written consent of the other party, except that either party may assign its rights and obligations under this Agreement without the consent of the other party to an affiliate directly or indirectly controlling, controlled by, or under direct or indirect common control with such party or in connection with any merger (by operation of law or otherwise), consolidation, reorganization, change in control or sale of all or substantially all of its assets related to this Agreement or similar transaction. This Agreement inures to the benefit of and shall be binding on the parties' permitted assignees, transferees and successors.

14.2. Severability. If any provision of this Agreement is found by a court of competent jurisdiction to be invalid, the parties nevertheless agree that the court should endeavor to give effect to the parties' intentions as reflected in such provision, and the other provisions of this Agreement remain in full force and effect.

14.3. No Waiver. The failure of either party to exercise or enforce any right or provision of this Agreement shall not constitute a waiver of such right or provision.

14.4. Controlling Law. This Agreement shall be governed by and construed in accordance with the laws of the State of California (other than the conflict of law rules) and subject to the sole jurisdiction of the courts sitting in Orange County, California. Notwithstanding the foregoing, nothing in this Section 14.4 shall be deemed to limit the parties' rights to seek injunctive relief in any other court of law of competent jurisdiction.

14.5. Independent Contractors. This Agreement does not create any relationship other than Veritone as an independent contractor performing services covered by this Agreement and Licensee as the party contracting with Veritone for those services. No party is a partner or a legal representative of the other for any purpose whatsoever, nor is any party authorized to make any contract, agreement or warranty on behalf of any other party. Under no circumstance shall one party's employees be construed to be employees of the other party.

14.6. Publicity. Except as required or compelled by applicable law, the rules of any stock exchange, or a court order issued by a court of competent jurisdiction, neither party will make any public statement regarding, or disclose, advertise or publish the terms and conditions of this Agreement without the prior written consent of the other party; provided, however, that Veritone may reference Licensee on Veritone's website, other marketing materials, investor relations materials, and as a customer in Veritone's SEC filings.

14.7. Notices. All notices to either party shall be in writing and delivered by hand or by certified mail or overnight delivery service to the address set forth by Licensee and/or Veritone in the License Agreement, or to such other address as either party shall provide by notice to the other party. Alternatively, the parties may, at their election, utilize email as the method of delivery of any such notice to be provided hereunder. Any such notices sent by email shall be delivered to the email addresses set forth in the License Agreement, or such other email address as designed by a party during the Term. Notices shall be deemed effective when delivered to the applicable address, unless any such notice is sent by

email, in which event, notice shall be deemed effective upon confirmation of delivery by a “read receipt” or other such notice generated by the applicable email system, but in any event, by reply of the recipient of such notice.

- 14.8. Electronic Communication.** In connection with its use of the Platform and Services, Licensee consents to receiving communications from Veritone electronically. Veritone will communicate with Licensee by e-mail or by posting notices on the Platform or through any Services. Licensee agrees that all notices, disclosures and other communications that Veritone provides to Licensee electronically satisfy any legal requirement that such communications be in writing.
- 14.9. Force Majeure.** Except for the obligation to make payments of any Fees or any other amounts due hereunder, neither party will be liable for any failure or delay in its performance under the Agreement due to any cause beyond such party’s control including acts of war, terrorism, acts of God, embargo, riot, sabotage, labor shortage or dispute, governmental act, or failure of the Internet, or any component comprising or operating the network infrastructure thereof (each, a “**Force Majeure Event**”), provided that the delayed party: (i) gives the other party prompt notice of such cause, and (ii) uses its reasonable commercial efforts to promptly correct such failure or delay in performance. If Veritone is unable to provide Service(s) for a period of sixty (60) consecutive days as a result of a continuing Force Majeure Event, either party may elect to terminate this Agreement.
- 14.10. Construction.** This Agreement shall be fairly interpreted and construed in accordance with its terms and without strict interpretation or construction in favor of or against either party. Each party has had the opportunity to consult with counsel in the negotiation of this Agreement.
- 14.11. Counterparts.** This Agreement may be executed in one or more counterparts (including fax or email) each of which shall be deemed an original but all of which taken together shall be deemed one and the same instrument.
- 14.12. Headings.** Unless otherwise expressly stated in this Agreement, the words “herein,” “hereof,” “hereto,” and “hereunder” and other words of similar import refer to this Agreement as a whole and not to any particular section, subsection, or other subdivision. The words “include” and “including” shall not be construed or interpreted as terms of limitation. The words “day,” “month,” and “year” mean, respectively, calendar day, calendar month, and calendar year. Section headings are for reference purposes only, and should not be used in the interpretation hereof.
- 14.13. Amendment.** No addendum, waiver, consent, modification, amendment or change of the terms of this Agreement shall bind either party unless in a writing that references this Agreement and is signed by duly authorized representatives of Licensee and Veritone.
- 14.14. Attorney’s Fees.** If any action arises under this Agreement, including, without limitation the interpretation or enforcement of any term of this Agreement, the prevailing party in any such action shall be entitled to recover its reasonable attorney’s fees and related costs.

From: Mark Anderson
Sent: Thursday, January 31, 2019 8:31 AM PST
To: Noelle Smiley
Subject: FW: Veritone pilot agreement
Attachments: image001.png, ATT00001.htm, Irvine PD Data Sharing Addendum (20190128).docx, ATT00002.htm, Irvine Police Department License Agreement (IDentify) (20190128).docx, ATT00003.htm, Master License Terms and Conditions (PS Rev 20180907).pdf, ATT00004.htm, image001.png, ATT00005.htm

Commander,

Reference the demo for the facial recognition software; we would like to move forward with the T & E trial period with the program. This is a free trial period for 90 days. Bill highlighted the details below. Please let me know if you need more info. If we do move forward with the purchase, the cost is \$20K/year.

Thank you,

Mark

From: William Hillyard
Sent: Thursday, January 31, 2019 8:13 AM
To: Mark Anderson <manderson@cityofirvine.org>
Subject: FW: Veritone pilot agreement

LT,

Attached are the documents for the Pilot Program agreement with Veritone that need Chief Hamel's signature. Here are some brief points regarding the agreements:

- Irvine PD can opt out of the data sharing portion of the software at any time. If we did opt out but continued to use the software the suspect photos would only be compared to our database of known offenders, and no other agencies would have access to our database of booking photos and known offenders.
- The free trial period for the Pilot Program is 90 days, not 60 as was discussed during our meeting with Veritone.
- The initial License Agreement states that we will have (5) user profiles. This is only for the term of the Pilot Program. If we go forward with purchasing the software we will have an unlimited number of user licenses.
- Section 5.3 of the Master License Terms and Conditions states that if we cancel our relationship with Veritone any data we have provided them is removed from their servers and deleted. There are several portions throughout the agreements which clearly spell out that the data provided by Irvine PD remains the property of Irvine PD and should we

terminated our contract with them they have no rights to retain or continue to use any data we provided them.

- The data we are providing other agencies access to through Veritone is no different than the data we upload to Coplink on a daily basis.
- For the Pilot Program we will provide Veritone with an initial data dump of our current database of booking photos, if we go forward with purchasing the software Veritone can set up and automated upload of new booking photos so there is no additional workload for our personnel.

I spoke with Nick Rycroft Monday reference the IT portion of it and he stated when the agreement is signed by the Chief he would begin working on the data export as requested by Veritone.

Please let me know if can provide any additional information.

Thank you,

Bill Hillyard

Begin forwarded message:

From: Tom Avery <tavery@veritone.com>
Date: January 30, 2019 at 7:15:09 AM PST
To: William Hillyard <whillyard@cityofirvine.org>
Subject: Veritone pilot agreement

Bill,

Attached is the Veritone pilot agreement documents which also include the terms and conditions as well as the data sharing agreement. Let me know if you have any questions.

Thanks,
Tom

Tom Avery
Vice President Public Safety
Veritone Government
tavery@veritone.com
Privacy cell

**Veritone IDentify Application
Data Sharing Addendum**

This Data Sharing Addendum (“Addendum”) is entered into as of February __, 2019, by and between Veritone, Inc. (“Veritone”) and Irvine Police Department (“Licensee”). This Addendum is incorporated by reference into, made a part of and governed by the terms of the License Agreement dated February __, 2019 between Veritone and Licensee (the “Agreement”). In the event of any conflict or inconsistency between the provisions contained in the Agreement and the provisions contained in this Addendum with respect to the subject matter hereof, the provisions of this Addendum shall govern and control. Capitalized terms used but not defined herein shall have the meanings ascribed to them in the Agreement.

1. **IDentify Application.** Veritone has granted to Licensee a right and license to access and use the IDentify Application within the Platform. The IDentify Application allows users to upload booking, arrest and known offender databases (collectively, “Booking Databases”) and use facial recognition technology to compare digital evidence from crime scenes with the Booking Databases to identify potential suspects. The IDentify Application also allows Licensee and other judicial and law enforcement agencies (each, an “Agency”) to elect to share access to their Booking Databases as further described in this Addendum (the “Data Sharing Option”).
2. **Participation in Data Sharing Option.** By executing this Addendum, Licensee hereby elects to participate in the Data Sharing Option, and each of Licensee and Veritone acknowledges and agrees to the supplemental terms and conditions applicable to the Data Sharing Option as set forth in this Addendum, in addition to the terms of the Agreement. All rights granted by each party under this Addendum shall continue during the Term of the Agreement, unless earlier terminated as set forth herein.
3. **Databases.**
 - (a) **Shared Databases.** Licensee will participate in the Data Sharing Option with respect to the Booking Databases indicated below (the option indicated below referred to hereinafter as the “Shared Databases”) (*check/complete one option*):
 - The Booking Databases maintained in the Platform by all other Agencies participating in the Data Sharing Option; or
 - The Booking Databases maintained in the Platform by the following Agencies:
 1. N/A
 - 2.
 - 3.
 - 4.
 - (b) **Access to Licensee Databases.** Licensee hereby grants to Veritone the right to grant access to all Booking Databases that Licensee maintains in the Platform (the “Licensee Databases”) to each other Agency that is participating in the Data Sharing Option and is maintaining a Shared Database in the Platform for use by each such Agency in connection with its use of the IDentify Application, and to other Agencies under limited trial licenses for evaluation purposes.
 - (c) **Access to Shared Databases.** Veritone will make available through the IDentify Application, and hereby grants to Licensee the right to access and use, the Shared Databases.
4. **Termination of Participation.** Licensee may terminate its participation in the Data Sharing Option by providing at least 60 days prior written notice to Veritone (or such shorter period as may be required by a court having jurisdiction). In such event, (i) Veritone will restrict access to the Licensee Databases to Licensee only and will terminate access to the Licensee Databases by any other Agency, and (ii) Veritone will terminate Licensee’s access to all Shared Databases, and Licensee’s use of the IDentify Application thereafter will be limited to use with the Licensee Databases only. Licensee acknowledges that Licensee’s right to access and use the Shared Databases is subject at all times to the participation by other Agencies in the Data Sharing Option on a continuous basis. If any Agency terminates its participation in the Data Sharing Option, Licensee will no longer

have access to the Shared Databases of such Agency or to any information generated from the Shared Databases associated with previously run searches and any resulting matches.

5. **Licensee Responsibilities.** Licensee shall be solely responsible for its use of the Shared Databases. Licensee represents and warrants that (a) it will use the Shared Databases solely in conjunction with its use of the IDentify Application in accordance with the terms of this Addendum, and (b) it will use the Shared Databases (including all data, content, materials, information and results contained in and/or generated from any of the foregoing) in compliance with all applicable laws, statutes, ordinances, rules, regulations, consent decrees, and/or requirements of any regulatory authority. Licensee shall defend, indemnify and hold harmless Veritone and its affiliates and licensors, and their respective members, officers, directors, employees, and agents, from and against any liability, losses, damages, judgments, costs and expenses, including litigation costs and reasonable attorneys' fees, arising out of or resulting from Licensee's use of the Shared Databases or Licensee's breach of any of its representations, warranties or obligations set forth in this Addendum.
6. **Authority.** The person executing this Addendum on behalf of each party represents and warrants that he or she has full authority to execute the same on behalf of such party, and that no other actions or approvals are required for such party to enter into this Addendum and perform its obligations hereunder.

IN WITNESS WHEREOF, the parties have caused this Addendum to be executed by their duly authorized representatives as of the date first above written.

VERITONE, INC.

Signature:

Name:

Title:

IRVINE POLICE DEPARTMENT

Signature:

Name:

Title:



LICENSE AGREEMENT

This License Agreement ("Agreement") is entered into as of the date of the last signature below ("Effective Date") by and between Veritone, Inc. (for itself and/or its subsidiaries), having a principal office located at 575 Anton Boulevard, Suite 100, Costa Mesa, CA 92626 ("Veritone") and the entity listed under Licensee Information below ("Licensee"), with respect to license(s) to Veritone's aiWARE Platform and related Services.

Table with sections: LICENSEE INFORMATION, LICENSE AND SERVICES DETAILS, and TERMS AND CONDITIONS. Includes fields for Agency Name, Address, Contact Info, Term, Users, Fees, and Services.

- 1. Master License Terms and Conditions. This Agreement and Licensee's access to and use of the Platform and Services shall be governed by the Veritone Master License Terms and Conditions attached hereto as Attachment A and incorporated herein by reference (the "Terms and Conditions").
2. Identify Application and Cognitive Processing. During the Term, Veritone will provide Licensee with access to the IDentify Application and the cognitive processing specified above for content uploaded to the Platform by Licensee through the IDentify Application.
3. Limitations. Licensee acknowledges that the IDentify Application is intended to be used by Licensee only as a tool to support review of digital evidence in connection with its investigations, and the IDentify Application and the results generated therefrom should not be considered or relied upon as a substitute for Licensee's customary investigative procedures, protocols and/or requirements.
4. Additional Services. Additional Services, such as on-site training, enhanced onboarding and/or support services, will be made available to Licensee for additional fees, which will be quoted by Veritone upon request.
5. Payment Terms. Veritone will submit an invoice to Licensee on a monthly basis for the License Fees due for the following month, and for any amounts incurred for additional Services performed during the previous month, and such invoices will be due and payable net thirty (30) days following the invoice date.

6. **Term and Termination.** Licensee may elect to terminate this Agreement at the expiration of the Trial Term specified above by providing thirty (30) days prior written notice to Veritone. Unless terminated at the expiration of the Trial Term or as otherwise provided herein, this Agreement will automatically continue following the Trial Term for the Initial Term specified above, and will automatically renew thereafter for successive one-year terms (each renewal term together with the Trial Term and Initial Term, collectively the "Term"). Following the Trial Term, either party may terminate this Agreement at any time, for any reason or no reason, by providing at least sixty (60) days prior written notice to the other party.
7. **Authority.** The person executing this Agreement on behalf of each party represents and warrants that he or she has full authority to execute the same on behalf of such party, and that no other actions or approvals are required for such party to enter into this Agreement and perform its obligations hereunder.

ACCEPTED AND AGREED BY:	
VERITONE, INC.	LICENSEE
Signature:	Signature:
Name:	Name:
Title:	Title:
Date:	Date:

ATTACHMENT A

**VERITONE, INC. MASTER LICENSE TERMS AND CONDITIONS
(PS-Rev 20180907)**

(Attached)

VERITONE, INC.

MASTER LICENSE TERMS AND CONDITIONS

These Master License Terms and Conditions (“Terms and Conditions”) apply to any License Agreement (as defined below) between Veritone, Inc. (or one of its subsidiaries) (“Veritone”) and a licensee (“Licensee”).

- 1. License Agreement; Controlling Terms.** For purposes hereof, “License Agreement” shall mean the written license agreement, or the order form, subscription form, statement of work or other document, including any addenda or exhibits thereto, accepted by Veritone in writing, that evidences the purchase of a license from Veritone by the Licensee (either directly or through an authorized reseller of Veritone) to access and use the Veritone aiWARE Platform (the “Platform”) and associated Services (as defined below). The Platform is an artificial intelligence operating system that delivers near real-time media processing and analytics, enabling users to process, index, organize, manage, search, analyze and share audio, video and other data through a suite of applications and other services (collectively, the “Services”). The specific Services, content, fees and payment terms, number of authorized users, and the term of license shall be as set forth in the License Agreement. The License Agreement may also contain other license-specific terms and conditions. The License Agreement and these Terms and Conditions are collectively referred to herein as this “Agreement.” In the event of any conflict or inconsistency among the terms and conditions set forth in the License Agreement and in these Terms and Conditions, the rights and obligations of the parties shall be interpreted based on the following order of priority: (1) the License Agreement and (2) these Terms and Conditions. This Agreement constitutes the complete and exclusive agreement between the parties with respect to the Platform and Services, superseding and replacing any and all prior agreements, communications, and understandings, both written and oral, regarding such subject matter, and no additional or different provision contained in any purchase order form, order acknowledgment form, invoice or similar form of either party will be effective.
- 2. License, Reservation of Rights, Restrictions.**
 - 2.1. License.** Veritone hereby grants to Licensee, during the Term (as defined in Section 7 below), a non-transferable, non-sublicensable, non-exclusive, revocable license to access and use the Platform and Services, subject to the terms and conditions set forth in this Agreement (the “License”). Licensee agrees to use the Platform and Services only for its internal business purposes in accordance with the terms of this Agreement. For the avoidance of doubt, the Platform and Services and its content may not be displayed publicly; provided that, subject to the provisions of Section 2.4 (Restrictions) and Section 11 (Indemnification) of this Agreement, Licensee may post, publish or otherwise share its owned or licensed content via the Platform for which sharing capabilities are enabled during the Term in accordance with the terms of this Agreement.
 - 2.2. Reservation of Rights.** The Platform and Services are licensed by Veritone to Licensee, and not sold. Licensee acquires only the right to use the Platform and Services in accordance with this Agreement and does not acquire any rights of ownership. Nothing herein shall be construed to transfer any rights, title or ownership of any Veritone or Veritone-licensed software, technology, materials, information or Intellectual Property Rights to Licensee. All right, title and interest (including all Intellectual Property Rights) in and to the Platform and Services shall at all times remain the sole and exclusive property of Veritone and/or its respective licensors and all use thereof shall inure to the benefit of Veritone and/or its respective licensors. Except as expressly set forth in this Agreement, no right or license, express or implied, is granted to Licensee or any third party by estoppel, implication, exhaustion or other doctrine of law, equity or otherwise with respect to any product, service, software, technology, materials, information or Intellectual Property Rights of Veritone or its affiliates or licensors. “**Intellectual Property Rights**” means all forms of proprietary rights, titles, interests, and ownership including patents, patent rights, copyrights, trademarks, trade dresses, trade secrets, know-how, mask works, *droit moral* (moral rights), publicity rights and all similar rights of every type that may exist now or in the future in any jurisdiction, including without limitation all applications and registrations therefore and rights to apply for any of the foregoing.
 - 2.3. Third Party Licenses.** Certain software components of the Platform and Services are supplied pursuant to license agreements from third parties, and Licensee agrees that Licensee’s use of the Platform and Services shall be subject to the provisions of such third party license agreements.
 - 2.4. Restrictions.**
 - 2.4.1. License Restrictions.** Licensee agrees to use the Platform and Services only for lawful purposes and only as expressly authorized under this Agreement. Without limiting the generality of the foregoing, except as expressly authorized hereunder, Licensee agrees that it shall not, directly or indirectly: (i) license, sublicense, sell, resell, rent, lease, transfer, assign, distribute, display or otherwise make the Platform or Services, in whole or in part, including any content or data derived therefrom that is not directly owned by Licensee or for which Licensee has

all necessary rights, available to any third party, or use the Platform or Services to provide services to any third party; (ii) reverse engineer, decompile, disassemble, modify, translate, reconstruct, omit, distort, obscure, copy or create derivative works of all or any portion of the Platform, Services, any underlying software, or any other Veritone Property (as defined below), or otherwise attempt to access the source code of the Platform or Services; (iii) incorporate any portion of the Platform or Services into Licensee's own programs or compile any portion of them in combination with Licensee's own programs; (iv) store or otherwise capture to physical media, or enable a third party to store or capture, the Platform or Services or any portion thereof; (v) permit any persons, other than Licensee's authorized users for which Licensee has procured User IDs pursuant to the License Agreement, to access and use the Platform or Services; (vi) upload or transmit through the Platform or Services any material, content, media or data (collectively, "Licensee Content") with respect to which Licensee does not either own all right, title and interest or have the appropriate license(s) for lawful use, or otherwise violate or infringe upon the intellectual property rights of any third party in Licensee's use of the Platform or Services, including the use or distribution of any data derived from the Platform or Services; or (vii) violate any laws, rules or regulations in connection with its use of the Platform or Services, including any data or content contained in, transmitted through or derived therefrom.

2.4.2. Prohibited Acts. Licensee acknowledges and agrees that Licensee is prohibited from doing any act that may have the effect of undermining the integrity of the Platform, Services, any related computer systems, infrastructure or environment, or the methods by which Veritone provides Services to users. Without limiting the generality of the foregoing, Licensee agrees that it shall not, directly or indirectly: (i) defeat, circumvent or modify any authentication technology or other security measures, controls, limitations, or content or functionality filters contained in or associated with the Platform or Services, or otherwise attempt to access any aspect of the Platform or Services that Licensee has not been granted authorization to access under the License Agreement; (ii) deploy or facilitate the use or deployment of any script, routine, robot, spider, scraper or any other automated means, method or device with respect to Licensee's access and use of the Platform and Services for any purpose, including to access, view, select, or copy in whole or in part, any content, program, functionality of the Platform or Services, or any other proprietary information or trade secret of Veritone that is made available through the Platform or Services; (iii) deploy or facilitate the use or deployment of any program, system, means, method or device, for any purpose that places an unreasonable, unnecessary or excessive demand or load on the Platform, Services, or related hardware and connections, or prohibits, denies or delays access to Services by other users or otherwise threatens the continuous services of Veritone's ISPs, suppliers and vendors; (iv) introduce into the Platform or Services any program, executable file or routine (such as a worm, Trojan horse, cancel-bot, time bomb or virus) irrespective of whether any such program or routine results in detrimental harm to the Platform, Services, or any underlying systems or programs; (v) remove any proprietary notices, labels or marks from the Platform or Services; (vi) establish any direct or deep link or other connection to any specific page or location within the Platform or Services, other than the Platform log-in page; (vii) use or attempt to use another user's account without authorization, or interfere with another user's access to the Platform or Services; or (viii) access or use the Platform or Services to design, develop, build, market or support a competitive product or service.

3. Access and Use. Veritone will enable Licensee to access and use the Platform for the duration of the Term, subject to any early termination of this Agreement in accordance with the terms hereof. Access to the Platform will be through unique log-in credentials assigned to Licensee by Veritone (each, a "User ID"). Licensee shall be given that number of User IDs as specified in the License Agreement. Licensee will provide accurate and complete information in registering its authorized users for account access. Licensee acknowledges and agrees that the log-in credentials assigned hereunder are Confidential Information and may only be used by Licensee and its authorized users to access the Platform in accordance with the terms of this Agreement, and that Licensee will not publish, share, or otherwise enable any third party, directly or indirectly, to access the Platform for any purpose. Licensee further agrees that Licensee is responsible for its and its authorized users' use of the Platform, including use via the User IDs, and for any consequences thereof. Licensee agrees to immediately notify Veritone of any unauthorized or improper use of any log-in credentials of Licensee. All of the rights, obligations, restrictions, representations and warranties related to Licensee's access and use of the Platform under this Agreement shall apply to Licensee and all of Licensee's employees, contractors, consultants, representatives and agents (collectively, "Representatives"). Licensee shall be responsible for all acts and omissions of its Representatives in the performance of this Agreement and for any breach of this Agreement by any of its Representatives.

4. Intellectual Property.

4.1. Veritone Property. As between Veritone and Licensee, Veritone and/or its respective licensors retain all right, title and interest (including Intellectual Property Rights) in and to the Platform and Services, including, but not limited to any

elements, components, content, technology, software, code, documentation, derivative works, revisions, enhancements, modifications, condensations and/or compilations of or relating to the Platform and Services, and any trademarks, brand identifiers, materials and information, which are created, authored, developed, conceived and/or reduced to practice by Veritone and/or its respective licensors, including in connection with Veritone's provision of the Platform and Services to Licensee under this Agreement ("**Veritone Property**").

4.2. Licensee Property. As between Licensee and Veritone, Licensee retains all right, title and interest (including Intellectual Property Rights) in and to the Licensee Content, and any software, technology, trademarks, brand identifiers, materials and information which are independently created, authored, developed, conceived or reduced to practice by Licensee.

5. Licensee Content.

5.1. Content Ownership. Licensee represents and warrants that (i) Licensee and/or its licensors own all right, title and interest in and to all Licensee Content uploaded to or transmitted through the Platform or Services, or otherwise have all rights in such Licensee Content as necessary to use the same in connection with Licensee's use of the Platform and Services, (ii) such Licensee Content does not and will not misappropriate or infringe upon any third party's Intellectual Property Rights, or violate any other rights of any third party, and (iii) Licensee has all rights in such Licensee Content necessary to grant the rights contemplated by this Agreement.

5.2. License to Content. Unless otherwise specified in the License Agreement, Licensee hereby grants to Veritone a non-exclusive, royalty-free, worldwide license (i) to use and display all Licensee Content that Licensee provides to Veritone or that are otherwise uploaded to or captured by the Platform through Licensee's use of the Platform and Services to provide the Services and perform its obligations under this Agreement, directly or through its third party service providers, and (ii) to share such Licensee Content with Veritone's third party service providers solely as required for Veritone's provision of the Platform and Services to Licensee.

5.3. Data Security and Destruction. Veritone will maintain and use adequate administrative, physical, and technical safeguards for protection of the security, confidentiality and integrity of all Licensee Content uploaded to or transmitted through the Platform or Services. Licensee Content shall be used and stored by Veritone solely to the extent required to provide the Services and perform its obligations under this Agreement or as otherwise expressly provided in the License Agreement, and Veritone shall not use or store the Licensee Content for any other purpose whatsoever. Upon termination of this Agreement or upon the written request of Licensee at any time, Veritone shall ensure the secure deletion and destruction of all Licensee Content.

6. Feedback. During the Term, Licensee may provide Veritone with such written evaluations, comments and/or suggestions (collectively, "**Feedback**") regarding the Platform or Services. Licensee acknowledges and agrees that any Feedback provided to Veritone by Licensee hereunder shall be deemed to be Veritone Property and Licensee hereby assigns all right, title and interest in and to such Feedback to Veritone and acknowledges that Veritone will be entitled to, without limitation, implement and exploit any such Feedback in any manner without any restriction or obligation. Notwithstanding the foregoing, Licensee acknowledges that Veritone is not obligated to act on any such Feedback.

7. Term and Termination.

7.1. Term. The term of this Agreement and the License shall be as set forth in the License Agreement (the "**Term**").

7.2. Termination. In addition to any termination rights expressly provided in the License Agreement, this Agreement may be terminated by either party if the other party (i) materially breaches any provision of this Agreement which remains uncured for a period of fourteen (14) days from the date of written notice of such breach; or (ii) makes an assignment for the benefit of its creditors, is declared insolvent, or has a receiver or trustee in bankruptcy appointed to take charge of all or part of such party's property.

7.3. Effect of Termination. If at any time this Agreement is terminated, or upon expiration of the Term, the License and all other rights granted to Licensee herein shall automatically terminate and Licensee shall immediately cease using the Platform and Services.

7.4. Survival. The provisions of Sections 2.2 (Reservation of Rights), 4 (Intellectual Property), 6 (Feedback), 7.3 (Effect of Termination), 8.1 (Fees and Payments), 8.2 (Taxes), 10 (Confidentiality), 11 (Indemnification), 12.2 and 12.3 (Warranty and Disclaimers), 13 (Limitation of Liability), 14 (Miscellaneous) hereof and the payment terms of License Agreement, as applicable, shall survive the expiration or any early termination of this Agreement for any reason.

8. Fees, Charges and Payments.

8.1. Fees and Payments. In consideration for the License and Licensee's access and use of the Platform and Services, Licensee shall pay the license fees, and any applicable additional fees, as set forth in the License Agreement (collectively, the "Fees"). All Fees and other amounts due under this Agreement are payable in U.S. dollars.

8.2. Taxes. All Fees and any other amounts due hereunder are exclusive of taxes and similar assessments which may be imposed on the delivery of the Platform and Services and any other transactions contemplated hereby. Licensee shall be solely responsible for the payment of any and all sales, use, value added, excise, import, or other similar taxes or payments in lieu thereof, including interest and penalties thereon, imposed by any authority, government or governmental agency arising out of or in connection with amounts due hereunder (other than those levied on Veritone's income), and Licensee shall make such payments, and timely file any return or information required by treaty, law, rule or regulation. Upon request, Licensee shall provide Veritone with documentation evidencing such payments. If Veritone is required to pay any such taxes, duties or fees, Licensee shall reimburse Veritone immediately upon receipt of Veritone's invoice thereof.

8.3. Suspension of Platform Access. In addition to Veritone's termination rights set forth herein and without prejudice to any other rights of Veritone at law or in equity, Veritone may suspend its performance under this Agreement and any other agreement with Licensee and Licensee's access to the Platform if Licensee fails to comply with any part of its payment obligations set forth herein. Such suspension of service shall not suspend or otherwise affect Licensee's payment obligations set forth herein.

9. Changes to Platform, Service and Fees. Veritone may, from time to time, in its sole discretion, make changes to the Platform and Services, or a portion thereof including, without limitation, formats, content, reports, functionality, and/or techniques ("Service Change"). In the event of a Service Change, Veritone may, adjust the Fees for the Platform and Services ("Fee Change") in writing. Such Fee Change shall become effective on the date stated in Veritone's notice to Licensee unless, within fifteen (15) days after a Fee Change notice that would result in an increase in the Fees, Licensee notifies Veritone in writing of its refusal to accept the Fee Change, in which event the applicable License to Licensee shall terminate as of the effective date of the change; provided, however, that if the Fee Change is an increase in the Fees, Veritone may, in its sole discretion, elect to rescind the Fee Change, in which case the Platform and Services, as changed, shall continue as provided herein.

10. Confidentiality.

10.1. Confidential Information. Each party (a receiving party) acknowledges and agrees that during the Term and in the course of using the Platform and Services and performing its duties under this Agreement, it may obtain information relating to the other party (a disclosing party), its and/or its customers', vendors', or third party service providers' business or technologies, which is of a confidential and proprietary nature ("**Confidential Information**"). Such Confidential Information may include, but is not limited to, trade secrets, know-how, inventions, techniques, processes, software, algorithms, programs, schematics, data, technology roadmap, sales and marketing plans, and any other information which the receiving party knows or has reason to know is, or which by its nature would reasonably be considered to be, confidential, proprietary or trade secret information of the other party. Without limiting the foregoing, Confidential Information of Veritone shall include the Platform, Services and all associated software and documentation, as well as Feedback or any results of the evaluation or testing of the Platform or Services. The receiving party shall at all times, both during the Term and for a period of three (3) years after its termination (or, in the case of the Platform, Services and any associated software or trade secrets, in perpetuity), keep in trust and confidence all Confidential Information of the disclosing party, and shall not (i) use such Confidential Information other than as expressly authorized under this Agreement or as required for the receiving party to perform its obligations under this Agreement, or (ii) disclose any Confidential Information of the disclosing party to third parties (other than to Veritone's third party service providers in connection with the performance of its obligations under this Agreement), without the disclosing party's prior written consent. The receiving party further agrees to immediately return to the disclosing party or destroy all Confidential Information (including all copies, extracts and summaries thereof) in the receiving party's possession, custody, or control upon the expiration or any termination of this Agreement. The obligations of confidentiality shall not apply to information which (a) has entered the public domain except where such entry is the result of the receiving party's breach of this Agreement; (b) prior to disclosure hereunder, was already in the receiving party's possession and not subject to any confidentiality obligations, as demonstrated by written evidence; (c) subsequent to disclosure hereunder is obtained by the receiving party on a non-confidential basis from a third party who has the right to disclose such information to the receiving party; or (d) has been independently developed by the receiving party without use of or reference to the disclosing party's Confidential Information, as demonstrated by written evidence.

10.2. Permitted Disclosures. The receiving party may make disclosures (i) as required by applicable law or the rules of a stock exchange on which such party's shares are then traded; or (ii) as compelled by court order issued by a court of competent

jurisdiction provided that the receiving party subject to such court order (a) provides the disclosing party with prompt written notice of any such compelled disclosure, (b) uses diligent reasonable efforts to limit disclosure, (c) uses commercially reasonable efforts to obtain confidential treatment or a protective order in connection with the information subject to such compelled disclosure, and (d) allows the disclosing party to participate in any such proceeding.

11. Indemnification.

11.1. Licensee Indemnification of Veritone. Licensee will defend, indemnify and hold harmless Veritone and its subsidiaries, affiliates, successors, assigns, licensors, and their respective members, officers, directors, employees, licensors, agents, from and against any liability or expense, including, without limitation, any expenses, losses, damages, judgments, litigation costs and reasonable attorneys' fees, that Veritone may incur as a result of any claim, suit or proceeding brought against Veritone by any third party arising or resulting from (a) Licensee's breach of any representation, warranty, covenant or obligation contained in this Agreement; or (b) Licensee's use of the Platform or Services (including uploading, using, publishing, posting or otherwise sharing of Licensee's Content or any other data or content derived from the Platform or Services) in any manner that violates this Agreement or any laws, rules, regulations or third party terms and conditions, or that misappropriates or infringes the rights (including Intellectual Property Rights) of any third party; *provided that* Veritone gives Licensee prompt notice of any such claims, cooperates with Licensee in responding to such claims, and permits Licensee to control the defense or settlement of such claims, subject to Veritone's right to (i) conduct the defense of such claims at Veritone's expense, or participate in the defense of such claims with its own counsel at its own expense, and (ii) approve any settlement that binds or purports to bind Veritone.

11.2. Veritone Indemnification of Licensee. Veritone will defend, indemnify and hold harmless Licensee and its subsidiaries, affiliates, successors, assigns, licensors, and their respective members, officers, directors, employees, licensors, agents, from and against any liability or expense, including without limitation, any expenses, losses, damages, judgments, litigation costs and reasonable attorneys' fees that Licensee may incur as a result of any claim, suit or proceeding brought against Licensee by any third party arising or resulting from (a) Veritone's breach of any representation, warranty, covenant or obligation contained in this Agreement; or (b) any allegation that the Platform or Services, or any part thereof, misappropriates or infringes upon any third party's Intellectual Property Rights, except to the extent such claims arise from Licensee's negligence, misconduct or violation of any terms of this Agreement; *provided that* Licensee gives Veritone prompt notice of any such claims, cooperates with Veritone in responding to such claims, and permits Veritone to control the defense or settlement of such claims, subject to Licensee's right to (i) conduct the defense of such claims at Licensee's expense, or participate in the defense of such claims with its own counsel at its own expense, and (ii) approve any settlement that binds or purports to bind Licensee. If the Platform, in whole in part, becomes or, in Veritone's opinion is likely to become, the subject of an infringement claim or action, Veritone may, at its option: (x) procure, at no cost to Licensee, the right for Licensee to continue using the Platform; (y) replace or modify the Platform to render the Platform non-infringing, provided there is no material loss of functionality; or (z) if, in Veritone's reasonable opinion, neither (x) nor (y) above is commercially feasible, terminate this Agreement and refund any prepaid amounts for unused Services during the terminated portion of the Term. The foregoing states Veritone's sole obligation and Licensee's exclusive remedy in the event any such infringement claim or action is commenced or is likely to be commenced.

12. Warranties and Disclaimers.

12.1. Mutual Warranties. Each party represents and warrants to the other that: (i) it is duly organized and validly existing under the laws of the jurisdiction of its incorporation or formation, and has full power, rights and authority to enter into this Agreement and carry out its obligations hereunder; (ii) the person executing this Agreement is authorized to do so on its behalf; (iii) this Agreement is valid and legally binding upon it and (iv) the execution, delivery and performance thereof by such party does not conflict with any other agreement, instrument or understanding to which it is a party or by which it may be bound, nor would violate any applicable law or regulation.

12.2. Disclaimer. THE PLATFORM, SERVICES AND ANY OTHER VERITONE PRODUCTS AND SERVICES ARE PROVIDED ON AN "AS IS" AND "AS AVAILABLE" BASIS. EXCEPT AS EXPRESSLY PROVIDED IN THIS AGREEMENT, VERITONE MAKES NO WARRANTY, EXPRESS OR IMPLIED, WITH RESPECT TO THE PLATFORM AND SERVICES, INCLUDING, WITHOUT LIMITATION, ANY WARRANTY AS TO THE ACCURACY OF PROCESSING RESULTS, ANY WARRANTY OF MERCHANTABILITY, QUALITY OR FITNESS FOR A PARTICULAR PURPOSE, WARRANTIES ARISING FROM COURSE OF DEALING OR USAGE OF TRADE, AND WARRANTIES OF NON-INFRINGEMENT. VERITONE DOES NOT WARRANT THAT THE PLATFORM AND SERVICES ARE ERROR-FREE, WILL RUN UNINTERRUPTED, OR THAT ALL ERRORS CAN OR WILL BE CORRECTED. NO ADVICE OR INFORMATION, WHETHER ORAL OR WRITTEN, OBTAINED BY LICENSEE FROM VERITONE SHALL CREATE ANY SUCH WARRANTY.

12.3. LICENSEE ACKNOWLEDGES AND AGREES THAT THE INTERNET IS A PUBLIC NETWORK OVER WHICH VERITONE EXERTS NO CONTROL. VERITONE MAKES NO REPRESENTATIONS OR WARRANTIES WHATSOEVER, AND SHALL HAVE NO LIABILITY WHATSOEVER, WITH RESPECT TO THE ACCURACY, DEPENDABILITY, PRIVACY, SECURITY, AUTHENTICITY OR COMPLETENESS OF DATA TRANSMITTED OVER OR OBTAINED USING THE INTERNET OUTSIDE OF THOSE SYSTEMS AND NETWORKS CONTROLLED BY VERITONE, OR ANY INTRUSION, VIRUS, DISRUPTION, LOSS OF COMMUNICATION, LOSS OR CORRUPTION OF DATA, OR OTHER ERROR OR EVENT CAUSED OR PERMITTED BY OR INTRODUCED THROUGH LICENSEE'S OWN USE OF THE INTERNET. LICENSEE IS SOLELY RESPONSIBLE FOR IMPLEMENTING ADEQUATE FIREWALL, PASSWORD AND OTHER SECURITY MEASURES TO PROTECT ITS SYSTEMS, DATA AND APPLICATIONS FROM UNWANTED INTRUSION, WHETHER OVER THE INTERNET OR BY OTHER MEANS.

13. Limitation of Liability.

13.1. EXCEPT FOR (A) BREACHES OF EACH PARTY'S OBLIGATIONS UNDER SECTION 10 (CONFIDENTIALITY), AND (B) AMOUNTS FINALLY AWARDED OR SETTLED IN A THIRD PARTY CLAIM FOR WHICH A PARTY IS RESPONSIBLE UNDER SECTION 11 (INDEMNIFICATION), NEITHER PARTY, INCLUDING ITS OFFICERS, DIRECTORS, EMPLOYEES, REPRESENTATIVES AND AFFILIATES, SHALL BE LIABLE FOR ANY INDIRECT, INCIDENTAL, SPECIAL, CONSEQUENTIAL, OR PUNITIVE DAMAGES, INCLUDING WITHOUT LIMITATION, LOST DATA OR LOST PROFITS, OR COSTS OF PROCURING SUBSTITUTE GOODS OR SERVICES, HOWEVER ARISING, EVEN IF IT HAS BEEN ADVISED OF THE POSSIBILITY OF SUCH DAMAGES.

13.2. EXCEPT WITH RESPECT TO EACH PARTY'S CONFIDENTIALITY AND INDEMNIFICATION OBLIGATIONS HEREUNDER, NEITHER PARTY'S LIABILITY FOR DAMAGES ARISING OUT OF, RELATING TO OR IN ANY WAY CONNECTED WITH THIS AGREEMENT SHALL EXCEED THE TOTAL FEES PAID BY LICENSEE TO VERITONE UNDER THIS AGREEMENT.

14. MISCELLANEOUS

14.1. No Assignment. Neither party may assign any of its rights or obligations under this Agreement without the prior written consent of the other party, except that either party may assign its rights and obligations under this Agreement without the consent of the other party to an affiliate directly or indirectly controlling, controlled by, or under direct or indirect common control with such party or in connection with any merger (by operation of law or otherwise), consolidation, reorganization, change in control or sale of all or substantially all of its assets related to this Agreement or similar transaction. This Agreement inures to the benefit of and shall be binding on the parties' permitted assignees, transferees and successors.

14.2. Severability. If any provision of this Agreement is found by a court of competent jurisdiction to be invalid, the parties nevertheless agree that the court should endeavor to give effect to the parties' intentions as reflected in such provision, and the other provisions of this Agreement remain in full force and effect.

14.3. No Waiver. The failure of either party to exercise or enforce any right or provision of this Agreement shall not constitute a waiver of such right or provision.

14.4. Controlling Law. This Agreement shall be governed by and construed in accordance with the laws of the State of California (other than the conflict of law rules) and subject to the sole jurisdiction of the courts sitting in Orange County, California. Notwithstanding the foregoing, nothing in this Section 14.4 shall be deemed to limit the parties' rights to seek injunctive relief in any other court of law of competent jurisdiction.

14.5. Independent Contractors. This Agreement does not create any relationship other than Veritone as an independent contractor performing services covered by this Agreement and Licensee as the party contracting with Veritone for those services. No party is a partner or a legal representative of the other for any purpose whatsoever, nor is any party authorized to make any contract, agreement or warranty on behalf of any other party. Under no circumstance shall one party's employees be construed to be employees of the other party.

14.6. Publicity. Except as required or compelled by applicable law, the rules of any stock exchange, or a court order issued by a court of competent jurisdiction, neither party will make any public statement regarding, or disclose, advertise or publish the terms and conditions of this Agreement without the prior written consent of the other party; provided, however, that Veritone may reference Licensee on Veritone's website, other marketing materials, investor relations materials, and as a customer in Veritone's SEC filings.

14.7. Notices. All notices to either party shall be in writing and delivered by hand or by certified mail or overnight delivery service to the address set forth by Licensee and/or Veritone in the License Agreement, or to such other address as either party shall provide by notice to the other party. Alternatively, the parties may, at their election, utilize email as the method of delivery of any such notice to be provided hereunder. Any such notices sent by email shall be delivered to the email addresses set forth in the License Agreement, or such other email address as designed by a party during the Term. Notices shall be deemed effective when delivered to the applicable address, unless any such notice is sent by

email, in which event, notice shall be deemed effective upon confirmation of delivery by a “read receipt” or other such notice generated by the applicable email system, but in any event, by reply of the recipient of such notice.

- 14.8. Electronic Communication.** In connection with its use of the Platform and Services, Licensee consents to receiving communications from Veritone electronically. Veritone will communicate with Licensee by e-mail or by posting notices on the Platform or through any Services. Licensee agrees that all notices, disclosures and other communications that Veritone provides to Licensee electronically satisfy any legal requirement that such communications be in writing.
- 14.9. Force Majeure.** Except for the obligation to make payments of any Fees or any other amounts due hereunder, neither party will be liable for any failure or delay in its performance under the Agreement due to any cause beyond such party’s control including acts of war, terrorism, acts of God, embargo, riot, sabotage, labor shortage or dispute, governmental act, or failure of the Internet, or any component comprising or operating the network infrastructure thereof (each, a “**Force Majeure Event**”), provided that the delayed party: (i) gives the other party prompt notice of such cause, and (ii) uses its reasonable commercial efforts to promptly correct such failure or delay in performance. If Veritone is unable to provide Service(s) for a period of sixty (60) consecutive days as a result of a continuing Force Majeure Event, either party may elect to terminate this Agreement.
- 14.10. Construction.** This Agreement shall be fairly interpreted and construed in accordance with its terms and without strict interpretation or construction in favor of or against either party. Each party has had the opportunity to consult with counsel in the negotiation of this Agreement.
- 14.11. Counterparts.** This Agreement may be executed in one or more counterparts (including fax or email) each of which shall be deemed an original but all of which taken together shall be deemed one and the same instrument.
- 14.12. Headings.** Unless otherwise expressly stated in this Agreement, the words “herein,” “hereof,” “hereto,” and “hereunder” and other words of similar import refer to this Agreement as a whole and not to any particular section, subsection, or other subdivision. The words “include” and “including” shall not be construed or interpreted as terms of limitation. The words “day,” “month,” and “year” mean, respectively, calendar day, calendar month, and calendar year. Section headings are for reference purposes only, and should not be used in the interpretation hereof.
- 14.13. Amendment.** No addendum, waiver, consent, modification, amendment or change of the terms of this Agreement shall bind either party unless in a writing that references this Agreement and is signed by duly authorized representatives of Licensee and Veritone.
- 14.14. Attorney’s Fees.** If any action arises under this Agreement, including, without limitation the interpretation or enforcement of any term of this Agreement, the prevailing party in any such action shall be entitled to recover its reasonable attorney’s fees and related costs.

From: Noelle Smiley
Sent: Thursday, January 31, 2019 10:32 AM PST
To: Mark Anderson
Subject: Re: Veritone pilot agreement

Thank you. Let me run this agreement by a couple people before we move forward. Thanks.

Sent from my iPhone

On Jan 31, 2019, at 8:31 AM, Mark Anderson <manderson@cityofirvine.org> wrote:

Commander,

Reference the demo for the facial recognition software; we would like to move forward with the T & E trial period with the program. This is a free trial period for 90 days. Bill highlighted the details below. Please let me know if you need more info. If we do move forward with the purchase, the cost is \$20K/year.

Thank you,

Mark

From: William Hillyard
Sent: Thursday, January 31, 2019 8:13 AM
To: Mark Anderson <manderson@cityofirvine.org>
Subject: FW: Veritone pilot agreement

LT,

Attached are the documents for the Pilot Program agreement with Veritone that need Chief Hamel's signature. Here are some brief points regarding the agreements:

- Irvine PD can opt out of the data sharing portion of the software at any time. If we did opt out but continued to use the software the suspect photos would only be compared to our database of known offenders, and no other agencies would have access to our database of booking photos and known offenders.
- The free trial period for the Pilot Program is 90 days, not 60 as was discussed during our meeting with Veritone.
- The initial License Agreement states that we will have (5) user profiles. This is only for the term of the Pilot Program. If we go forward with purchasing the software we will have an unlimited number of user licenses.

- Section 5.3 of the Master License Terms and Conditions states that if we cancel our relationship with Veritone any data we have provided them is removed from their servers and deleted. There are several portions throughout the agreements which clearly spell out that the data provided by Irvine PD remains the property of Irvine PD and should we terminated our contract with them they have no rights to retain or continue to use any data we provided them.
- The data we are providing other agencies access to through Veritone is no different than the data we upload to Coplink on a daily basis.
- For the Pilot Program we will provide Veritone with an initial data dump of our current database of booking photos, if we go forward with purchasing the software Veritone can set up and automated upload of new booking photos so there is no additional workload for our personnel.

I spoke with Nick Rycroft Monday reference the IT portion of it and he stated when the agreement is signed by the Chief he would begin working on the data export as requested by Veritone.

Please let me know if can provide any additional information.

Thank you,

Bill Hillyard

Begin forwarded message:

From: Tom Avery <tavery@veritone.com>
Date: January 30, 2019 at 7:15:09 AM PST
To: William Hillyard <whillyard@cityofirvine.org>
Subject: Veritone pilot agreement

Bill,

Attached is the Veritone pilot agreement documents which also include the terms and conditions as well as the data sharing agreement. Let me know if you have any questions.

Thanks,
Tom

Tom Avery
Vice President Public Safety

Veritone Government
tavery@veritone.com

Privacy [REDACTED] cell

<image001.png>

Veritone, Inc. 575 Anton Blvd. Suite 100, Costa Mesa CA. 92626
www.veritone.com

<Irvine PD Data Sharing Addendum (20190128).docx>

<Irvine Police Department License Agreement (IDentify) (20190128).docx>

<Master License Terms and Conditions (PS Rev 20180907).pdf>

<image001.png>

From: Noelle Smiley
Sent: Monday, February 4, 2019 9:43 AM PST
To: Mark Anderson
Subject: RE: Veritone pilot agreement

So in looking at these documents the licensing agreement reads that it will cost "\$15,000 per month." That doesn't sound right to me based on the meeting we had with them.

From: Mark Anderson
Sent: Thursday, January 31, 2019 8:32 AM
To: Noelle Smiley <nsmiley@cityofirvine.org>
Subject: FW: Veritone pilot agreement

Commander,

Reference the demo for the facial recognition software; we would like to move forward with the T & E trial period with the program. This is a free trial period for 90 days. Bill highlighted the details below. Please let me know if you need more info. If we do move forward with the purchase, the cost is \$20K/year.

Thank you,

Mark

From: William Hillyard
Sent: Thursday, January 31, 2019 8:13 AM
To: Mark Anderson <manderson@cityofirvine.org>
Subject: FW: Veritone pilot agreement

LT,

Attached are the documents for the Pilot Program agreement with Veritone that need Chief Hamel's signature. Here are some brief points regarding the agreements:

- Irvine PD can opt out of the data sharing portion of the software at any time. If we did opt out but continued to use the software the suspect photos would only be compared to our database of known offenders, and no other agencies would have access to our database of booking photos and known offenders.
- The free trial period for the Pilot Program is 90 days, not 60 as was discussed during our meeting with Veritone.
- The initial License Agreement states that we will have (5) user profiles. This is only for the term of the Pilot Program. If we go forward with purchasing the software we will have an unlimited number of user licenses.

- Section 5.3 of the Master License Terms and Conditions states that if we cancel our relationship with Veritone any data we have provided them is removed from their servers and deleted. There are several portions throughout the agreements which clearly spell out that the data provided by Irvine PD remains the property of Irvine PD and should we terminated our contract with them they have no rights to retain or continue to use any data we provided them.
- The data we are providing other agencies access to through Veritone is no different than the data we upload to Coplink on a daily basis.
- For the Pilot Program we will provide Veritone with an initial data dump of our current database of booking photos, if we go forward with purchasing the software Veritone can set up and automated upload of new booking photos so there is no additional workload for our personnel.

I spoke with Nick Rycroft Monday reference the IT portion of it and he stated when the agreement is signed by the Chief he would begin working on the data export as requested by Veritone.

Please let me know if can provide any additional information.

Thank you,

Bill Hillyard

Begin forwarded message:

From: Tom Avery <tavery@veritone.com>
Date: January 30, 2019 at 7:15:09 AM PST
To: William Hillyard <whillyard@cityofirvine.org>
Subject: Veritone pilot agreement

Bill,

Attached is the Veritone pilot agreement documents which also include the terms and conditions as well as the data sharing agreement. Let me know if you have any questions.

Thanks,
Tom

Tom Avery
Vice President Public Safety

Veritone Government
tavery@veritone.com
Privacy [REDACTED] cell

From: Mark Anderson
Sent: Monday, February 4, 2019 1:34 PM PST
To: Noelle Smiley
Subject: RE: Veritone pilot agreement

It'll be 20K.

From: Noelle Smiley
Sent: Monday, February 4, 2019 9:44 AM
To: Mark Anderson <manderson@cityofirvine.org>
Subject: RE: Veritone pilot agreement

So in looking at these documents the licensing agreement reads that it will cost "\$15,000 per month." That doesn't sound right to me based on the meeting we had with them.

From: Mark Anderson
Sent: Thursday, January 31, 2019 8:32 AM
To: Noelle Smiley <nsmiley@cityofirvine.org>
Subject: FW: Veritone pilot agreement

Commander,

Reference the demo for the facial recognition software; we would like to move forward with the T & E trial period with the program. This is a free trial period for 90 days. Bill highlighted the details below. Please let me know if you need more info. If we do move forward with the purchase, the cost is \$20K/year.

Thank you,

Mark

From: William Hillyard
Sent: Thursday, January 31, 2019 8:13 AM
To: Mark Anderson <manderson@cityofirvine.org>
Subject: FW: Veritone pilot agreement

LT,

Attached are the documents for the Pilot Program agreement with Veritone that need Chief Hamel's signature. Here are some brief points regarding the agreements:

- Irvine PD can opt out of the data sharing portion of the software at any time. If we did opt out but continued to use the software the suspect photos would only be compared to our database of known offenders, and no other agencies would have access to our database of booking photos and known offenders.

- The free trial period for the Pilot Program is 90 days, not 60 as was discussed during our meeting with Veritone.
- The initial License Agreement states that we will have (5) user profiles. This is only for the term of the Pilot Program. If we go forward with purchasing the software we will have an unlimited number of user licenses.
- Section 5.3 of the Master License Terms and Conditions states that if we cancel our relationship with Veritone any data we have provided them is removed from their servers and deleted. There are several portions throughout the agreements which clearly spell out that the data provided by Irvine PD remains the property of Irvine PD and should we terminated our contract with them they have no rights to retain or continue to use any data we provided them.
- The data we are providing other agencies access to through Veritone is no different than the data we upload to Coplink on a daily basis.
- For the Pilot Program we will provide Veritone with an initial data dump of our current database of booking photos, if we go forward with purchasing the software Veritone can set up and automated upload of new booking photos so there is no additional workload for our personnel.

I spoke with Nick Rycroft Monday reference the IT portion of it and he stated when the agreement is signed by the Chief he would begin working on the data export as requested by Veritone.

Please let me know if can provide any additional information.

Thank you,

Bill Hillyard

Begin forwarded message:

From: Tom Avery <tavery@veritone.com>
Date: January 30, 2019 at 7:15:09 AM PST
To: William Hillyard <whillyard@cityofirvine.org>
Subject: Veritone pilot agreement

Bill,

Attached is the Veritone pilot agreement documents which also include the terms and conditions as well as the data sharing agreement. Let me know if you have any questions.

Thanks,
Tom

Tom Avery
Vice President Public Safety
Veritone Government
tavery@veritone.com
Privacy [REDACTED] cell

From: Mark Anderson
Sent: Monday, February 4, 2019 2:17 PM PST
To: William Hillyard
Subject: FW: Veritone pilot agreement
Attachments: image001.png, ATT00001.htm, Irvine PD Data Sharing Addendum (20190128).docx, ATT00002.htm, Irvine Police Department License Agreement (IDentify) (20190128).docx, ATT00003.htm, Master License Terms and Conditions (PS Rev 20180907).pdf, ATT00004.htm, image001.png, ATT00005.htm

Hi Sir. In the License Agreement attached it talked about 15,000 per month, but it's waived? Just not clear what that means. Can you take and look at it and explain or reach out to Veritone and ask for an explanation. Thank you

From: William Hillyard
Sent: Thursday, January 31, 2019 8:13 AM
To: Mark Anderson <manderson@cityofirvine.org>
Subject: FW: Veritone pilot agreement

LT,

Attached are the documents for the Pilot Program agreement with Veritone that need Chief Hamel's signature. Here are some brief points regarding the agreements:

- Irvine PD can opt out of the data sharing portion of the software at any time. If we did opt out but continued to use the software the suspect photos would only be compared to our database of known offenders, and no other agencies would have access to our database of booking photos and known offenders.
- The free trial period for the Pilot Program is 90 days, not 60 as was discussed during our meeting with Veritone.
- The initial License Agreement states that we will have (5) user profiles. This is only for the term of the Pilot Program. If we go forward with purchasing the software we will have an unlimited number of user licenses.
- Section 5.3 of the Master License Terms and Conditions states that if we cancel our relationship with Veritone any data we have provided them is removed from their servers and deleted. There are several portions throughout the agreements which clearly spell out that the data provided by Irvine PD remains the property of Irvine PD and should we terminated our contract with them they have no rights to retain or continue to use any data we provided them.
- The data we are providing other agencies access to through Veritone is no different than the data we upload to Coplink on a daily basis.
- For the Pilot Program we will provide Veritone with an initial data dump of our current database of booking photos, if we go forward with purchasing the software Veritone can set

up and automated upload of new booking photos so there is no additional workload for our personnel.

I spoke with Nick Rycroft Monday reference the IT portion of it and he stated when the agreement is signed by the Chief he would begin working on the data export as requested by Veritone.

Please let me know if can provide any additional information.

Thank you,

Bill Hillyard

Begin forwarded message:

From: Tom Avery <tavery@veritone.com>
Date: January 30, 2019 at 7:15:09 AM PST
To: William Hillyard <whillyard@cityofirvine.org>
Subject: Veritone pilot agreement

Bill,

Attached is the Veritone pilot agreement documents which also include the terms and conditions as well as the data sharing agreement. Let me know if you have any questions.

Thanks,
Tom

Tom Avery
Vice President Public Safety
Veritone Government
tavery@veritone.com
Privacy [REDACTED] cell

**Veritone IDentify Application
Data Sharing Addendum**

This Data Sharing Addendum (“Addendum”) is entered into as of February __, 2019, by and between Veritone, Inc. (“Veritone”) and Irvine Police Department (“Licensee”). This Addendum is incorporated by reference into, made a part of and governed by the terms of the License Agreement dated February __, 2019 between Veritone and Licensee (the “Agreement”). In the event of any conflict or inconsistency between the provisions contained in the Agreement and the provisions contained in this Addendum with respect to the subject matter hereof, the provisions of this Addendum shall govern and control. Capitalized terms used but not defined herein shall have the meanings ascribed to them in the Agreement.

1. **IDentify Application.** Veritone has granted to Licensee a right and license to access and use the IDentify Application within the Platform. The IDentify Application allows users to upload booking, arrest and known offender databases (collectively, “Booking Databases”) and use facial recognition technology to compare digital evidence from crime scenes with the Booking Databases to identify potential suspects. The IDentify Application also allows Licensee and other judicial and law enforcement agencies (each, an “Agency”) to elect to share access to their Booking Databases as further described in this Addendum (the “Data Sharing Option”).
2. **Participation in Data Sharing Option.** By executing this Addendum, Licensee hereby elects to participate in the Data Sharing Option, and each of Licensee and Veritone acknowledges and agrees to the supplemental terms and conditions applicable to the Data Sharing Option as set forth in this Addendum, in addition to the terms of the Agreement. All rights granted by each party under this Addendum shall continue during the Term of the Agreement, unless earlier terminated as set forth herein.
3. **Databases.**
 - (a) **Shared Databases.** Licensee will participate in the Data Sharing Option with respect to the Booking Databases indicated below (the option indicated below referred to hereinafter as the “Shared Databases”) (*check/complete one option*):
 - The Booking Databases maintained in the Platform by all other Agencies participating in the Data Sharing Option; or
 - The Booking Databases maintained in the Platform by the following Agencies:
 1. N/A
 - 2.
 - 3.
 - 4.
 - (b) **Access to Licensee Databases.** Licensee hereby grants to Veritone the right to grant access to all Booking Databases that Licensee maintains in the Platform (the “Licensee Databases”) to each other Agency that is participating in the Data Sharing Option and is maintaining a Shared Database in the Platform for use by each such Agency in connection with its use of the IDentify Application, and to other Agencies under limited trial licenses for evaluation purposes.
 - (c) **Access to Shared Databases.** Veritone will make available through the IDentify Application, and hereby grants to Licensee the right to access and use, the Shared Databases.
4. **Termination of Participation.** Licensee may terminate its participation in the Data Sharing Option by providing at least 60 days prior written notice to Veritone (or such shorter period as may be required by a court having jurisdiction). In such event, (i) Veritone will restrict access to the Licensee Databases to Licensee only and will terminate access to the Licensee Databases by any other Agency, and (ii) Veritone will terminate Licensee’s access to all Shared Databases, and Licensee’s use of the IDentify Application thereafter will be limited to use with the Licensee Databases only. Licensee acknowledges that Licensee’s right to access and use the Shared Databases is subject at all times to the participation by other Agencies in the Data Sharing Option on a continuous basis. If any Agency terminates its participation in the Data Sharing Option, Licensee will no longer

have access to the Shared Databases of such Agency or to any information generated from the Shared Databases associated with previously run searches and any resulting matches.

5. **Licensee Responsibilities.** Licensee shall be solely responsible for its use of the Shared Databases. Licensee represents and warrants that (a) it will use the Shared Databases solely in conjunction with its use of the IDentify Application in accordance with the terms of this Addendum, and (b) it will use the Shared Databases (including all data, content, materials, information and results contained in and/or generated from any of the foregoing) in compliance with all applicable laws, statutes, ordinances, rules, regulations, consent decrees, and/or requirements of any regulatory authority. Licensee shall defend, indemnify and hold harmless Veritone and its affiliates and licensors, and their respective members, officers, directors, employees, and agents, from and against any liability, losses, damages, judgments, costs and expenses, including litigation costs and reasonable attorneys' fees, arising out of or resulting from Licensee's use of the Shared Databases or Licensee's breach of any of its representations, warranties or obligations set forth in this Addendum.
6. **Authority.** The person executing this Addendum on behalf of each party represents and warrants that he or she has full authority to execute the same on behalf of such party, and that no other actions or approvals are required for such party to enter into this Addendum and perform its obligations hereunder.

IN WITNESS WHEREOF, the parties have caused this Addendum to be executed by their duly authorized representatives as of the date first above written.

VERITONE, INC.

IRVINE POLICE DEPARTMENT

Signature:

Signature:

Name:

Name:

Title:

Title:



LICENSE AGREEMENT

This License Agreement ("Agreement") is entered into as of the date of the last signature below ("Effective Date") by and between Veritone, Inc. (for itself and/or its subsidiaries), having a principal office located at 575 Anton Boulevard, Suite 100, Costa Mesa, CA 92626 ("Veritone") and the entity listed under Licensee Information below ("Licensee"), with respect to license(s) to Veritone's aiWARE Platform and related Services.

Table with sections: LICENSEE INFORMATION, LICENSE AND SERVICES DETAILS, and TERMS AND CONDITIONS. Includes fields for Agency Name, Address, Contact Info, Term, Users, Fees, and Services.

- 1. Master License Terms and Conditions. This Agreement and Licensee's access to and use of the Platform and Services shall be governed by the Veritone Master License Terms and Conditions attached hereto as Attachment A and incorporated herein by reference (the "Terms and Conditions").
2. Identify Application and Cognitive Processing. During the Term, Veritone will provide Licensee with access to the IDentify Application and the cognitive processing specified above for content uploaded to the Platform by Licensee through the IDentify Application.
3. Limitations. Licensee acknowledges that the IDentify Application is intended to be used by Licensee only as a tool to support review of digital evidence in connection with its investigations, and the IDentify Application and the results generated therefrom should not be considered or relied upon as a substitute for Licensee's customary investigative procedures, protocols and/or requirements.
4. Additional Services. Additional Services, such as on-site training, enhanced onboarding and/or support services, will be made available to Licensee for additional fees, which will be quoted by Veritone upon request.
5. Payment Terms. Veritone will submit an invoice to Licensee on a monthly basis for the License Fees due for the following month, and for any amounts incurred for additional Services performed during the previous month, and such invoices will be due and payable net thirty (30) days following the invoice date.

6. **Term and Termination.** Licensee may elect to terminate this Agreement at the expiration of the Trial Term specified above by providing thirty (30) days prior written notice to Veritone. Unless terminated at the expiration of the Trial Term or as otherwise provided herein, this Agreement will automatically continue following the Trial Term for the Initial Term specified above, and will automatically renew thereafter for successive one-year terms (each renewal term together with the Trial Term and Initial Term, collectively the "Term"). Following the Trial Term, either party may terminate this Agreement at any time, for any reason or no reason, by providing at least sixty (60) days prior written notice to the other party.
7. **Authority.** The person executing this Agreement on behalf of each party represents and warrants that he or she has full authority to execute the same on behalf of such party, and that no other actions or approvals are required for such party to enter into this Agreement and perform its obligations hereunder.

ACCEPTED AND AGREED BY:	
VERITONE, INC.	LICENSEE
Signature:	Signature:
Name:	Name:
Title:	Title:
Date:	Date:

ATTACHMENT A

**VERITONE, INC. MASTER LICENSE TERMS AND CONDITIONS
(PS-Rev 20180907)**

(Attached)

VERITONE, INC.

MASTER LICENSE TERMS AND CONDITIONS

These Master License Terms and Conditions (“Terms and Conditions”) apply to any License Agreement (as defined below) between Veritone, Inc. (or one of its subsidiaries) (“Veritone”) and a licensee (“Licensee”).

- 1. License Agreement; Controlling Terms.** For purposes hereof, “License Agreement” shall mean the written license agreement, or the order form, subscription form, statement of work or other document, including any addenda or exhibits thereto, accepted by Veritone in writing, that evidences the purchase of a license from Veritone by the Licensee (either directly or through an authorized reseller of Veritone) to access and use the Veritone aiWARE Platform (the “Platform”) and associated Services (as defined below). The Platform is an artificial intelligence operating system that delivers near real-time media processing and analytics, enabling users to process, index, organize, manage, search, analyze and share audio, video and other data through a suite of applications and other services (collectively, the “Services”). The specific Services, content, fees and payment terms, number of authorized users, and the term of license shall be as set forth in the License Agreement. The License Agreement may also contain other license-specific terms and conditions. The License Agreement and these Terms and Conditions are collectively referred to herein as this “Agreement.” In the event of any conflict or inconsistency among the terms and conditions set forth in the License Agreement and in these Terms and Conditions, the rights and obligations of the parties shall be interpreted based on the following order of priority: (1) the License Agreement and (2) these Terms and Conditions. This Agreement constitutes the complete and exclusive agreement between the parties with respect to the Platform and Services, superseding and replacing any and all prior agreements, communications, and understandings, both written and oral, regarding such subject matter, and no additional or different provision contained in any purchase order form, order acknowledgment form, invoice or similar form of either party will be effective.
- 2. License, Reservation of Rights, Restrictions.**
 - 2.1. License.** Veritone hereby grants to Licensee, during the Term (as defined in Section 7 below), a non-transferable, non-sublicensable, non-exclusive, revocable license to access and use the Platform and Services, subject to the terms and conditions set forth in this Agreement (the “License”). Licensee agrees to use the Platform and Services only for its internal business purposes in accordance with the terms of this Agreement. For the avoidance of doubt, the Platform and Services and its content may not be displayed publicly; provided that, subject to the provisions of Section 2.4 (Restrictions) and Section 11 (Indemnification) of this Agreement, Licensee may post, publish or otherwise share its owned or licensed content via the Platform for which sharing capabilities are enabled during the Term in accordance with the terms of this Agreement.
 - 2.2. Reservation of Rights.** The Platform and Services are licensed by Veritone to Licensee, and not sold. Licensee acquires only the right to use the Platform and Services in accordance with this Agreement and does not acquire any rights of ownership. Nothing herein shall be construed to transfer any rights, title or ownership of any Veritone or Veritone-licensed software, technology, materials, information or Intellectual Property Rights to Licensee. All right, title and interest (including all Intellectual Property Rights) in and to the Platform and Services shall at all times remain the sole and exclusive property of Veritone and/or its respective licensors and all use thereof shall inure to the benefit of Veritone and/or its respective licensors. Except as expressly set forth in this Agreement, no right or license, express or implied, is granted to Licensee or any third party by estoppel, implication, exhaustion or other doctrine of law, equity or otherwise with respect to any product, service, software, technology, materials, information or Intellectual Property Rights of Veritone or its affiliates or licensors. “**Intellectual Property Rights**” means all forms of proprietary rights, titles, interests, and ownership including patents, patent rights, copyrights, trademarks, trade dresses, trade secrets, know-how, mask works, *droit moral* (moral rights), publicity rights and all similar rights of every type that may exist now or in the future in any jurisdiction, including without limitation all applications and registrations therefore and rights to apply for any of the foregoing.
 - 2.3. Third Party Licenses.** Certain software components of the Platform and Services are supplied pursuant to license agreements from third parties, and Licensee agrees that Licensee’s use of the Platform and Services shall be subject to the provisions of such third party license agreements.
 - 2.4. Restrictions.**
 - 2.4.1. License Restrictions.** Licensee agrees to use the Platform and Services only for lawful purposes and only as expressly authorized under this Agreement. Without limiting the generality of the foregoing, except as expressly authorized hereunder, Licensee agrees that it shall not, directly or indirectly: (i) license, sublicense, sell, resell, rent, lease, transfer, assign, distribute, display or otherwise make the Platform or Services, in whole or in part, including any content or data derived therefrom that is not directly owned by Licensee or for which Licensee has

all necessary rights, available to any third party, or use the Platform or Services to provide services to any third party; (ii) reverse engineer, decompile, disassemble, modify, translate, reconstruct, omit, distort, obscure, copy or create derivative works of all or any portion of the Platform, Services, any underlying software, or any other Veritone Property (as defined below), or otherwise attempt to access the source code of the Platform or Services; (iii) incorporate any portion of the Platform or Services into Licensee's own programs or compile any portion of them in combination with Licensee's own programs; (iv) store or otherwise capture to physical media, or enable a third party to store or capture, the Platform or Services or any portion thereof; (v) permit any persons, other than Licensee's authorized users for which Licensee has procured User IDs pursuant to the License Agreement, to access and use the Platform or Services; (vi) upload or transmit through the Platform or Services any material, content, media or data (collectively, "Licensee Content") with respect to which Licensee does not either own all right, title and interest or have the appropriate license(s) for lawful use, or otherwise violate or infringe upon the intellectual property rights of any third party in Licensee's use of the Platform or Services, including the use or distribution of any data derived from the Platform or Services; or (vii) violate any laws, rules or regulations in connection with its use of the Platform or Services, including any data or content contained in, transmitted through or derived therefrom.

2.4.2. Prohibited Acts. Licensee acknowledges and agrees that Licensee is prohibited from doing any act that may have the effect of undermining the integrity of the Platform, Services, any related computer systems, infrastructure or environment, or the methods by which Veritone provides Services to users. Without limiting the generality of the foregoing, Licensee agrees that it shall not, directly or indirectly: (i) defeat, circumvent or modify any authentication technology or other security measures, controls, limitations, or content or functionality filters contained in or associated with the Platform or Services, or otherwise attempt to access any aspect of the Platform or Services that Licensee has not been granted authorization to access under the License Agreement; (ii) deploy or facilitate the use or deployment of any script, routine, robot, spider, scraper or any other automated means, method or device with respect to Licensee's access and use of the Platform and Services for any purpose, including to access, view, select, or copy in whole or in part, any content, program, functionality of the Platform or Services, or any other proprietary information or trade secret of Veritone that is made available through the Platform or Services; (iii) deploy or facilitate the use or deployment of any program, system, means, method or device, for any purpose that places an unreasonable, unnecessary or excessive demand or load on the Platform, Services, or related hardware and connections, or prohibits, denies or delays access to Services by other users or otherwise threatens the continuous services of Veritone's ISPs, suppliers and vendors; (iv) introduce into the Platform or Services any program, executable file or routine (such as a worm, Trojan horse, cancel-bot, time bomb or virus) irrespective of whether any such program or routine results in detrimental harm to the Platform, Services, or any underlying systems or programs; (v) remove any proprietary notices, labels or marks from the Platform or Services; (vi) establish any direct or deep link or other connection to any specific page or location within the Platform or Services, other than the Platform log-in page; (vii) use or attempt to use another user's account without authorization, or interfere with another user's access to the Platform or Services; or (viii) access or use the Platform or Services to design, develop, build, market or support a competitive product or service.

3. Access and Use. Veritone will enable Licensee to access and use the Platform for the duration of the Term, subject to any early termination of this Agreement in accordance with the terms hereof. Access to the Platform will be through unique log-in credentials assigned to Licensee by Veritone (each, a "User ID"). Licensee shall be given that number of User IDs as specified in the License Agreement. Licensee will provide accurate and complete information in registering its authorized users for account access. Licensee acknowledges and agrees that the log-in credentials assigned hereunder are Confidential Information and may only be used by Licensee and its authorized users to access the Platform in accordance with the terms of this Agreement, and that Licensee will not publish, share, or otherwise enable any third party, directly or indirectly, to access the Platform for any purpose. Licensee further agrees that Licensee is responsible for its and its authorized users' use of the Platform, including use via the User IDs, and for any consequences thereof. Licensee agrees to immediately notify Veritone of any unauthorized or improper use of any log-in credentials of Licensee. All of the rights, obligations, restrictions, representations and warranties related to Licensee's access and use of the Platform under this Agreement shall apply to Licensee and all of Licensee's employees, contractors, consultants, representatives and agents (collectively, "Representatives"). Licensee shall be responsible for all acts and omissions of its Representatives in the performance of this Agreement and for any breach of this Agreement by any of its Representatives.

4. Intellectual Property.

4.1. Veritone Property. As between Veritone and Licensee, Veritone and/or its respective licensors retain all right, title and interest (including Intellectual Property Rights) in and to the Platform and Services, including, but not limited to any

elements, components, content, technology, software, code, documentation, derivative works, revisions, enhancements, modifications, condensations and/or compilations of or relating to the Platform and Services, and any trademarks, brand identifiers, materials and information, which are created, authored, developed, conceived and/or reduced to practice by Veritone and/or its respective licensors, including in connection with Veritone's provision of the Platform and Services to Licensee under this Agreement ("**Veritone Property**").

4.2. Licensee Property. As between Licensee and Veritone, Licensee retains all right, title and interest (including Intellectual Property Rights) in and to the Licensee Content, and any software, technology, trademarks, brand identifiers, materials and information which are independently created, authored, developed, conceived or reduced to practice by Licensee.

5. Licensee Content.

5.1. Content Ownership. Licensee represents and warrants that (i) Licensee and/or its licensors own all right, title and interest in and to all Licensee Content uploaded to or transmitted through the Platform or Services, or otherwise have all rights in such Licensee Content as necessary to use the same in connection with Licensee's use of the Platform and Services, (ii) such Licensee Content does not and will not misappropriate or infringe upon any third party's Intellectual Property Rights, or violate any other rights of any third party, and (iii) Licensee has all rights in such Licensee Content necessary to grant the rights contemplated by this Agreement.

5.2. License to Content. Unless otherwise specified in the License Agreement, Licensee hereby grants to Veritone a non-exclusive, royalty-free, worldwide license (i) to use and display all Licensee Content that Licensee provides to Veritone or that are otherwise uploaded to or captured by the Platform through Licensee's use of the Platform and Services to provide the Services and perform its obligations under this Agreement, directly or through its third party service providers, and (ii) to share such Licensee Content with Veritone's third party service providers solely as required for Veritone's provision of the Platform and Services to Licensee.

5.3. Data Security and Destruction. Veritone will maintain and use adequate administrative, physical, and technical safeguards for protection of the security, confidentiality and integrity of all Licensee Content uploaded to or transmitted through the Platform or Services. Licensee Content shall be used and stored by Veritone solely to the extent required to provide the Services and perform its obligations under this Agreement or as otherwise expressly provided in the License Agreement, and Veritone shall not use or store the Licensee Content for any other purpose whatsoever. Upon termination of this Agreement or upon the written request of Licensee at any time, Veritone shall ensure the secure deletion and destruction of all Licensee Content.

6. Feedback. During the Term, Licensee may provide Veritone with such written evaluations, comments and/or suggestions (collectively, "**Feedback**") regarding the Platform or Services. Licensee acknowledges and agrees that any Feedback provided to Veritone by Licensee hereunder shall be deemed to be Veritone Property and Licensee hereby assigns all right, title and interest in and to such Feedback to Veritone and acknowledges that Veritone will be entitled to, without limitation, implement and exploit any such Feedback in any manner without any restriction or obligation. Notwithstanding the foregoing, Licensee acknowledges that Veritone is not obligated to act on any such Feedback.

7. Term and Termination.

7.1. Term. The term of this Agreement and the License shall be as set forth in the License Agreement (the "**Term**").

7.2. Termination. In addition to any termination rights expressly provided in the License Agreement, this Agreement may be terminated by either party if the other party (i) materially breaches any provision of this Agreement which remains uncured for a period of fourteen (14) days from the date of written notice of such breach; or (ii) makes an assignment for the benefit of its creditors, is declared insolvent, or has a receiver or trustee in bankruptcy appointed to take charge of all or part of such party's property.

7.3. Effect of Termination. If at any time this Agreement is terminated, or upon expiration of the Term, the License and all other rights granted to Licensee herein shall automatically terminate and Licensee shall immediately cease using the Platform and Services.

7.4. Survival. The provisions of Sections 2.2 (Reservation of Rights), 4 (Intellectual Property), 6 (Feedback), 7.3 (Effect of Termination), 8.1 (Fees and Payments), 8.2 (Taxes), 10 (Confidentiality), 11 (Indemnification), 12.2 and 12.3 (Warranty and Disclaimers), 13 (Limitation of Liability), 14 (Miscellaneous) hereof and the payment terms of License Agreement, as applicable, shall survive the expiration or any early termination of this Agreement for any reason.

8. Fees, Charges and Payments.

8.1. Fees and Payments. In consideration for the License and Licensee's access and use of the Platform and Services, Licensee shall pay the license fees, and any applicable additional fees, as set forth in the License Agreement (collectively, the "Fees"). All Fees and other amounts due under this Agreement are payable in U.S. dollars.

8.2. Taxes. All Fees and any other amounts due hereunder are exclusive of taxes and similar assessments which may be imposed on the delivery of the Platform and Services and any other transactions contemplated hereby. Licensee shall be solely responsible for the payment of any and all sales, use, value added, excise, import, or other similar taxes or payments in lieu thereof, including interest and penalties thereon, imposed by any authority, government or governmental agency arising out of or in connection with amounts due hereunder (other than those levied on Veritone's income), and Licensee shall make such payments, and timely file any return or information required by treaty, law, rule or regulation. Upon request, Licensee shall provide Veritone with documentation evidencing such payments. If Veritone is required to pay any such taxes, duties or fees, Licensee shall reimburse Veritone immediately upon receipt of Veritone's invoice thereof.

8.3. Suspension of Platform Access. In addition to Veritone's termination rights set forth herein and without prejudice to any other rights of Veritone at law or in equity, Veritone may suspend its performance under this Agreement and any other agreement with Licensee and Licensee's access to the Platform if Licensee fails to comply with any part of its payment obligations set forth herein. Such suspension of service shall not suspend or otherwise affect Licensee's payment obligations set forth herein.

9. Changes to Platform, Service and Fees. Veritone may, from time to time, in its sole discretion, make changes to the Platform and Services, or a portion thereof including, without limitation, formats, content, reports, functionality, and/or techniques ("Service Change"). In the event of a Service Change, Veritone may, adjust the Fees for the Platform and Services ("Fee Change") in writing. Such Fee Change shall become effective on the date stated in Veritone's notice to Licensee unless, within fifteen (15) days after a Fee Change notice that would result in an increase in the Fees, Licensee notifies Veritone in writing of its refusal to accept the Fee Change, in which event the applicable License to Licensee shall terminate as of the effective date of the change; provided, however, that if the Fee Change is an increase in the Fees, Veritone may, in its sole discretion, elect to rescind the Fee Change, in which case the Platform and Services, as changed, shall continue as provided herein.

10. Confidentiality.

10.1. Confidential Information. Each party (a receiving party) acknowledges and agrees that during the Term and in the course of using the Platform and Services and performing its duties under this Agreement, it may obtain information relating to the other party (a disclosing party), its and/or its customers', vendors', or third party service providers' business or technologies, which is of a confidential and proprietary nature ("**Confidential Information**"). Such Confidential Information may include, but is not limited to, trade secrets, know-how, inventions, techniques, processes, software, algorithms, programs, schematics, data, technology roadmap, sales and marketing plans, and any other information which the receiving party knows or has reason to know is, or which by its nature would reasonably be considered to be, confidential, proprietary or trade secret information of the other party. Without limiting the foregoing, Confidential Information of Veritone shall include the Platform, Services and all associated software and documentation, as well as Feedback or any results of the evaluation or testing of the Platform or Services. The receiving party shall at all times, both during the Term and for a period of three (3) years after its termination (or, in the case of the Platform, Services and any associated software or trade secrets, in perpetuity), keep in trust and confidence all Confidential Information of the disclosing party, and shall not (i) use such Confidential Information other than as expressly authorized under this Agreement or as required for the receiving party to perform its obligations under this Agreement, or (ii) disclose any Confidential Information of the disclosing party to third parties (other than to Veritone's third party service providers in connection with the performance of its obligations under this Agreement), without the disclosing party's prior written consent. The receiving party further agrees to immediately return to the disclosing party or destroy all Confidential Information (including all copies, extracts and summaries thereof) in the receiving party's possession, custody, or control upon the expiration or any termination of this Agreement. The obligations of confidentiality shall not apply to information which (a) has entered the public domain except where such entry is the result of the receiving party's breach of this Agreement; (b) prior to disclosure hereunder, was already in the receiving party's possession and not subject to any confidentiality obligations, as demonstrated by written evidence; (c) subsequent to disclosure hereunder is obtained by the receiving party on a non-confidential basis from a third party who has the right to disclose such information to the receiving party; or (d) has been independently developed by the receiving party without use of or reference to the disclosing party's Confidential Information, as demonstrated by written evidence.

10.2. Permitted Disclosures. The receiving party may make disclosures (i) as required by applicable law or the rules of an stock exchange on which such party's shares are then traded; or (ii) as compelled by court order issued by a court of competent

jurisdiction provided that the receiving party subject to such court order (a) provides the disclosing party with prompt written notice of any such compelled disclosure, (b) uses diligent reasonable efforts to limit disclosure, (c) uses commercially reasonable efforts to obtain confidential treatment or a protective order in connection with the information subject to such compelled disclosure, and (d) allows the disclosing party to participate in any such proceeding.

11. Indemnification.

11.1. Licensee Indemnification of Veritone. Licensee will defend, indemnify and hold harmless Veritone and its subsidiaries, affiliates, successors, assigns, licensors, and their respective members, officers, directors, employees, licensors, agents, from and against any liability or expense, including, without limitation, any expenses, losses, damages, judgments, litigation costs and reasonable attorneys' fees, that Veritone may incur as a result of any claim, suit or proceeding brought against Veritone by any third party arising or resulting from (a) Licensee's breach of any representation, warranty, covenant or obligation contained in this Agreement; or (b) Licensee's use of the Platform or Services (including uploading, using, publishing, posting or otherwise sharing of Licensee's Content or any other data or content derived from the Platform or Services) in any manner that violates this Agreement or any laws, rules, regulations or third party terms and conditions, or that misappropriates or infringes the rights (including Intellectual Property Rights) of any third party; *provided that* Veritone gives Licensee prompt notice of any such claims, cooperates with Licensee in responding to such claims, and permits Licensee to control the defense or settlement of such claims, subject to Veritone's right to (i) conduct the defense of such claims at Veritone's expense, or participate in the defense of such claims with its own counsel at its own expense, and (ii) approve any settlement that binds or purports to bind Veritone.

11.2. Veritone Indemnification of Licensee. Veritone will defend, indemnify and hold harmless Licensee and its subsidiaries, affiliates, successors, assigns, licensors, and their respective members, officers, directors, employees, licensors, agents, from and against any liability or expense, including without limitation, any expenses, losses, damages, judgments, litigation costs and reasonable attorneys' fees that Licensee may incur as a result of any claim, suit or proceeding brought against Licensee by any third party arising or resulting from (a) Veritone's breach of any representation, warranty, covenant or obligation contained in this Agreement; or (b) any allegation that the Platform or Services, or any part thereof, misappropriates or infringes upon any third party's Intellectual Property Rights, except to the extent such claims arise from Licensee's negligence, misconduct or violation of any terms of this Agreement; *provided that* Licensee gives Veritone prompt notice of any such claims, cooperates with Veritone in responding to such claims, and permits Veritone to control the defense or settlement of such claims, subject to Licensee's right to (i) conduct the defense of such claims at Licensee's expense, or participate in the defense of such claims with its own counsel at its own expense, and (ii) approve any settlement that binds or purports to bind Licensee. If the Platform, in whole in part, becomes or, in Veritone's opinion is likely to become, the subject of an infringement claim or action, Veritone may, at its option: (x) procure, at no cost to Licensee, the right for Licensee to continue using the Platform; (y) replace or modify the Platform to render the Platform non-infringing, provided there is no material loss of functionality; or (z) if, in Veritone's reasonable opinion, neither (x) nor (y) above is commercially feasible, terminate this Agreement and refund any prepaid amounts for unused Services during the terminated portion of the Term. The foregoing states Veritone's sole obligation and Licensee's exclusive remedy in the event any such infringement claim or action is commenced or is likely to be commenced.

12. Warranties and Disclaimers.

12.1. Mutual Warranties. Each party represents and warrants to the other that: (i) it is duly organized and validly existing under the laws of the jurisdiction of its incorporation or formation, and has full power, rights and authority to enter into this Agreement and carry out its obligations hereunder; (ii) the person executing this Agreement is authorized to do so on its behalf; (iii) this Agreement is valid and legally binding upon it and (iv) the execution, delivery and performance thereof by such party does not conflict with any other agreement, instrument or understanding to which it is a party or by which it may be bound, nor would violate any applicable law or regulation.

12.2. Disclaimer. THE PLATFORM, SERVICES AND ANY OTHER VERITONE PRODUCTS AND SERVICES ARE PROVIDED ON AN "AS IS" AND "AS AVAILABLE" BASIS. EXCEPT AS EXPRESSLY PROVIDED IN THIS AGREEMENT, VERITONE MAKES NO WARRANTY, EXPRESS OR IMPLIED, WITH RESPECT TO THE PLATFORM AND SERVICES, INCLUDING, WITHOUT LIMITATION, ANY WARRANTY AS TO THE ACCURACY OF PROCESSING RESULTS, ANY WARRANTY OF MERCHANTABILITY, QUALITY OR FITNESS FOR A PARTICULAR PURPOSE, WARRANTIES ARISING FROM COURSE OF DEALING OR USAGE OF TRADE, AND WARRANTIES OF NON-INFRINGEMENT. VERITONE DOES NOT WARRANT THAT THE PLATFORM AND SERVICES ARE ERROR-FREE, WILL RUN UNINTERRUPTED, OR THAT ALL ERRORS CAN OR WILL BE CORRECTED. NO ADVICE OR INFORMATION, WHETHER ORAL OR WRITTEN, OBTAINED BY LICENSEE FROM VERITONE SHALL CREATE ANY SUCH WARRANTY.

12.3. LICENSEE ACKNOWLEDGES AND AGREES THAT THE INTERNET IS A PUBLIC NETWORK OVER WHICH VERITONE EXERTS NO CONTROL. VERITONE MAKES NO REPRESENTATIONS OR WARRANTIES WHATSOEVER, AND SHALL HAVE NO LIABILITY WHATSOEVER, WITH RESPECT TO THE ACCURACY, DEPENDABILITY, PRIVACY, SECURITY, AUTHENTICITY OR COMPLETENESS OF DATA TRANSMITTED OVER OR OBTAINED USING THE INTERNET OUTSIDE OF THOSE SYSTEMS AND NETWORKS CONTROLLED BY VERITONE, OR ANY INTRUSION, VIRUS, DISRUPTION, LOSS OF COMMUNICATION, LOSS OR CORRUPTION OF DATA, OR OTHER ERROR OR EVENT CAUSED OR PERMITTED BY OR INTRODUCED THROUGH LICENSEE'S OWN USE OF THE INTERNET. LICENSEE IS SOLELY RESPONSIBLE FOR IMPLEMENTING ADEQUATE FIREWALL, PASSWORD AND OTHER SECURITY MEASURES TO PROTECT ITS SYSTEMS, DATA AND APPLICATIONS FROM UNWANTED INTRUSION, WHETHER OVER THE INTERNET OR BY OTHER MEANS.

13. Limitation of Liability.

13.1. EXCEPT FOR (A) BREACHES OF EACH PARTY'S OBLIGATIONS UNDER SECTION 10 (CONFIDENTIALITY), AND (B) AMOUNTS FINALLY AWARDED OR SETTLED IN A THIRD PARTY CLAIM FOR WHICH A PARTY IS RESPONSIBLE UNDER SECTION 11 (INDEMNIFICATION), NEITHER PARTY, INCLUDING ITS OFFICERS, DIRECTORS, EMPLOYEES, REPRESENTATIVES AND AFFILIATES, SHALL BE LIABLE FOR ANY INDIRECT, INCIDENTAL, SPECIAL, CONSEQUENTIAL, OR PUNITIVE DAMAGES, INCLUDING WITHOUT LIMITATION, LOST DATA OR LOST PROFITS, OR COSTS OF PROCURING SUBSTITUTE GOODS OR SERVICES, HOWEVER ARISING, EVEN IF IT HAS BEEN ADVISED OF THE POSSIBILITY OF SUCH DAMAGES.

13.2. EXCEPT WITH RESPECT TO EACH PARTY'S CONFIDENTIALITY AND INDEMNIFICATION OBLIGATIONS HEREUNDER, NEITHER PARTY'S LIABILITY FOR DAMAGES ARISING OUT OF, RELATING TO OR IN ANY WAY CONNECTED WITH THIS AGREEMENT SHALL EXCEED THE TOTAL FEES PAID BY LICENSEE TO VERITONE UNDER THIS AGREEMENT.

14. MISCELLANEOUS

14.1. No Assignment. Neither party may assign any of its rights or obligations under this Agreement without the prior written consent of the other party, except that either party may assign its rights and obligations under this Agreement without the consent of the other party to an affiliate directly or indirectly controlling, controlled by, or under direct or indirect common control with such party or in connection with any merger (by operation of law or otherwise), consolidation, reorganization, change in control or sale of all or substantially all of its assets related to this Agreement or similar transaction. This Agreement inures to the benefit of and shall be binding on the parties' permitted assignees, transferees and successors.

14.2. Severability. If any provision of this Agreement is found by a court of competent jurisdiction to be invalid, the parties nevertheless agree that the court should endeavor to give effect to the parties' intentions as reflected in such provision, and the other provisions of this Agreement remain in full force and effect.

14.3. No Waiver. The failure of either party to exercise or enforce any right or provision of this Agreement shall not constitute a waiver of such right or provision.

14.4. Controlling Law. This Agreement shall be governed by and construed in accordance with the laws of the State of California (other than the conflict of law rules) and subject to the sole jurisdiction of the courts sitting in Orange County, California. Notwithstanding the foregoing, nothing in this Section 14.4 shall be deemed to limit the parties' rights to seek injunctive relief in any other court of law of competent jurisdiction.

14.5. Independent Contractors. This Agreement does not create any relationship other than Veritone as an independent contractor performing services covered by this Agreement and Licensee as the party contracting with Veritone for those services. No party is a partner or a legal representative of the other for any purpose whatsoever, nor is any party authorized to make any contract, agreement or warranty on behalf of any other party. Under no circumstance shall one party's employees be construed to be employees of the other party.

14.6. Publicity. Except as required or compelled by applicable law, the rules of any stock exchange, or a court order issued by a court of competent jurisdiction, neither party will make any public statement regarding, or disclose, advertise or publish the terms and conditions of this Agreement without the prior written consent of the other party; provided, however, that Veritone may reference Licensee on Veritone's website, other marketing materials, investor relations materials, and as a customer in Veritone's SEC filings.

14.7. Notices. All notices to either party shall be in writing and delivered by hand or by certified mail or overnight delivery service to the address set forth by Licensee and/or Veritone in the License Agreement, or to such other address as either party shall provide by notice to the other party. Alternatively, the parties may, at their election, utilize email as the method of delivery of any such notice to be provided hereunder. Any such notices sent by email shall be delivered to the email addresses set forth in the License Agreement, or such other email address as designed by a party during the Term. Notices shall be deemed effective when delivered to the applicable address, unless any such notice is sent by

email, in which event, notice shall be deemed effective upon confirmation of delivery by a “read receipt” or other such notice generated by the applicable email system, but in any event, by reply of the recipient of such notice.

- 14.8. Electronic Communication.** In connection with its use of the Platform and Services, Licensee consents to receiving communications from Veritone electronically. Veritone will communicate with Licensee by e-mail or by posting notices on the Platform or through any Services. Licensee agrees that all notices, disclosures and other communications that Veritone provides to Licensee electronically satisfy any legal requirement that such communications be in writing.
- 14.9. Force Majeure.** Except for the obligation to make payments of any Fees or any other amounts due hereunder, neither party will be liable for any failure or delay in its performance under the Agreement due to any cause beyond such party’s control including acts of war, terrorism, acts of God, embargo, riot, sabotage, labor shortage or dispute, governmental act, or failure of the Internet, or any component comprising or operating the network infrastructure thereof (each, a “**Force Majeure Event**”), provided that the delayed party: (i) gives the other party prompt notice of such cause, and (ii) uses its reasonable commercial efforts to promptly correct such failure or delay in performance. If Veritone is unable to provide Service(s) for a period of sixty (60) consecutive days as a result of a continuing Force Majeure Event, either party may elect to terminate this Agreement.
- 14.10. Construction.** This Agreement shall be fairly interpreted and construed in accordance with its terms and without strict interpretation or construction in favor of or against either party. Each party has had the opportunity to consult with counsel in the negotiation of this Agreement.
- 14.11. Counterparts.** This Agreement may be executed in one or more counterparts (including fax or email) each of which shall be deemed an original but all of which taken together shall be deemed one and the same instrument.
- 14.12. Headings.** Unless otherwise expressly stated in this Agreement, the words “herein,” “hereof,” “hereto,” and “hereunder” and other words of similar import refer to this Agreement as a whole and not to any particular section, subsection, or other subdivision. The words “include” and “including” shall not be construed or interpreted as terms of limitation. The words “day,” “month,” and “year” mean, respectively, calendar day, calendar month, and calendar year. Section headings are for reference purposes only, and should not be used in the interpretation hereof.
- 14.13. Amendment.** No addendum, waiver, consent, modification, amendment or change of the terms of this Agreement shall bind either party unless in a writing that references this Agreement and is signed by duly authorized representatives of Licensee and Veritone.
- 14.14. Attorney’s Fees.** If any action arises under this Agreement, including, without limitation the interpretation or enforcement of any term of this Agreement, the prevailing party in any such action shall be entitled to recover its reasonable attorney’s fees and related costs.

From: William Hillyard
Sent: Tuesday, February 5, 2019 12:52 PM PST
To: Tom Avery
Subject: FW: Veritone pilot agreement
Attachments: image001.png, ATT00001.htm, Irvine PD Data Sharing Addendum (20190128).docx, ATT00002.htm, Irvine Police Department License Agreement (IDentify) (20190128).docx, ATT00003.htm, Master License Terms and Conditions (PS Rev 20180907).pdf, ATT00004.htm, image001.png, ATT00005.htm, image001.png

Tom,

Can you please see the question below from Lt. Anderson. In the agreement it states the waived fee is \$15,000 per month, is that meant to be per year for the license fee we discussed in the meeting?

Thank you,



William Hillyard | Detective | Irvine Police Department
949-724-7085 | 1 Civic Center Plaza, Irvine, CA 92606
whillyard@cityofirvine.org | cityofirvine.org

From: Mark Anderson <manderson@cityofirvine.org>
Sent: Monday, February 04, 2019 2:18 PM
To: William Hillyard <whillyard@cityofirvine.org>
Subject: FW: Veritone pilot agreement

Hi Sir. In the License Agreement attached it talked about 15,000 per month, but it's waived? Just not clear what that means. Can you take and look at it and explain or reach out to Veritone and ask for an explanation. Thank you

From: William Hillyard
Sent: Thursday, January 31, 2019 8:13 AM
To: Mark Anderson <manderson@cityofirvine.org>
Subject: FW: Veritone pilot agreement

LT,

Attached are the documents for the Pilot Program agreement with Veritone that need Chief Hamel's signature. Here are some brief points regarding the agreements:

- Irvine PD can opt out of the data sharing portion of the software at any time. If we did opt out but continued to use the software the suspect photos would only be compared to our database of known offenders, and no other agencies would have access to our database of booking photos and known offenders.

- The free trial period for the Pilot Program is 90 days, not 60 as was discussed during our meeting with Veritone.
- The initial License Agreement states that we will have (5) user profiles. This is only for the term of the Pilot Program. If we go forward with purchasing the software we will have an unlimited number of user licenses.
- Section 5.3 of the Master License Terms and Conditions states that if we cancel our relationship with Veritone any data we have provided them is removed from their servers and deleted. There are several portions throughout the agreements which clearly spell out that the data provided by Irvine PD remains the property of Irvine PD and should we terminated our contract with them they have no rights to retain or continue to use any data we provided them.
- The data we are providing other agencies access to through Veritone is no different than the data we upload to Coplink on a daily basis.
- For the Pilot Program we will provide Veritone with an initial data dump of our current database of booking photos, if we go forward with purchasing the software Veritone can set up and automated upload of new booking photos so there is no additional workload for our personnel.

I spoke with Nick Rycroft Monday reference the IT portion of it and he stated when the agreement is signed by the Chief he would begin working on the data export as requested by Veritone.

Please let me know if can provide any additional information.

Thank you,

Bill Hillyard

Begin forwarded message:

From: Tom Avery <tavery@veritone.com>
Date: January 30, 2019 at 7:15:09 AM PST
To: William Hillyard <whillyard@cityofirvine.org>
Subject: Veritone pilot agreement

Bill,

Attached is the Veritone pilot agreement documents which also include the terms and conditions as well as the data sharing agreement. Let me know if you have any questions.

Thanks,
Tom

Tom Avery
Vice President Public Safety
Veritone Government
tavery@veritone.com
Privacy [REDACTED] cell

**Veritone IDentify Application
Data Sharing Addendum**

This Data Sharing Addendum (“Addendum”) is entered into as of February __, 2019, by and between Veritone, Inc. (“Veritone”) and Irvine Police Department (“Licensee”). This Addendum is incorporated by reference into, made a part of and governed by the terms of the License Agreement dated February __, 2019 between Veritone and Licensee (the “Agreement”). In the event of any conflict or inconsistency between the provisions contained in the Agreement and the provisions contained in this Addendum with respect to the subject matter hereof, the provisions of this Addendum shall govern and control. Capitalized terms used but not defined herein shall have the meanings ascribed to them in the Agreement.

1. **IDentify Application.** Veritone has granted to Licensee a right and license to access and use the IDentify Application within the Platform. The IDentify Application allows users to upload booking, arrest and known offender databases (collectively, “Booking Databases”) and use facial recognition technology to compare digital evidence from crime scenes with the Booking Databases to identify potential suspects. The IDentify Application also allows Licensee and other judicial and law enforcement agencies (each, an “Agency”) to elect to share access to their Booking Databases as further described in this Addendum (the “Data Sharing Option”).
2. **Participation in Data Sharing Option.** By executing this Addendum, Licensee hereby elects to participate in the Data Sharing Option, and each of Licensee and Veritone acknowledges and agrees to the supplemental terms and conditions applicable to the Data Sharing Option as set forth in this Addendum, in addition to the terms of the Agreement. All rights granted by each party under this Addendum shall continue during the Term of the Agreement, unless earlier terminated as set forth herein.
3. **Databases.**
 - (a) **Shared Databases.** Licensee will participate in the Data Sharing Option with respect to the Booking Databases indicated below (the option indicated below referred to hereinafter as the “Shared Databases”) (*check/complete one option*):
 - The Booking Databases maintained in the Platform by all other Agencies participating in the Data Sharing Option; or
 - The Booking Databases maintained in the Platform by the following Agencies:
 1. N/A
 - 2.
 - 3.
 - 4.
 - (b) **Access to Licensee Databases.** Licensee hereby grants to Veritone the right to grant access to all Booking Databases that Licensee maintains in the Platform (the “Licensee Databases”) to each other Agency that is participating in the Data Sharing Option and is maintaining a Shared Database in the Platform for use by each such Agency in connection with its use of the IDentify Application, and to other Agencies under limited trial licenses for evaluation purposes.
 - (c) **Access to Shared Databases.** Veritone will make available through the IDentify Application, and hereby grants to Licensee the right to access and use, the Shared Databases.
4. **Termination of Participation.** Licensee may terminate its participation in the Data Sharing Option by providing at least 60 days prior written notice to Veritone (or such shorter period as may be required by a court having jurisdiction). In such event, (i) Veritone will restrict access to the Licensee Databases to Licensee only and will terminate access to the Licensee Databases by any other Agency, and (ii) Veritone will terminate Licensee’s access to all Shared Databases, and Licensee’s use of the IDentify Application thereafter will be limited to use with the Licensee Databases only. Licensee acknowledges that Licensee’s right to access and use the Shared Databases is subject at all times to the participation by other Agencies in the Data Sharing Option on a continuous basis. If any Agency terminates its participation in the Data Sharing Option, Licensee will no longer

have access to the Shared Databases of such Agency or to any information generated from the Shared Databases associated with previously run searches and any resulting matches.

5. **Licensee Responsibilities.** Licensee shall be solely responsible for its use of the Shared Databases. Licensee represents and warrants that (a) it will use the Shared Databases solely in conjunction with its use of the IDentify Application in accordance with the terms of this Addendum, and (b) it will use the Shared Databases (including all data, content, materials, information and results contained in and/or generated from any of the foregoing) in compliance with all applicable laws, statutes, ordinances, rules, regulations, consent decrees, and/or requirements of any regulatory authority. Licensee shall defend, indemnify and hold harmless Veritone and its affiliates and licensors, and their respective members, officers, directors, employees, and agents, from and against any liability, losses, damages, judgments, costs and expenses, including litigation costs and reasonable attorneys' fees, arising out of or resulting from Licensee's use of the Shared Databases or Licensee's breach of any of its representations, warranties or obligations set forth in this Addendum.
6. **Authority.** The person executing this Addendum on behalf of each party represents and warrants that he or she has full authority to execute the same on behalf of such party, and that no other actions or approvals are required for such party to enter into this Addendum and perform its obligations hereunder.

IN WITNESS WHEREOF, the parties have caused this Addendum to be executed by their duly authorized representatives as of the date first above written.

VERITONE, INC.

Signature:

Name:

Title:

IRVINE POLICE DEPARTMENT

Signature:

Name:

Title:



LICENSE AGREEMENT

This License Agreement ("Agreement") is entered into as of the date of the last signature below ("Effective Date") by and between Veritone, Inc. (for itself and/or its subsidiaries), having a principal office located at 575 Anton Boulevard, Suite 100, Costa Mesa, CA 92626 ("Veritone") and the entity listed under Licensee Information below ("Licensee"), with respect to license(s) to Veritone's aiWARE Platform and related Services.

Table with sections: LICENSEE INFORMATION, LICENSE AND SERVICES DETAILS, and TERMS AND CONDITIONS. Includes fields for Agency Name, Address, Contact Info, Term, Users, Fees, and Services.

- 1. Master License Terms and Conditions. This Agreement and Licensee's access to and use of the Platform and Services shall be governed by the Veritone Master License Terms and Conditions attached hereto as Attachment A and incorporated herein by reference (the "Terms and Conditions").
2. Identify Application and Cognitive Processing. During the Term, Veritone will provide Licensee with access to the IDentify Application and the cognitive processing specified above for content uploaded to the Platform by Licensee through the IDentify Application.
3. Limitations. Licensee acknowledges that the IDentify Application is intended to be used by Licensee only as a tool to support review of digital evidence in connection with its investigations, and the IDentify Application and the results generated therefrom should not be considered or relied upon as a substitute for Licensee's customary investigative procedures, protocols and/or requirements.
4. Additional Services. Additional Services, such as on-site training, enhanced onboarding and/or support services, will be made available to Licensee for additional fees, which will be quoted by Veritone upon request.
5. Payment Terms. Veritone will submit an invoice to Licensee on a monthly basis for the License Fees due for the following month, and for any amounts incurred for additional Services performed during the previous month, and such invoices will be due and payable net thirty (30) days following the invoice date.

6. **Term and Termination.** Licensee may elect to terminate this Agreement at the expiration of the Trial Term specified above by providing thirty (30) days prior written notice to Veritone. Unless terminated at the expiration of the Trial Term or as otherwise provided herein, this Agreement will automatically continue following the Trial Term for the Initial Term specified above, and will automatically renew thereafter for successive one-year terms (each renewal term together with the Trial Term and Initial Term, collectively the "Term"). Following the Trial Term, either party may terminate this Agreement at any time, for any reason or no reason, by providing at least sixty (60) days prior written notice to the other party.
7. **Authority.** The person executing this Agreement on behalf of each party represents and warrants that he or she has full authority to execute the same on behalf of such party, and that no other actions or approvals are required for such party to enter into this Agreement and perform its obligations hereunder.

ACCEPTED AND AGREED BY:	
VERITONE, INC.	LICENSEE
Signature:	Signature:
Name:	Name:
Title:	Title:
Date:	Date:

ATTACHMENT A

**VERITONE, INC. MASTER LICENSE TERMS AND CONDITIONS
(PS-Rev 20180907)**

(Attached)

VERITONE, INC.

MASTER LICENSE TERMS AND CONDITIONS

These Master License Terms and Conditions (“Terms and Conditions”) apply to any License Agreement (as defined below) between Veritone, Inc. (or one of its subsidiaries) (“Veritone”) and a licensee (“Licensee”).

- 1. License Agreement; Controlling Terms.** For purposes hereof, “License Agreement” shall mean the written license agreement, or the order form, subscription form, statement of work or other document, including any addenda or exhibits thereto, accepted by Veritone in writing, that evidences the purchase of a license from Veritone by the Licensee (either directly or through an authorized reseller of Veritone) to access and use the Veritone aiWARE Platform (the “Platform”) and associated Services (as defined below). The Platform is an artificial intelligence operating system that delivers near real-time media processing and analytics, enabling users to process, index, organize, manage, search, analyze and share audio, video and other data through a suite of applications and other services (collectively, the “Services”). The specific Services, content, fees and payment terms, number of authorized users, and the term of license shall be as set forth in the License Agreement. The License Agreement may also contain other license-specific terms and conditions. The License Agreement and these Terms and Conditions are collectively referred to herein as this “Agreement.” In the event of any conflict or inconsistency among the terms and conditions set forth in the License Agreement and in these Terms and Conditions, the rights and obligations of the parties shall be interpreted based on the following order of priority: (1) the License Agreement and (2) these Terms and Conditions. This Agreement constitutes the complete and exclusive agreement between the parties with respect to the Platform and Services, superseding and replacing any and all prior agreements, communications, and understandings, both written and oral, regarding such subject matter, and no additional or different provision contained in any purchase order form, order acknowledgment form, invoice or similar form of either party will be effective.
- 2. License, Reservation of Rights, Restrictions.**
 - 2.1. License.** Veritone hereby grants to Licensee, during the Term (as defined in Section 7 below), a non-transferable, non-sublicensable, non-exclusive, revocable license to access and use the Platform and Services, subject to the terms and conditions set forth in this Agreement (the “License”). Licensee agrees to use the Platform and Services only for its internal business purposes in accordance with the terms of this Agreement. For the avoidance of doubt, the Platform and Services and its content may not be displayed publicly; provided that, subject to the provisions of Section 2.4 (Restrictions) and Section 11 (Indemnification) of this Agreement, Licensee may post, publish or otherwise share its owned or licensed content via the Platform for which sharing capabilities are enabled during the Term in accordance with the terms of this Agreement.
 - 2.2. Reservation of Rights.** The Platform and Services are licensed by Veritone to Licensee, and not sold. Licensee acquires only the right to use the Platform and Services in accordance with this Agreement and does not acquire any rights of ownership. Nothing herein shall be construed to transfer any rights, title or ownership of any Veritone or Veritone-licensed software, technology, materials, information or Intellectual Property Rights to Licensee. All right, title and interest (including all Intellectual Property Rights) in and to the Platform and Services shall at all times remain the sole and exclusive property of Veritone and/or its respective licensors and all use thereof shall inure to the benefit of Veritone and/or its respective licensors. Except as expressly set forth in this Agreement, no right or license, express or implied, is granted to Licensee or any third party by estoppel, implication, exhaustion or other doctrine of law, equity or otherwise with respect to any product, service, software, technology, materials, information or Intellectual Property Rights of Veritone or its affiliates or licensors. “**Intellectual Property Rights**” means all forms of proprietary rights, titles, interests, and ownership including patents, patent rights, copyrights, trademarks, trade dresses, trade secrets, know-how, mask works, *droit moral* (moral rights), publicity rights and all similar rights of every type that may exist now or in the future in any jurisdiction, including without limitation all applications and registrations therefore and rights to apply for any of the foregoing.
 - 2.3. Third Party Licenses.** Certain software components of the Platform and Services are supplied pursuant to license agreements from third parties, and Licensee agrees that Licensee’s use of the Platform and Services shall be subject to the provisions of such third party license agreements.
 - 2.4. Restrictions.**
 - 2.4.1. License Restrictions.** Licensee agrees to use the Platform and Services only for lawful purposes and only as expressly authorized under this Agreement. Without limiting the generality of the foregoing, except as expressly authorized hereunder, Licensee agrees that it shall not, directly or indirectly: (i) license, sublicense, sell, resell, rent, lease, transfer, assign, distribute, display or otherwise make the Platform or Services, in whole or in part, including any content or data derived therefrom that is not directly owned by Licensee or for which Licensee has

all necessary rights, available to any third party, or use the Platform or Services to provide services to any third party; (ii) reverse engineer, decompile, disassemble, modify, translate, reconstruct, omit, distort, obscure, copy or create derivative works of all or any portion of the Platform, Services, any underlying software, or any other Veritone Property (as defined below), or otherwise attempt to access the source code of the Platform or Services; (iii) incorporate any portion of the Platform or Services into Licensee's own programs or compile any portion of them in combination with Licensee's own programs; (iv) store or otherwise capture to physical media, or enable a third party to store or capture, the Platform or Services or any portion thereof; (v) permit any persons, other than Licensee's authorized users for which Licensee has procured User IDs pursuant to the License Agreement, to access and use the Platform or Services; (vi) upload or transmit through the Platform or Services any material, content, media or data (collectively, "Licensee Content") with respect to which Licensee does not either own all right, title and interest or have the appropriate license(s) for lawful use, or otherwise violate or infringe upon the intellectual property rights of any third party in Licensee's use of the Platform or Services, including the use or distribution of any data derived from the Platform or Services; or (vii) violate any laws, rules or regulations in connection with its use of the Platform or Services, including any data or content contained in, transmitted through or derived therefrom.

2.4.2. Prohibited Acts. Licensee acknowledges and agrees that Licensee is prohibited from doing any act that may have the effect of undermining the integrity of the Platform, Services, any related computer systems, infrastructure or environment, or the methods by which Veritone provides Services to users. Without limiting the generality of the foregoing, Licensee agrees that it shall not, directly or indirectly: (i) defeat, circumvent or modify any authentication technology or other security measures, controls, limitations, or content or functionality filters contained in or associated with the Platform or Services, or otherwise attempt to access any aspect of the Platform or Services that Licensee has not been granted authorization to access under the License Agreement; (ii) deploy or facilitate the use or deployment of any script, routine, robot, spider, scraper or any other automated means, method or device with respect to Licensee's access and use of the Platform and Services for any purpose, including to access, view, select, or copy in whole or in part, any content, program, functionality of the Platform or Services, or any other proprietary information or trade secret of Veritone that is made available through the Platform or Services; (iii) deploy or facilitate the use or deployment of any program, system, means, method or device, for any purpose that places an unreasonable, unnecessary or excessive demand or load on the Platform, Services, or related hardware and connections, or prohibits, denies or delays access to Services by other users or otherwise threatens the continuous services of Veritone's ISPs, suppliers and vendors; (iv) introduce into the Platform or Services any program, executable file or routine (such as a worm, Trojan horse, cancel-bot, time bomb or virus) irrespective of whether any such program or routine results in detrimental harm to the Platform, Services, or any underlying systems or programs; (v) remove any proprietary notices, labels or marks from the Platform or Services; (vi) establish any direct or deep link or other connection to any specific page or location within the Platform or Services, other than the Platform log-in page; (vii) use or attempt to use another user's account without authorization, or interfere with another user's access to the Platform or Services; or (viii) access or use the Platform or Services to design, develop, build, market or support a competitive product or service.

3. Access and Use. Veritone will enable Licensee to access and use the Platform for the duration of the Term, subject to any early termination of this Agreement in accordance with the terms hereof. Access to the Platform will be through unique log-in credentials assigned to Licensee by Veritone (each, a "User ID"). Licensee shall be given that number of User IDs as specified in the License Agreement. Licensee will provide accurate and complete information in registering its authorized users for account access. Licensee acknowledges and agrees that the log-in credentials assigned hereunder are Confidential Information and may only be used by Licensee and its authorized users to access the Platform in accordance with the terms of this Agreement, and that Licensee will not publish, share, or otherwise enable any third party, directly or indirectly, to access the Platform for any purpose. Licensee further agrees that Licensee is responsible for its and its authorized users' use of the Platform, including use via the User IDs, and for any consequences thereof. Licensee agrees to immediately notify Veritone of any unauthorized or improper use of any log-in credentials of Licensee. All of the rights, obligations, restrictions, representations and warranties related to Licensee's access and use of the Platform under this Agreement shall apply to Licensee and all of Licensee's employees, contractors, consultants, representatives and agents (collectively, "Representatives"). Licensee shall be responsible for all acts and omissions of its Representatives in the performance of this Agreement and for any breach of this Agreement by any of its Representatives.

4. Intellectual Property.

4.1. Veritone Property. As between Veritone and Licensee, Veritone and/or its respective licensors retain all right, title and interest (including Intellectual Property Rights) in and to the Platform and Services, including, but not limited to any

elements, components, content, technology, software, code, documentation, derivative works, revisions, enhancements, modifications, condensations and/or compilations of or relating to the Platform and Services, and any trademarks, brand identifiers, materials and information, which are created, authored, developed, conceived and/or reduced to practice by Veritone and/or its respective licensors, including in connection with Veritone's provision of the Platform and Services to Licensee under this Agreement ("**Veritone Property**").

4.2. Licensee Property. As between Licensee and Veritone, Licensee retains all right, title and interest (including Intellectual Property Rights) in and to the Licensee Content, and any software, technology, trademarks, brand identifiers, materials and information which are independently created, authored, developed, conceived or reduced to practice by Licensee.

5. Licensee Content.

5.1. Content Ownership. Licensee represents and warrants that (i) Licensee and/or its licensors own all right, title and interest in and to all Licensee Content uploaded to or transmitted through the Platform or Services, or otherwise have all rights in such Licensee Content as necessary to use the same in connection with Licensee's use of the Platform and Services, (ii) such Licensee Content does not and will not misappropriate or infringe upon any third party's Intellectual Property Rights, or violate any other rights of any third party, and (iii) Licensee has all rights in such Licensee Content necessary to grant the rights contemplated by this Agreement.

5.2. License to Content. Unless otherwise specified in the License Agreement, Licensee hereby grants to Veritone a non-exclusive, royalty-free, worldwide license (i) to use and display all Licensee Content that Licensee provides to Veritone or that are otherwise uploaded to or captured by the Platform through Licensee's use of the Platform and Services to provide the Services and perform its obligations under this Agreement, directly or through its third party service providers, and (ii) to share such Licensee Content with Veritone's third party service providers solely as required for Veritone's provision of the Platform and Services to Licensee.

5.3. Data Security and Destruction. Veritone will maintain and use adequate administrative, physical, and technical safeguards for protection of the security, confidentiality and integrity of all Licensee Content uploaded to or transmitted through the Platform or Services. Licensee Content shall be used and stored by Veritone solely to the extent required to provide the Services and perform its obligations under this Agreement or as otherwise expressly provided in the License Agreement, and Veritone shall not use or store the Licensee Content for any other purpose whatsoever. Upon termination of this Agreement or upon the written request of Licensee at any time, Veritone shall ensure the secure deletion and destruction of all Licensee Content.

6. Feedback. During the Term, Licensee may provide Veritone with such written evaluations, comments and/or suggestions (collectively, "**Feedback**") regarding the Platform or Services. Licensee acknowledges and agrees that any Feedback provided to Veritone by Licensee hereunder shall be deemed to be Veritone Property and Licensee hereby assigns all right, title and interest in and to such Feedback to Veritone and acknowledges that Veritone will be entitled to, without limitation, implement and exploit any such Feedback in any manner without any restriction or obligation. Notwithstanding the foregoing, Licensee acknowledges that Veritone is not obligated to act on any such Feedback.

7. Term and Termination.

7.1. Term. The term of this Agreement and the License shall be as set forth in the License Agreement (the "**Term**").

7.2. Termination. In addition to any termination rights expressly provided in the License Agreement, this Agreement may be terminated by either party if the other party (i) materially breaches any provision of this Agreement which remains uncured for a period of fourteen (14) days from the date of written notice of such breach; or (ii) makes an assignment for the benefit of its creditors, is declared insolvent, or has a receiver or trustee in bankruptcy appointed to take charge of all or part of such party's property.

7.3. Effect of Termination. If at any time this Agreement is terminated, or upon expiration of the Term, the License and all other rights granted to Licensee herein shall automatically terminate and Licensee shall immediately cease using the Platform and Services.

7.4. Survival. The provisions of Sections 2.2 (Reservation of Rights), 4 (Intellectual Property), 6 (Feedback), 7.3 (Effect of Termination), 8.1 (Fees and Payments), 8.2 (Taxes), 10 (Confidentiality), 11 (Indemnification), 12.2 and 12.3 (Warranty and Disclaimers), 13 (Limitation of Liability), 14 (Miscellaneous) hereof and the payment terms of License Agreement, as applicable, shall survive the expiration or any early termination of this Agreement for any reason.

8. Fees, Charges and Payments.

8.1. Fees and Payments. In consideration for the License and Licensee's access and use of the Platform and Services, Licensee shall pay the license fees, and any applicable additional fees, as set forth in the License Agreement (collectively, the "Fees"). All Fees and other amounts due under this Agreement are payable in U.S. dollars.

8.2. Taxes. All Fees and any other amounts due hereunder are exclusive of taxes and similar assessments which may be imposed on the delivery of the Platform and Services and any other transactions contemplated hereby. Licensee shall be solely responsible for the payment of any and all sales, use, value added, excise, import, or other similar taxes or payments in lieu thereof, including interest and penalties thereon, imposed by any authority, government or governmental agency arising out of or in connection with amounts due hereunder (other than those levied on Veritone's income), and Licensee shall make such payments, and timely file any return or information required by treaty, law, rule or regulation. Upon request, Licensee shall provide Veritone with documentation evidencing such payments. If Veritone is required to pay any such taxes, duties or fees, Licensee shall reimburse Veritone immediately upon receipt of Veritone's invoice thereof.

8.3. Suspension of Platform Access. In addition to Veritone's termination rights set forth herein and without prejudice to any other rights of Veritone at law or in equity, Veritone may suspend its performance under this Agreement and any other agreement with Licensee and Licensee's access to the Platform if Licensee fails to comply with any part of its payment obligations set forth herein. Such suspension of service shall not suspend or otherwise affect Licensee's payment obligations set forth herein.

9. Changes to Platform, Service and Fees. Veritone may, from time to time, in its sole discretion, make changes to the Platform and Services, or a portion thereof including, without limitation, formats, content, reports, functionality, and/or techniques ("Service Change"). In the event of a Service Change, Veritone may, adjust the Fees for the Platform and Services ("Fee Change") in writing. Such Fee Change shall become effective on the date stated in Veritone's notice to Licensee unless, within fifteen (15) days after a Fee Change notice that would result in an increase in the Fees, Licensee notifies Veritone in writing of its refusal to accept the Fee Change, in which event the applicable License to Licensee shall terminate as of the effective date of the change; provided, however, that if the Fee Change is an increase in the Fees, Veritone may, in its sole discretion, elect to rescind the Fee Change, in which case the Platform and Services, as changed, shall continue as provided herein.

10. Confidentiality.

10.1. Confidential Information. Each party (a receiving party) acknowledges and agrees that during the Term and in the course of using the Platform and Services and performing its duties under this Agreement, it may obtain information relating to the other party (a disclosing party), its and/or its customers', vendors', or third party service providers' business or technologies, which is of a confidential and proprietary nature ("**Confidential Information**"). Such Confidential Information may include, but is not limited to, trade secrets, know-how, inventions, techniques, processes, software, algorithms, programs, schematics, data, technology roadmap, sales and marketing plans, and any other information which the receiving party knows or has reason to know is, or which by its nature would reasonably be considered to be, confidential, proprietary or trade secret information of the other party. Without limiting the foregoing, Confidential Information of Veritone shall include the Platform, Services and all associated software and documentation, as well as Feedback or any results of the evaluation or testing of the Platform or Services. The receiving party shall at all times, both during the Term and for a period of three (3) years after its termination (or, in the case of the Platform, Services and any associated software or trade secrets, in perpetuity), keep in trust and confidence all Confidential Information of the disclosing party, and shall not (i) use such Confidential Information other than as expressly authorized under this Agreement or as required for the receiving party to perform its obligations under this Agreement, or (ii) disclose any Confidential Information of the disclosing party to third parties (other than to Veritone's third party service providers in connection with the performance of its obligations under this Agreement), without the disclosing party's prior written consent. The receiving party further agrees to immediately return to the disclosing party or destroy all Confidential Information (including all copies, extracts and summaries thereof) in the receiving party's possession, custody, or control upon the expiration or any termination of this Agreement. The obligations of confidentiality shall not apply to information which (a) has entered the public domain except where such entry is the result of the receiving party's breach of this Agreement; (b) prior to disclosure hereunder, was already in the receiving party's possession and not subject to any confidentiality obligations, as demonstrated by written evidence; (c) subsequent to disclosure hereunder is obtained by the receiving party on a non-confidential basis from a third party who has the right to disclose such information to the receiving party; or (d) has been independently developed by the receiving party without use of or reference to the disclosing party's Confidential Information, as demonstrated by written evidence.

10.2. Permitted Disclosures. The receiving party may make disclosures (i) as required by applicable law or the rules of an stock exchange on which such party's shares are then traded; or (ii) as compelled by court order issued by a court of competent

jurisdiction provided that the receiving party subject to such court order (a) provides the disclosing party with prompt written notice of any such compelled disclosure, (b) uses diligent reasonable efforts to limit disclosure, (c) uses commercially reasonable efforts to obtain confidential treatment or a protective order in connection with the information subject to such compelled disclosure, and (d) allows the disclosing party to participate in any such proceeding.

11. Indemnification.

11.1. Licensee Indemnification of Veritone. Licensee will defend, indemnify and hold harmless Veritone and its subsidiaries, affiliates, successors, assigns, licensors, and their respective members, officers, directors, employees, licensors, agents, from and against any liability or expense, including, without limitation, any expenses, losses, damages, judgments, litigation costs and reasonable attorneys' fees, that Veritone may incur as a result of any claim, suit or proceeding brought against Veritone by any third party arising or resulting from (a) Licensee's breach of any representation, warranty, covenant or obligation contained in this Agreement; or (b) Licensee's use of the Platform or Services (including uploading, using, publishing, posting or otherwise sharing of Licensee's Content or any other data or content derived from the Platform or Services) in any manner that violates this Agreement or any laws, rules, regulations or third party terms and conditions, or that misappropriates or infringes the rights (including Intellectual Property Rights) of any third party; *provided that* Veritone gives Licensee prompt notice of any such claims, cooperates with Licensee in responding to such claims, and permits Licensee to control the defense or settlement of such claims, subject to Veritone's right to (i) conduct the defense of such claims at Veritone's expense, or participate in the defense of such claims with its own counsel at its own expense, and (ii) approve any settlement that binds or purports to bind Veritone.

11.2. Veritone Indemnification of Licensee. Veritone will defend, indemnify and hold harmless Licensee and its subsidiaries, affiliates, successors, assigns, licensors, and their respective members, officers, directors, employees, licensors, agents, from and against any liability or expense, including without limitation, any expenses, losses, damages, judgments, litigation costs and reasonable attorneys' fees that Licensee may incur as a result of any claim, suit or proceeding brought against Licensee by any third party arising or resulting from (a) Veritone's breach of any representation, warranty, covenant or obligation contained in this Agreement; or (b) any allegation that the Platform or Services, or any part thereof, misappropriates or infringes upon any third party's Intellectual Property Rights, except to the extent such claims arise from Licensee's negligence, misconduct or violation of any terms of this Agreement; *provided that* Licensee gives Veritone prompt notice of any such claims, cooperates with Veritone in responding to such claims, and permits Veritone to control the defense or settlement of such claims, subject to Licensee's right to (i) conduct the defense of such claims at Licensee's expense, or participate in the defense of such claims with its own counsel at its own expense, and (ii) approve any settlement that binds or purports to bind Licensee. If the Platform, in whole in part, becomes or, in Veritone's opinion is likely to become, the subject of an infringement claim or action, Veritone may, at its option: (x) procure, at no cost to Licensee, the right for Licensee to continue using the Platform; (y) replace or modify the Platform to render the Platform non-infringing, provided there is no material loss of functionality; or (z) if, in Veritone's reasonable opinion, neither (x) nor (y) above is commercially feasible, terminate this Agreement and refund any prepaid amounts for unused Services during the terminated portion of the Term. The foregoing states Veritone's sole obligation and Licensee's exclusive remedy in the event any such infringement claim or action is commenced or is likely to be commenced.

12. Warranties and Disclaimers.

12.1. Mutual Warranties. Each party represents and warrants to the other that: (i) it is duly organized and validly existing under the laws of the jurisdiction of its incorporation or formation, and has full power, rights and authority to enter into this Agreement and carry out its obligations hereunder; (ii) the person executing this Agreement is authorized to do so on its behalf; (iii) this Agreement is valid and legally binding upon it and (iv) the execution, delivery and performance thereof by such party does not conflict with any other agreement, instrument or understanding to which it is a party or by which it may be bound, nor would violate any applicable law or regulation.

12.2. Disclaimer. THE PLATFORM, SERVICES AND ANY OTHER VERITONE PRODUCTS AND SERVICES ARE PROVIDED ON AN "AS IS" AND "AS AVAILABLE" BASIS. EXCEPT AS EXPRESSLY PROVIDED IN THIS AGREEMENT, VERITONE MAKES NO WARRANTY, EXPRESS OR IMPLIED, WITH RESPECT TO THE PLATFORM AND SERVICES, INCLUDING, WITHOUT LIMITATION, ANY WARRANTY AS TO THE ACCURACY OF PROCESSING RESULTS, ANY WARRANTY OF MERCHANTABILITY, QUALITY OR FITNESS FOR A PARTICULAR PURPOSE, WARRANTIES ARISING FROM COURSE OF DEALING OR USAGE OF TRADE, AND WARRANTIES OF NON-INFRINGEMENT. VERITONE DOES NOT WARRANT THAT THE PLATFORM AND SERVICES ARE ERROR-FREE, WILL RUN UNINTERRUPTED, OR THAT ALL ERRORS CAN OR WILL BE CORRECTED. NO ADVICE OR INFORMATION, WHETHER ORAL OR WRITTEN, OBTAINED BY LICENSEE FROM VERITONE SHALL CREATE ANY SUCH WARRANTY.

12.3. LICENSEE ACKNOWLEDGES AND AGREES THAT THE INTERNET IS A PUBLIC NETWORK OVER WHICH VERITONE EXERTS NO CONTROL. VERITONE MAKES NO REPRESENTATIONS OR WARRANTIES WHATSOEVER, AND SHALL HAVE NO LIABILITY WHATSOEVER, WITH RESPECT TO THE ACCURACY, DEPENDABILITY, PRIVACY, SECURITY, AUTHENTICITY OR COMPLETENESS OF DATA TRANSMITTED OVER OR OBTAINED USING THE INTERNET OUTSIDE OF THOSE SYSTEMS AND NETWORKS CONTROLLED BY VERITONE, OR ANY INTRUSION, VIRUS, DISRUPTION, LOSS OF COMMUNICATION, LOSS OR CORRUPTION OF DATA, OR OTHER ERROR OR EVENT CAUSED OR PERMITTED BY OR INTRODUCED THROUGH LICENSEE'S OWN USE OF THE INTERNET. LICENSEE IS SOLELY RESPONSIBLE FOR IMPLEMENTING ADEQUATE FIREWALL, PASSWORD AND OTHER SECURITY MEASURES TO PROTECT ITS SYSTEMS, DATA AND APPLICATIONS FROM UNWANTED INTRUSION, WHETHER OVER THE INTERNET OR BY OTHER MEANS.

13. Limitation of Liability.

13.1. EXCEPT FOR (A) BREACHES OF EACH PARTY'S OBLIGATIONS UNDER SECTION 10 (CONFIDENTIALITY), AND (B) AMOUNTS FINALLY AWARDED OR SETTLED IN A THIRD PARTY CLAIM FOR WHICH A PARTY IS RESPONSIBLE UNDER SECTION 11 (INDEMNIFICATION), NEITHER PARTY, INCLUDING ITS OFFICERS, DIRECTORS, EMPLOYEES, REPRESENTATIVES AND AFFILIATES, SHALL BE LIABLE FOR ANY INDIRECT, INCIDENTAL, SPECIAL, CONSEQUENTIAL, OR PUNITIVE DAMAGES, INCLUDING WITHOUT LIMITATION, LOST DATA OR LOST PROFITS, OR COSTS OF PROCURING SUBSTITUTE GOODS OR SERVICES, HOWEVER ARISING, EVEN IF IT HAS BEEN ADVISED OF THE POSSIBILITY OF SUCH DAMAGES.

13.2. EXCEPT WITH RESPECT TO EACH PARTY'S CONFIDENTIALITY AND INDEMNIFICATION OBLIGATIONS HEREUNDER, NEITHER PARTY'S LIABILITY FOR DAMAGES ARISING OUT OF, RELATING TO OR IN ANY WAY CONNECTED WITH THIS AGREEMENT SHALL EXCEED THE TOTAL FEES PAID BY LICENSEE TO VERITONE UNDER THIS AGREEMENT.

14. MISCELLANEOUS

14.1. No Assignment. Neither party may assign any of its rights or obligations under this Agreement without the prior written consent of the other party, except that either party may assign its rights and obligations under this Agreement without the consent of the other party to an affiliate directly or indirectly controlling, controlled by, or under direct or indirect common control with such party or in connection with any merger (by operation of law or otherwise), consolidation, reorganization, change in control or sale of all or substantially all of its assets related to this Agreement or similar transaction. This Agreement inures to the benefit of and shall be binding on the parties' permitted assignees, transferees and successors.

14.2. Severability. If any provision of this Agreement is found by a court of competent jurisdiction to be invalid, the parties nevertheless agree that the court should endeavor to give effect to the parties' intentions as reflected in such provision, and the other provisions of this Agreement remain in full force and effect.

14.3. No Waiver. The failure of either party to exercise or enforce any right or provision of this Agreement shall not constitute a waiver of such right or provision.

14.4. Controlling Law. This Agreement shall be governed by and construed in accordance with the laws of the State of California (other than the conflict of law rules) and subject to the sole jurisdiction of the courts sitting in Orange County, California. Notwithstanding the foregoing, nothing in this Section 14.4 shall be deemed to limit the parties' rights to seek injunctive relief in any other court of law of competent jurisdiction.

14.5. Independent Contractors. This Agreement does not create any relationship other than Veritone as an independent contractor performing services covered by this Agreement and Licensee as the party contracting with Veritone for those services. No party is a partner or a legal representative of the other for any purpose whatsoever, nor is any party authorized to make any contract, agreement or warranty on behalf of any other party. Under no circumstance shall one party's employees be construed to be employees of the other party.

14.6. Publicity. Except as required or compelled by applicable law, the rules of any stock exchange, or a court order issued by a court of competent jurisdiction, neither party will make any public statement regarding, or disclose, advertise or publish the terms and conditions of this Agreement without the prior written consent of the other party; provided, however, that Veritone may reference Licensee on Veritone's website, other marketing materials, investor relations materials, and as a customer in Veritone's SEC filings.

14.7. Notices. All notices to either party shall be in writing and delivered by hand or by certified mail or overnight delivery service to the address set forth by Licensee and/or Veritone in the License Agreement, or to such other address as either party shall provide by notice to the other party. Alternatively, the parties may, at their election, utilize email as the method of delivery of any such notice to be provided hereunder. Any such notices sent by email shall be delivered to the email addresses set forth in the License Agreement, or such other email address as designed by a party during the Term. Notices shall be deemed effective when delivered to the applicable address, unless any such notice is sent by

email, in which event, notice shall be deemed effective upon confirmation of delivery by a “read receipt” or other such notice generated by the applicable email system, but in any event, by reply of the recipient of such notice.

- 14.8. Electronic Communication.** In connection with its use of the Platform and Services, Licensee consents to receiving communications from Veritone electronically. Veritone will communicate with Licensee by e-mail or by posting notices on the Platform or through any Services. Licensee agrees that all notices, disclosures and other communications that Veritone provides to Licensee electronically satisfy any legal requirement that such communications be in writing.
- 14.9. Force Majeure.** Except for the obligation to make payments of any Fees or any other amounts due hereunder, neither party will be liable for any failure or delay in its performance under the Agreement due to any cause beyond such party’s control including acts of war, terrorism, acts of God, embargo, riot, sabotage, labor shortage or dispute, governmental act, or failure of the Internet, or any component comprising or operating the network infrastructure thereof (each, a “**Force Majeure Event**”), provided that the delayed party: (i) gives the other party prompt notice of such cause, and (ii) uses its reasonable commercial efforts to promptly correct such failure or delay in performance. If Veritone is unable to provide Service(s) for a period of sixty (60) consecutive days as a result of a continuing Force Majeure Event, either party may elect to terminate this Agreement.
- 14.10. Construction.** This Agreement shall be fairly interpreted and construed in accordance with its terms and without strict interpretation or construction in favor of or against either party. Each party has had the opportunity to consult with counsel in the negotiation of this Agreement.
- 14.11. Counterparts.** This Agreement may be executed in one or more counterparts (including fax or email) each of which shall be deemed an original but all of which taken together shall be deemed one and the same instrument.
- 14.12. Headings.** Unless otherwise expressly stated in this Agreement, the words “herein,” “hereof,” “hereto,” and “hereunder” and other words of similar import refer to this Agreement as a whole and not to any particular section, subsection, or other subdivision. The words “include” and “including” shall not be construed or interpreted as terms of limitation. The words “day,” “month,” and “year” mean, respectively, calendar day, calendar month, and calendar year. Section headings are for reference purposes only, and should not be used in the interpretation hereof.
- 14.13. Amendment.** No addendum, waiver, consent, modification, amendment or change of the terms of this Agreement shall bind either party unless in a writing that references this Agreement and is signed by duly authorized representatives of Licensee and Veritone.
- 14.14. Attorney’s Fees.** If any action arises under this Agreement, including, without limitation the interpretation or enforcement of any term of this Agreement, the prevailing party in any such action shall be entitled to recover its reasonable attorney’s fees and related costs.

From: Tom Avery
Sent: Friday, February 15, 2019 6:17 AM PST
To: William Hillyard
Subject: Re: Veritone pilot agreement
Attachments: Irvine PD Data Sharing Addendum (20190214).docx,
Irvine Police Department Trial License Agreement (IDentify) (20190214).docx,
Master License Terms and Conditions (PS Rev 20180907).pdf, image001.png

Bill,

The updated pilot agreement is attached for your departments review. Let me know if you have any questions and have a good weekend.

Tom

From: William Hillyard <whillyard@cityofirvine.org>
Date: Thursday, February 14, 2019 at 12:27 PM
To: Tom Avery <tavery@veritone.com>
Subject: Re: Veritone pilot agreement

Hi Tom. Just checking in on the status of the revised quote?

Hope you're having a good/dry day.

Sent from my iPhone

On Feb 5, 2019, at 2:37 PM, Tom Avery <tavery@veritone.com> wrote:

Copy.

On Tue, Feb 5, 2019, 14:36 William Hillyard <whillyard@cityofirvine.org> wrote:

I just tried to call your cell. **Measure S**
[REDACTED] I'll probably be there for at least an hour.

Sent from my iPhone

On Feb 5, 2019, at 2:19 PM, Tom Avery <tavery@veritone.com> wrote:

I'll be in route to the Starbucks in about 10. Driving time from Irvine.

On Tue, Feb 5, 2019, 14:15 William Hillyard <whillyard@cityofirvine.org> wrote:

I'm around today. **[REDACTED]**
Investigation **[REDACTED]** If
that doesn't work I'll be in tomorrow at 10am. Feel free to call me at **Privacy** **[REDACTED]** anytime.
I'd like to try and get an answer to the LT by late today or tomorrow AM because they have the

command staff meeting tomorrow where they probably want to present the agreement to the Chief.

Thanks,



William Hillyard | Detective | Irvine Police Department
949-724-7085 | 1 Civic Center Plaza, Irvine, CA 92606
whillyard@cityofirvine.org | cityofirvine.org

From: Tom Avery <tavery@veritone.com>
Sent: Tuesday, February 05, 2019 1:46 PM
To: William Hillyard <whillyard@cityofirvine.org>
Subject: Re: FW: Veritone pilot agreement

This was news to me as well. I stopped by HQ but you must be out on assignment. Let me know when you have some time to talk and I'll drop by.

Tom

On Tue, Feb 5, 2019, 12:52 William Hillyard <whillyard@cityofirvine.org> wrote:

Tom,

Can you please see the question below from Lt. Anderson. In the agreement it states the waived fee is \$15,000 per month, is that meant to be per year for the license fee we discussed in the meeting?

Thank you,



William Hillyard | Detective | Irvine Police Department
949-724-7085 | 1 Civic Center Plaza, Irvine, CA 92606
whillyard@cityofirvine.org | cityofirvine.org

From: Mark Anderson <manderson@cityofirvine.org>
Sent: Monday, February 04, 2019 2:18 PM
To: William Hillyard <whillyard@cityofirvine.org>
Subject: FW: Veritone pilot agreement

Hi Sir. In the License Agreement attached it talked about 15,000 per month, but it's waived? Just not clear what that means. Can you take and look at it and explain or reach out to Veritone and ask for an explanation. Thank you

From: William Hillyard
Sent: Thursday, January 31, 2019 8:13 AM
To: Mark Anderson <manderson@cityofirvine.org>
Subject: FW: Veritone pilot agreement

LT,

Attached are the documents for the Pilot Program agreement with Veritone that need Chief Hamel's signature. Here are some brief points regarding the agreements:

- Irvine PD can opt out of the data sharing portion of the software at any time. If we did opt out but continued to use the software the suspect photos would only be compared to our database of known offenders, and no other agencies would have access to our database of booking photos and known offenders.
- The free trial period for the Pilot Program is 90 days, not 60 as was discussed during our meeting with Veritone.
- The initial License Agreement states that we will have (5) user profiles. This is only for the term of the Pilot Program. If we go forward with purchasing the software we will have an unlimited number of user licenses.
- Section 5.3 of the Master License Terms and Conditions states that if we cancel our relationship with Veritone any data we have provided them is removed from their servers and deleted. There are several portions throughout the agreements which clearly spell out that the data provided by Irvine PD remains the property of Irvine PD and should we terminated our contract with them they have no rights to retain or continue to use any data we provided them.
- The data we are providing other agencies access to through Veritone is no different than the data we upload to Coplink on a daily basis.
- For the Pilot Program we will provide Veritone with an initial data dump of our current database of booking photos, if we go forward with purchasing the software Veritone can set up and automated upload of new booking photos so there is no additional workload for our personnel.

I spoke with Nick Rycroft Monday reference the IT portion of it and he stated when the agreement is signed by the Chief he would begin working on the data export as requested by Veritone.

Please let me know if can provide any additional information.

Thank you,

Bill Hillyard

Begin forwarded message:

From: Tom Avery <tavery@veritone.com>
Date: January 30, 2019 at 7:15:09 AM PST
To: William Hillyard <whillyard@cityofirvine.org>
Subject: Veritone pilot agreement

Bill,

Attached is the Veritone pilot agreement documents which also include the terms and conditions as well as the data sharing agreement. Let me know if you have any questions.

Thanks,
Tom

Tom Avery
Vice President Public Safety
Veritone Government
tavery@veritone.com

Privacy cell

**Veritone IDentify Application
Data Sharing Addendum**

This Data Sharing Addendum (“Addendum”) is entered into as of February __, 2019, by and between Veritone, Inc. (“Veritone”) and Irvine Police Department (“Licensee”). This Addendum is incorporated by reference into, made a part of and governed by the terms of the Pilot Evaluation License Agreement dated February __, 2019 between Veritone and Licensee (the “Agreement”). In the event of any conflict or inconsistency between the provisions contained in the Agreement and the provisions contained in this Addendum with respect to the subject matter hereof, the provisions of this Addendum shall govern and control. Capitalized terms used but not defined herein shall have the meanings ascribed to them in the Agreement.

1. **IDentify Application.** Veritone has granted to Licensee a right and license to access and use the IDentify Application within the Platform. The IDentify Application allows users to upload booking, arrest and known offender databases (collectively, “Booking Databases”) and use facial recognition technology to compare digital evidence from crime scenes with the Booking Databases to identify potential suspects. The IDentify Application also allows Licensee and other judicial and law enforcement agencies (each, an “Agency”) to elect to share access to their Booking Databases as further described in this Addendum (the “Data Sharing Option”).
2. **Participation in Data Sharing Option.** By executing this Addendum, Licensee hereby elects to participate in the Data Sharing Option, and each of Licensee and Veritone acknowledges and agrees to the supplemental terms and conditions applicable to the Data Sharing Option as set forth in this Addendum, in addition to the terms of the Agreement. All rights granted by each party under this Addendum shall continue during the Term of the Agreement, unless earlier terminated as set forth herein.
3. **Databases.**
 - (a) **Shared Databases.** Licensee will participate in the Data Sharing Option with respect to the Booking Databases indicated below (the option indicated below referred to hereinafter as the “Shared Databases”) (*check/complete one option*):
 - The Booking Databases maintained in the Platform by all other Agencies participating in the Data Sharing Option; or
 - The Booking Databases maintained in the Platform by the following Agencies:
 1. N/A
 - 2.
 - 3.
 - 4.
 - (b) **Access to Licensee Databases.** Licensee hereby grants to Veritone the right to grant access to all Booking Databases that Licensee maintains in the Platform (the “Licensee Databases”) to each other Agency that is participating in the Data Sharing Option and is maintaining a Shared Database in the Platform for use by each such Agency in connection with its use of the IDentify Application, and to other Agencies under limited trial licenses for evaluation purposes.
 - (c) **Access to Shared Databases.** Veritone will make available through the IDentify Application, and hereby grants to Licensee the right to access and use, the Shared Databases.
4. **Termination of Participation.** Licensee may terminate its participation in the Data Sharing Option by providing at least 60 days prior written notice to Veritone (or such shorter period as may be required by a court having jurisdiction). In such event, (i) Veritone will restrict access to the Licensee Databases to Licensee only and will terminate access to the Licensee Databases by any other Agency, and (ii) Veritone will terminate Licensee’s access to all Shared Databases, and Licensee’s use of the IDentify Application thereafter will be limited to use with the Licensee Databases only. Licensee acknowledges that Licensee’s right to access and use the Shared Databases is subject at all times to the participation by other Agencies in the Data Sharing Option on a continuous basis. If any Agency terminates its participation in the Data Sharing Option, Licensee will no longer

have access to the Shared Databases of such Agency or to any information generated from the Shared Databases associated with previously run searches and any resulting matches.

5. **Licensee Responsibilities.** Licensee shall be solely responsible for its use of the Shared Databases. Licensee represents and warrants that (a) it will use the Shared Databases solely in conjunction with its use of the IDentify Application in accordance with the terms of this Addendum, and (b) it will use the Shared Databases (including all data, content, materials, information and results contained in and/or generated from any of the foregoing) in compliance with all applicable laws, statutes, ordinances, rules, regulations, consent decrees, and/or requirements of any regulatory authority. Licensee shall defend, indemnify and hold harmless Veritone and its affiliates and licensors, and their respective members, officers, directors, employees, and agents, from and against any liability, losses, damages, judgments, costs and expenses, including litigation costs and reasonable attorneys' fees, arising out of or resulting from Licensee's use of the Shared Databases or Licensee's breach of any of its representations, warranties or obligations set forth in this Addendum.
6. **Authority.** The person executing this Addendum on behalf of each party represents and warrants that he or she has full authority to execute the same on behalf of such party, and that no other actions or approvals are required for such party to enter into this Addendum and perform its obligations hereunder.

IN WITNESS WHEREOF, the parties have caused this Addendum to be executed by their duly authorized representatives as of the date first above written.

VERITONE, INC.

Signature:

Name:

Title:

IRVINE POLICE DEPARTMENT

Signature:

Name:

Title:



PILOT EVALUATION LICENSE AGREEMENT

This Pilot Evaluation License Agreement ("Agreement") is entered into as of the date of the last signature below ("Effective Date") by and between Veritone, Inc. (for itself and/or its subsidiaries), having a principal office located at 575 Anton Boulevard, Suite 100, Costa Mesa, CA 92626 ("Veritone") and the entity listed under Licensee Information below ("Licensee"), with respect to license(s) to Veritone's aiWARE Platform and related Services.

Table with sections: LICENSEE INFORMATION (Agency Name, Address, Contact Name, Phone, Email), LICENSE AND SERVICES DETAILS (Term, Start Date, End Date, No. of Users, License Fees, Services, Cognitive Processing), and TERMS AND CONDITIONS.

- 1. Master License Terms and Conditions. This Agreement and Licensee's access to and use of the Platform and Services shall be governed by the Veritone Master License Terms and Conditions attached hereto as Attachment A and incorporated herein by reference (the "Terms and Conditions").
2. Identify Application and Cognitive Processing. During the Term, Veritone will provide Licensee with access to the IDentify Application and the cognitive processing specified above for content uploaded to the Platform by Licensee through the IDentify Application, for purposes of evaluation of the Platform and Services by Licensee.
3. Limitations. Licensee acknowledges that the IDentify Application is intended to be used by Licensee only as a tool to support review of digital evidence in connection with its investigations, and the IDentify Application and the results generated therefrom should not be considered or relied upon as a substitute for Licensee's customary investigative procedures, protocols and/or requirements.
4. Authority. The person executing this Agreement on behalf of each party represents and warrants that he or she has full authority to execute the same on behalf of such party, and that no other actions or approvals are required for such party to enter into this Agreement and perform its obligations hereunder.

Table with 2 columns: VERITONE, INC. and LICENSEE. Rows include Signature, Name, Title, and Date for both parties.

ATTACHMENT A

**VERITONE, INC. MASTER LICENSE TERMS AND CONDITIONS
(PS-Rev 20180907)**

(Attached)

VERITONE, INC.

MASTER LICENSE TERMS AND CONDITIONS

These Master License Terms and Conditions (“Terms and Conditions”) apply to any License Agreement (as defined below) between Veritone, Inc. (or one of its subsidiaries) (“Veritone”) and a licensee (“Licensee”).

- 1. License Agreement; Controlling Terms.** For purposes hereof, “License Agreement” shall mean the written license agreement, or the order form, subscription form, statement of work or other document, including any addenda or exhibits thereto, accepted by Veritone in writing, that evidences the purchase of a license from Veritone by the Licensee (either directly or through an authorized reseller of Veritone) to access and use the Veritone aiWARE Platform (the “Platform”) and associated Services (as defined below). The Platform is an artificial intelligence operating system that delivers near real-time media processing and analytics, enabling users to process, index, organize, manage, search, analyze and share audio, video and other data through a suite of applications and other services (collectively, the “Services”). The specific Services, content, fees and payment terms, number of authorized users, and the term of license shall be as set forth in the License Agreement. The License Agreement may also contain other license-specific terms and conditions. The License Agreement and these Terms and Conditions are collectively referred to herein as this “Agreement.” In the event of any conflict or inconsistency among the terms and conditions set forth in the License Agreement and in these Terms and Conditions, the rights and obligations of the parties shall be interpreted based on the following order of priority: (1) the License Agreement and (2) these Terms and Conditions. This Agreement constitutes the complete and exclusive agreement between the parties with respect to the Platform and Services, superseding and replacing any and all prior agreements, communications, and understandings, both written and oral, regarding such subject matter, and no additional or different provision contained in any purchase order form, order acknowledgment form, invoice or similar form of either party will be effective.
- 2. License, Reservation of Rights, Restrictions.**
 - 2.1. License.** Veritone hereby grants to Licensee, during the Term (as defined in Section 7 below), a non-transferable, non-sublicensable, non-exclusive, revocable license to access and use the Platform and Services, subject to the terms and conditions set forth in this Agreement (the “License”). Licensee agrees to use the Platform and Services only for its internal business purposes in accordance with the terms of this Agreement. For the avoidance of doubt, the Platform and Services and its content may not be displayed publicly; provided that, subject to the provisions of Section 2.4 (Restrictions) and Section 11 (Indemnification) of this Agreement, Licensee may post, publish or otherwise share its owned or licensed content via the Platform for which sharing capabilities are enabled during the Term in accordance with the terms of this Agreement.
 - 2.2. Reservation of Rights.** The Platform and Services are licensed by Veritone to Licensee, and not sold. Licensee acquires only the right to use the Platform and Services in accordance with this Agreement and does not acquire any rights of ownership. Nothing herein shall be construed to transfer any rights, title or ownership of any Veritone or Veritone-licensed software, technology, materials, information or Intellectual Property Rights to Licensee. All right, title and interest (including all Intellectual Property Rights) in and to the Platform and Services shall at all times remain the sole and exclusive property of Veritone and/or its respective licensors and all use thereof shall inure to the benefit of Veritone and/or its respective licensors. Except as expressly set forth in this Agreement, no right or license, express or implied, is granted to Licensee or any third party by estoppel, implication, exhaustion or other doctrine of law, equity or otherwise with respect to any product, service, software, technology, materials, information or Intellectual Property Rights of Veritone or its affiliates or licensors. “**Intellectual Property Rights**” means all forms of proprietary rights, titles, interests, and ownership including patents, patent rights, copyrights, trademarks, trade dresses, trade secrets, know-how, mask works, *droit moral* (moral rights), publicity rights and all similar rights of every type that may exist now or in the future in any jurisdiction, including without limitation all applications and registrations therefore and rights to apply for any of the foregoing.
 - 2.3. Third Party Licenses.** Certain software components of the Platform and Services are supplied pursuant to license agreements from third parties, and Licensee agrees that Licensee’s use of the Platform and Services shall be subject to the provisions of such third party license agreements.
 - 2.4. Restrictions.**
 - 2.4.1. License Restrictions.** Licensee agrees to use the Platform and Services only for lawful purposes and only as expressly authorized under this Agreement. Without limiting the generality of the foregoing, except as expressly authorized hereunder, Licensee agrees that it shall not, directly or indirectly: (i) license, sublicense, sell, resell, rent, lease, transfer, assign, distribute, display or otherwise make the Platform or Services, in whole or in part, including any content or data derived therefrom that is not directly owned by Licensee or for which Licensee has

all necessary rights, available to any third party, or use the Platform or Services to provide services to any third party; (ii) reverse engineer, decompile, disassemble, modify, translate, reconstruct, omit, distort, obscure, copy or create derivative works of all or any portion of the Platform, Services, any underlying software, or any other Veritone Property (as defined below), or otherwise attempt to access the source code of the Platform or Services; (iii) incorporate any portion of the Platform or Services into Licensee's own programs or compile any portion of them in combination with Licensee's own programs; (iv) store or otherwise capture to physical media, or enable a third party to store or capture, the Platform or Services or any portion thereof; (v) permit any persons, other than Licensee's authorized users for which Licensee has procured User IDs pursuant to the License Agreement, to access and use the Platform or Services; (vi) upload or transmit through the Platform or Services any material, content, media or data (collectively, "Licensee Content") with respect to which Licensee does not either own all right, title and interest or have the appropriate license(s) for lawful use, or otherwise violate or infringe upon the intellectual property rights of any third party in Licensee's use of the Platform or Services, including the use or distribution of any data derived from the Platform or Services; or (vii) violate any laws, rules or regulations in connection with its use of the Platform or Services, including any data or content contained in, transmitted through or derived therefrom.

2.4.2. Prohibited Acts. Licensee acknowledges and agrees that Licensee is prohibited from doing any act that may have the effect of undermining the integrity of the Platform, Services, any related computer systems, infrastructure or environment, or the methods by which Veritone provides Services to users. Without limiting the generality of the foregoing, Licensee agrees that it shall not, directly or indirectly: (i) defeat, circumvent or modify any authentication technology or other security measures, controls, limitations, or content or functionality filters contained in or associated with the Platform or Services, or otherwise attempt to access any aspect of the Platform or Services that Licensee has not been granted authorization to access under the License Agreement; (ii) deploy or facilitate the use or deployment of any script, routine, robot, spider, scraper or any other automated means, method or device with respect to Licensee's access and use of the Platform and Services for any purpose, including to access, view, select, or copy in whole or in part, any content, program, functionality of the Platform or Services, or any other proprietary information or trade secret of Veritone that is made available through the Platform or Services; (iii) deploy or facilitate the use or deployment of any program, system, means, method or device, for any purpose that places an unreasonable, unnecessary or excessive demand or load on the Platform, Services, or related hardware and connections, or prohibits, denies or delays access to Services by other users or otherwise threatens the continuous services of Veritone's ISPs, suppliers and vendors; (iv) introduce into the Platform or Services any program, executable file or routine (such as a worm, Trojan horse, cancel-bot, time bomb or virus) irrespective of whether any such program or routine results in detrimental harm to the Platform, Services, or any underlying systems or programs; (v) remove any proprietary notices, labels or marks from the Platform or Services; (vi) establish any direct or deep link or other connection to any specific page or location within the Platform or Services, other than the Platform log-in page; (vii) use or attempt to use another user's account without authorization, or interfere with another user's access to the Platform or Services; or (viii) access or use the Platform or Services to design, develop, build, market or support a competitive product or service.

3. Access and Use. Veritone will enable Licensee to access and use the Platform for the duration of the Term, subject to any early termination of this Agreement in accordance with the terms hereof. Access to the Platform will be through unique log-in credentials assigned to Licensee by Veritone (each, a "User ID"). Licensee shall be given that number of User IDs as specified in the License Agreement. Licensee will provide accurate and complete information in registering its authorized users for account access. Licensee acknowledges and agrees that the log-in credentials assigned hereunder are Confidential Information and may only be used by Licensee and its authorized users to access the Platform in accordance with the terms of this Agreement, and that Licensee will not publish, share, or otherwise enable any third party, directly or indirectly, to access the Platform for any purpose. Licensee further agrees that Licensee is responsible for its and its authorized users' use of the Platform, including use via the User IDs, and for any consequences thereof. Licensee agrees to immediately notify Veritone of any unauthorized or improper use of any log-in credentials of Licensee. All of the rights, obligations, restrictions, representations and warranties related to Licensee's access and use of the Platform under this Agreement shall apply to Licensee and all of Licensee's employees, contractors, consultants, representatives and agents (collectively, "Representatives"). Licensee shall be responsible for all acts and omissions of its Representatives in the performance of this Agreement and for any breach of this Agreement by any of its Representatives.

4. Intellectual Property.

4.1. Veritone Property. As between Veritone and Licensee, Veritone and/or its respective licensors retain all right, title and interest (including Intellectual Property Rights) in and to the Platform and Services, including, but not limited to any

elements, components, content, technology, software, code, documentation, derivative works, revisions, enhancements, modifications, condensations and/or compilations of or relating to the Platform and Services, and any trademarks, brand identifiers, materials and information, which are created, authored, developed, conceived and/or reduced to practice by Veritone and/or its respective licensors, including in connection with Veritone's provision of the Platform and Services to Licensee under this Agreement ("**Veritone Property**").

4.2. Licensee Property. As between Licensee and Veritone, Licensee retains all right, title and interest (including Intellectual Property Rights) in and to the Licensee Content, and any software, technology, trademarks, brand identifiers, materials and information which are independently created, authored, developed, conceived or reduced to practice by Licensee.

5. Licensee Content.

5.1. Content Ownership. Licensee represents and warrants that (i) Licensee and/or its licensors own all right, title and interest in and to all Licensee Content uploaded to or transmitted through the Platform or Services, or otherwise have all rights in such Licensee Content as necessary to use the same in connection with Licensee's use of the Platform and Services, (ii) such Licensee Content does not and will not misappropriate or infringe upon any third party's Intellectual Property Rights, or violate any other rights of any third party, and (iii) Licensee has all rights in such Licensee Content necessary to grant the rights contemplated by this Agreement.

5.2. License to Content. Unless otherwise specified in the License Agreement, Licensee hereby grants to Veritone a non-exclusive, royalty-free, worldwide license (i) to use and display all Licensee Content that Licensee provides to Veritone or that are otherwise uploaded to or captured by the Platform through Licensee's use of the Platform and Services to provide the Services and perform its obligations under this Agreement, directly or through its third party service providers, and (ii) to share such Licensee Content with Veritone's third party service providers solely as required for Veritone's provision of the Platform and Services to Licensee.

5.3. Data Security and Destruction. Veritone will maintain and use adequate administrative, physical, and technical safeguards for protection of the security, confidentiality and integrity of all Licensee Content uploaded to or transmitted through the Platform or Services. Licensee Content shall be used and stored by Veritone solely to the extent required to provide the Services and perform its obligations under this Agreement or as otherwise expressly provided in the License Agreement, and Veritone shall not use or store the Licensee Content for any other purpose whatsoever. Upon termination of this Agreement or upon the written request of Licensee at any time, Veritone shall ensure the secure deletion and destruction of all Licensee Content.

6. Feedback. During the Term, Licensee may provide Veritone with such written evaluations, comments and/or suggestions (collectively, "**Feedback**") regarding the Platform or Services. Licensee acknowledges and agrees that any Feedback provided to Veritone by Licensee hereunder shall be deemed to be Veritone Property and Licensee hereby assigns all right, title and interest in and to such Feedback to Veritone and acknowledges that Veritone will be entitled to, without limitation, implement and exploit any such Feedback in any manner without any restriction or obligation. Notwithstanding the foregoing, Licensee acknowledges that Veritone is not obligated to act on any such Feedback.

7. Term and Termination.

7.1. Term. The term of this Agreement and the License shall be as set forth in the License Agreement (the "**Term**").

7.2. Termination. In addition to any termination rights expressly provided in the License Agreement, this Agreement may be terminated by either party if the other party (i) materially breaches any provision of this Agreement which remains uncured for a period of fourteen (14) days from the date of written notice of such breach; or (ii) makes an assignment for the benefit of its creditors, is declared insolvent, or has a receiver or trustee in bankruptcy appointed to take charge of all or part of such party's property.

7.3. Effect of Termination. If at any time this Agreement is terminated, or upon expiration of the Term, the License and all other rights granted to Licensee herein shall automatically terminate and Licensee shall immediately cease using the Platform and Services.

7.4. Survival. The provisions of Sections 2.2 (Reservation of Rights), 4 (Intellectual Property), 6 (Feedback), 7.3 (Effect of Termination), 8.1 (Fees and Payments), 8.2 (Taxes), 10 (Confidentiality), 11 (Indemnification), 12.2 and 12.3 (Warranty and Disclaimers), 13 (Limitation of Liability), 14 (Miscellaneous) hereof and the payment terms of License Agreement, as applicable, shall survive the expiration or any early termination of this Agreement for any reason.

8. Fees, Charges and Payments.

8.1. Fees and Payments. In consideration for the License and Licensee's access and use of the Platform and Services, Licensee shall pay the license fees, and any applicable additional fees, as set forth in the License Agreement (collectively, the "Fees"). All Fees and other amounts due under this Agreement are payable in U.S. dollars.

8.2. Taxes. All Fees and any other amounts due hereunder are exclusive of taxes and similar assessments which may be imposed on the delivery of the Platform and Services and any other transactions contemplated hereby. Licensee shall be solely responsible for the payment of any and all sales, use, value added, excise, import, or other similar taxes or payments in lieu thereof, including interest and penalties thereon, imposed by any authority, government or governmental agency arising out of or in connection with amounts due hereunder (other than those levied on Veritone's income), and Licensee shall make such payments, and timely file any return or information required by treaty, law, rule or regulation. Upon request, Licensee shall provide Veritone with documentation evidencing such payments. If Veritone is required to pay any such taxes, duties or fees, Licensee shall reimburse Veritone immediately upon receipt of Veritone's invoice thereof.

8.3. Suspension of Platform Access. In addition to Veritone's termination rights set forth herein and without prejudice to any other rights of Veritone at law or in equity, Veritone may suspend its performance under this Agreement and any other agreement with Licensee and Licensee's access to the Platform if Licensee fails to comply with any part of its payment obligations set forth herein. Such suspension of service shall not suspend or otherwise affect Licensee's payment obligations set forth herein.

9. Changes to Platform, Service and Fees. Veritone may, from time to time, in its sole discretion, make changes to the Platform and Services, or a portion thereof including, without limitation, formats, content, reports, functionality, and/or techniques ("Service Change"). In the event of a Service Change, Veritone may, adjust the Fees for the Platform and Services ("Fee Change") in writing. Such Fee Change shall become effective on the date stated in Veritone's notice to Licensee unless, within fifteen (15) days after a Fee Change notice that would result in an increase in the Fees, Licensee notifies Veritone in writing of its refusal to accept the Fee Change, in which event the applicable License to Licensee shall terminate as of the effective date of the change; provided, however, that if the Fee Change is an increase in the Fees, Veritone may, in its sole discretion, elect to rescind the Fee Change, in which case the Platform and Services, as changed, shall continue as provided herein.

10. Confidentiality.

10.1. Confidential Information. Each party (a receiving party) acknowledges and agrees that during the Term and in the course of using the Platform and Services and performing its duties under this Agreement, it may obtain information relating to the other party (a disclosing party), its and/or its customers', vendors', or third party service providers' business or technologies, which is of a confidential and proprietary nature ("**Confidential Information**"). Such Confidential Information may include, but is not limited to, trade secrets, know-how, inventions, techniques, processes, software, algorithms, programs, schematics, data, technology roadmap, sales and marketing plans, and any other information which the receiving party knows or has reason to know is, or which by its nature would reasonably be considered to be, confidential, proprietary or trade secret information of the other party. Without limiting the foregoing, Confidential Information of Veritone shall include the Platform, Services and all associated software and documentation, as well as Feedback or any results of the evaluation or testing of the Platform or Services. The receiving party shall at all times, both during the Term and for a period of three (3) years after its termination (or, in the case of the Platform, Services and any associated software or trade secrets, in perpetuity), keep in trust and confidence all Confidential Information of the disclosing party, and shall not (i) use such Confidential Information other than as expressly authorized under this Agreement or as required for the receiving party to perform its obligations under this Agreement, or (ii) disclose any Confidential Information of the disclosing party to third parties (other than to Veritone's third party service providers in connection with the performance of its obligations under this Agreement), without the disclosing party's prior written consent. The receiving party further agrees to immediately return to the disclosing party or destroy all Confidential Information (including all copies, extracts and summaries thereof) in the receiving party's possession, custody, or control upon the expiration or any termination of this Agreement. The obligations of confidentiality shall not apply to information which (a) has entered the public domain except where such entry is the result of the receiving party's breach of this Agreement; (b) prior to disclosure hereunder, was already in the receiving party's possession and not subject to any confidentiality obligations, as demonstrated by written evidence; (c) subsequent to disclosure hereunder is obtained by the receiving party on a non-confidential basis from a third party who has the right to disclose such information to the receiving party; or (d) has been independently developed by the receiving party without use of or reference to the disclosing party's Confidential Information, as demonstrated by written evidence.

10.2. Permitted Disclosures. The receiving party may make disclosures (i) as required by applicable law or the rules of an stock exchange on which such party's shares are then traded; or (ii) as compelled by court order issued by a court of competent

jurisdiction provided that the receiving party subject to such court order (a) provides the disclosing party with prompt written notice of any such compelled disclosure, (b) uses diligent reasonable efforts to limit disclosure, (c) uses commercially reasonable efforts to obtain confidential treatment or a protective order in connection with the information subject to such compelled disclosure, and (d) allows the disclosing party to participate in any such proceeding.

11. Indemnification.

11.1. Licensee Indemnification of Veritone. Licensee will defend, indemnify and hold harmless Veritone and its subsidiaries, affiliates, successors, assigns, licensors, and their respective members, officers, directors, employees, licensors, agents, from and against any liability or expense, including, without limitation, any expenses, losses, damages, judgments, litigation costs and reasonable attorneys' fees, that Veritone may incur as a result of any claim, suit or proceeding brought against Veritone by any third party arising or resulting from (a) Licensee's breach of any representation, warranty, covenant or obligation contained in this Agreement; or (b) Licensee's use of the Platform or Services (including uploading, using, publishing, posting or otherwise sharing of Licensee's Content or any other data or content derived from the Platform or Services) in any manner that violates this Agreement or any laws, rules, regulations or third party terms and conditions, or that misappropriates or infringes the rights (including Intellectual Property Rights) of any third party; *provided that* Veritone gives Licensee prompt notice of any such claims, cooperates with Licensee in responding to such claims, and permits Licensee to control the defense or settlement of such claims, subject to Veritone's right to (i) conduct the defense of such claims at Veritone's expense, or participate in the defense of such claims with its own counsel at its own expense, and (ii) approve any settlement that binds or purports to bind Veritone.

11.2. Veritone Indemnification of Licensee. Veritone will defend, indemnify and hold harmless Licensee and its subsidiaries, affiliates, successors, assigns, licensors, and their respective members, officers, directors, employees, licensors, agents, from and against any liability or expense, including without limitation, any expenses, losses, damages, judgments, litigation costs and reasonable attorneys' fees that Licensee may incur as a result of any claim, suit or proceeding brought against Licensee by any third party arising or resulting from (a) Veritone's breach of any representation, warranty, covenant or obligation contained in this Agreement; or (b) any allegation that the Platform or Services, or any part thereof, misappropriates or infringes upon any third party's Intellectual Property Rights, except to the extent such claims arise from Licensee's negligence, misconduct or violation of any terms of this Agreement; *provided that* Licensee gives Veritone prompt notice of any such claims, cooperates with Veritone in responding to such claims, and permits Veritone to control the defense or settlement of such claims, subject to Licensee's right to (i) conduct the defense of such claims at Licensee's expense, or participate in the defense of such claims with its own counsel at its own expense, and (ii) approve any settlement that binds or purports to bind Licensee. If the Platform, in whole in part, becomes or, in Veritone's opinion is likely to become, the subject of an infringement claim or action, Veritone may, at its option: (x) procure, at no cost to Licensee, the right for Licensee to continue using the Platform; (y) replace or modify the Platform to render the Platform non-infringing, provided there is no material loss of functionality; or (z) if, in Veritone's reasonable opinion, neither (x) nor (y) above is commercially feasible, terminate this Agreement and refund any prepaid amounts for unused Services during the terminated portion of the Term. The foregoing states Veritone's sole obligation and Licensee's exclusive remedy in the event any such infringement claim or action is commenced or is likely to be commenced.

12. Warranties and Disclaimers.

12.1. Mutual Warranties. Each party represents and warrants to the other that: (i) it is duly organized and validly existing under the laws of the jurisdiction of its incorporation or formation, and has full power, rights and authority to enter into this Agreement and carry out its obligations hereunder; (ii) the person executing this Agreement is authorized to do so on its behalf; (iii) this Agreement is valid and legally binding upon it and (iv) the execution, delivery and performance thereof by such party does not conflict with any other agreement, instrument or understanding to which it is a party or by which it may be bound, nor would violate any applicable law or regulation.

12.2. Disclaimer. THE PLATFORM, SERVICES AND ANY OTHER VERITONE PRODUCTS AND SERVICES ARE PROVIDED ON AN "AS IS" AND "AS AVAILABLE" BASIS. EXCEPT AS EXPRESSLY PROVIDED IN THIS AGREEMENT, VERITONE MAKES NO WARRANTY, EXPRESS OR IMPLIED, WITH RESPECT TO THE PLATFORM AND SERVICES, INCLUDING, WITHOUT LIMITATION, ANY WARRANTY AS TO THE ACCURACY OF PROCESSING RESULTS, ANY WARRANTY OF MERCHANTABILITY, QUALITY OR FITNESS FOR A PARTICULAR PURPOSE, WARRANTIES ARISING FROM COURSE OF DEALING OR USAGE OF TRADE, AND WARRANTIES OF NON-INFRINGEMENT. VERITONE DOES NOT WARRANT THAT THE PLATFORM AND SERVICES ARE ERROR-FREE, WILL RUN UNINTERRUPTED, OR THAT ALL ERRORS CAN OR WILL BE CORRECTED. NO ADVICE OR INFORMATION, WHETHER ORAL OR WRITTEN, OBTAINED BY LICENSEE FROM VERITONE SHALL CREATE ANY SUCH WARRANTY.

12.3. LICENSEE ACKNOWLEDGES AND AGREES THAT THE INTERNET IS A PUBLIC NETWORK OVER WHICH VERITONE EXERTS NO CONTROL. VERITONE MAKES NO REPRESENTATIONS OR WARRANTIES WHATSOEVER, AND SHALL HAVE NO LIABILITY WHATSOEVER, WITH RESPECT TO THE ACCURACY, DEPENDABILITY, PRIVACY, SECURITY, AUTHENTICITY OR COMPLETENESS OF DATA TRANSMITTED OVER OR OBTAINED USING THE INTERNET OUTSIDE OF THOSE SYSTEMS AND NETWORKS CONTROLLED BY VERITONE, OR ANY INTRUSION, VIRUS, DISRUPTION, LOSS OF COMMUNICATION, LOSS OR CORRUPTION OF DATA, OR OTHER ERROR OR EVENT CAUSED OR PERMITTED BY OR INTRODUCED THROUGH LICENSEE'S OWN USE OF THE INTERNET. LICENSEE IS SOLELY RESPONSIBLE FOR IMPLEMENTING ADEQUATE FIREWALL, PASSWORD AND OTHER SECURITY MEASURES TO PROTECT ITS SYSTEMS, DATA AND APPLICATIONS FROM UNWANTED INTRUSION, WHETHER OVER THE INTERNET OR BY OTHER MEANS.

13. Limitation of Liability.

13.1. EXCEPT FOR (A) BREACHES OF EACH PARTY'S OBLIGATIONS UNDER SECTION 10 (CONFIDENTIALITY), AND (B) AMOUNTS FINALLY AWARDED OR SETTLED IN A THIRD PARTY CLAIM FOR WHICH A PARTY IS RESPONSIBLE UNDER SECTION 11 (INDEMNIFICATION), NEITHER PARTY, INCLUDING ITS OFFICERS, DIRECTORS, EMPLOYEES, REPRESENTATIVES AND AFFILIATES, SHALL BE LIABLE FOR ANY INDIRECT, INCIDENTAL, SPECIAL, CONSEQUENTIAL, OR PUNITIVE DAMAGES, INCLUDING WITHOUT LIMITATION, LOST DATA OR LOST PROFITS, OR COSTS OF PROCURING SUBSTITUTE GOODS OR SERVICES, HOWEVER ARISING, EVEN IF IT HAS BEEN ADVISED OF THE POSSIBILITY OF SUCH DAMAGES.

13.2. EXCEPT WITH RESPECT TO EACH PARTY'S CONFIDENTIALITY AND INDEMNIFICATION OBLIGATIONS HEREUNDER, NEITHER PARTY'S LIABILITY FOR DAMAGES ARISING OUT OF, RELATING TO OR IN ANY WAY CONNECTED WITH THIS AGREEMENT SHALL EXCEED THE TOTAL FEES PAID BY LICENSEE TO VERITONE UNDER THIS AGREEMENT.

14. MISCELLANEOUS

14.1. No Assignment. Neither party may assign any of its rights or obligations under this Agreement without the prior written consent of the other party, except that either party may assign its rights and obligations under this Agreement without the consent of the other party to an affiliate directly or indirectly controlling, controlled by, or under direct or indirect common control with such party or in connection with any merger (by operation of law or otherwise), consolidation, reorganization, change in control or sale of all or substantially all of its assets related to this Agreement or similar transaction. This Agreement inures to the benefit of and shall be binding on the parties' permitted assignees, transferees and successors.

14.2. Severability. If any provision of this Agreement is found by a court of competent jurisdiction to be invalid, the parties nevertheless agree that the court should endeavor to give effect to the parties' intentions as reflected in such provision, and the other provisions of this Agreement remain in full force and effect.

14.3. No Waiver. The failure of either party to exercise or enforce any right or provision of this Agreement shall not constitute a waiver of such right or provision.

14.4. Controlling Law. This Agreement shall be governed by and construed in accordance with the laws of the State of California (other than the conflict of law rules) and subject to the sole jurisdiction of the courts sitting in Orange County, California. Notwithstanding the foregoing, nothing in this Section 14.4 shall be deemed to limit the parties' rights to seek injunctive relief in any other court of law of competent jurisdiction.

14.5. Independent Contractors. This Agreement does not create any relationship other than Veritone as an independent contractor performing services covered by this Agreement and Licensee as the party contracting with Veritone for those services. No party is a partner or a legal representative of the other for any purpose whatsoever, nor is any party authorized to make any contract, agreement or warranty on behalf of any other party. Under no circumstance shall one party's employees be construed to be employees of the other party.

14.6. Publicity. Except as required or compelled by applicable law, the rules of any stock exchange, or a court order issued by a court of competent jurisdiction, neither party will make any public statement regarding, or disclose, advertise or publish the terms and conditions of this Agreement without the prior written consent of the other party; provided, however, that Veritone may reference Licensee on Veritone's website, other marketing materials, investor relations materials, and as a customer in Veritone's SEC filings.

14.7. Notices. All notices to either party shall be in writing and delivered by hand or by certified mail or overnight delivery service to the address set forth by Licensee and/or Veritone in the License Agreement, or to such other address as either party shall provide by notice to the other party. Alternatively, the parties may, at their election, utilize email as the method of delivery of any such notice to be provided hereunder. Any such notices sent by email shall be delivered to the email addresses set forth in the License Agreement, or such other email address as designed by a party during the Term. Notices shall be deemed effective when delivered to the applicable address, unless any such notice is sent by

email, in which event, notice shall be deemed effective upon confirmation of delivery by a “read receipt” or other such notice generated by the applicable email system, but in any event, by reply of the recipient of such notice.

- 14.8. Electronic Communication.** In connection with its use of the Platform and Services, Licensee consents to receiving communications from Veritone electronically. Veritone will communicate with Licensee by e-mail or by posting notices on the Platform or through any Services. Licensee agrees that all notices, disclosures and other communications that Veritone provides to Licensee electronically satisfy any legal requirement that such communications be in writing.
- 14.9. Force Majeure.** Except for the obligation to make payments of any Fees or any other amounts due hereunder, neither party will be liable for any failure or delay in its performance under the Agreement due to any cause beyond such party’s control including acts of war, terrorism, acts of God, embargo, riot, sabotage, labor shortage or dispute, governmental act, or failure of the Internet, or any component comprising or operating the network infrastructure thereof (each, a “**Force Majeure Event**”), provided that the delayed party: (i) gives the other party prompt notice of such cause, and (ii) uses its reasonable commercial efforts to promptly correct such failure or delay in performance. If Veritone is unable to provide Service(s) for a period of sixty (60) consecutive days as a result of a continuing Force Majeure Event, either party may elect to terminate this Agreement.
- 14.10. Construction.** This Agreement shall be fairly interpreted and construed in accordance with its terms and without strict interpretation or construction in favor of or against either party. Each party has had the opportunity to consult with counsel in the negotiation of this Agreement.
- 14.11. Counterparts.** This Agreement may be executed in one or more counterparts (including fax or email) each of which shall be deemed an original but all of which taken together shall be deemed one and the same instrument.
- 14.12. Headings.** Unless otherwise expressly stated in this Agreement, the words “herein,” “hereof,” “hereto,” and “hereunder” and other words of similar import refer to this Agreement as a whole and not to any particular section, subsection, or other subdivision. The words “include” and “including” shall not be construed or interpreted as terms of limitation. The words “day,” “month,” and “year” mean, respectively, calendar day, calendar month, and calendar year. Section headings are for reference purposes only, and should not be used in the interpretation hereof.
- 14.13. Amendment.** No addendum, waiver, consent, modification, amendment or change of the terms of this Agreement shall bind either party unless in a writing that references this Agreement and is signed by duly authorized representatives of Licensee and Veritone.
- 14.14. Attorney’s Fees.** If any action arises under this Agreement, including, without limitation the interpretation or enforcement of any term of this Agreement, the prevailing party in any such action shall be entitled to recover its reasonable attorney’s fees and related costs.

From: William Hillyard
Sent: Friday, February 15, 2019 1:48 PM PST
To: Mark Anderson
Subject: FW: Veritone pilot agreement
Attachments: Irvine PD Data Sharing Addendum (20190214).docx,
Irvine Police Department Trial License Agreement (IDentify) (20190214).docx,
Master License Terms and Conditions (PS Rev 20180907).pdf, image001.png, image002.png

LT,

Here is the revised License Agreement for your review. As we discussed, they have changed the wording, and in fact changed the title of the document all together. The document is now a "Pilot Evaluation License Agreement" with an end date of May 30, 2019. The license fee is "Waived for pilot evaluation" and there is no mention anywhere in any of the new documentation of a cost for an ongoing license for the software if we decided to move forward with making a purchase. As we've talked about, not having any idea of a pricing structure is not ideal, but I don't believe even at this point that Veritone themselves have any clue what to charge for an annual license for this software. The agreement we would be signing here is the same agreement Station 18 and Anaheim PD are operating under.

Please let me know if you have any question regarding the new documents.

Thank you,



William Hillyard | Detective | Irvine Police Department
949-724-7085 | 1 Civic Center Plaza, Irvine, CA 92606
whillyard@cityofirvine.org | cityofirvine.org

From: Tom Avery <tavery@veritone.com>
Sent: Friday, February 15, 2019 6:17 AM
To: William Hillyard <whillyard@cityofirvine.org>
Subject: Re: Veritone pilot agreement

Bill,

The updated pilot agreement is attached for your departments review. Let me know if you have any questions and have a good weekend.

Tom

From: William Hillyard <whillyard@cityofirvine.org>
Date: Thursday, February 14, 2019 at 12:27 PM
To: Tom Avery <tavery@veritone.com>
Subject: Re: Veritone pilot agreement

Hi Tom. Just checking in on the status of the revised quote?

Hope you're having a good/dry day.

Sent from my iPhone

On Feb 5, 2019, at 2:37 PM, Tom Avery <tavery@veritone.com> wrote:

Copy.

On Tue, Feb 5, 2019, 14:36 William Hillyard <whillyard@cityofirvine.org> wrote:

I just tried to call your cell. Measure S

I'll probably be there for at least an hour.

Sent from my iPhone

On Feb 5, 2019, at 2:19 PM, Tom Avery <tavery@veritone.com> wrote:

I'll be in route to the Starbucks in about 10. Driving time from Irvine.

On Tue, Feb 5, 2019, 14:15 William Hillyard <whillyard@cityofirvine.org> wrote:

I'm around today.

Investigation

that doesn't work I'll be in tomorrow at 10am. Feel free to call me at Privacy anytime.

I'd like to try and get an answer to the LT by late today or tomorrow AM because they have the command staff meeting tomorrow where they probably want to present the agreement to the Chief.

Thanks,



William Hillyard | Detective | Irvine Police Department
949-724-7085 | 1 Civic Center Plaza, Irvine, CA 92606
whillyard@cityofirvine.org | cityofirvine.org

From: Tom Avery <tavery@veritone.com>
Sent: Tuesday, February 05, 2019 1:46 PM
To: William Hillyard <whillyard@cityofirvine.org>
Subject: Re: FW: Veritone pilot agreement

This was news to me as well. I stopped by HQ but you must be out on assignment. Let me know when you have some time to talk and I'll drop by.

Tom

On Tue, Feb 5, 2019, 12:52 William Hillyard <whillyard@cityofirvine.org> wrote:

Tom,

Can you please see the question below from Lt. Anderson. In the agreement it states the waived fee is \$15,000 per month, is that meant to be per year for the license fee we discussed in the meeting?

Thank you,



William Hillyard | Detective | Irvine Police Department
949-724-7085 | 1 Civic Center Plaza, Irvine, CA 92606
whillyard@cityofirvine.org | cityofirvine.org

From: Mark Anderson <manderson@cityofirvine.org>
Sent: Monday, February 04, 2019 2:18 PM
To: William Hillyard <whillyard@cityofirvine.org>
Subject: FW: Veritone pilot agreement

Hi Sir. In the License Agreement attached it talked about 15,000 per month, but it's waived? Just not clear what that means. Can you take and look at it and explain or reach out to Veritone and ask for an explanation. Thank you

From: William Hillyard
Sent: Thursday, January 31, 2019 8:13 AM
To: Mark Anderson <manderson@cityofirvine.org>
Subject: FW: Veritone pilot agreement

LT,

Attached are the documents for the Pilot Program agreement with Veritone that need Chief Hamel's signature. Here are some brief points regarding the agreements:

- Irvine PD can opt out of the data sharing portion of the software at any time. If we did opt out but continued to use the software the suspect photos would only be compared to our database of known offenders, and no other agencies would have access to our database of booking photos and known offenders.
- The free trial period for the Pilot Program is 90 days, not 60 as was discussed during our meeting with Veritone.
- The initial License Agreement states that we will have (5) user profiles. This is only for the term of the Pilot Program. If we go forward with purchasing the software we will have an unlimited number of user licenses.

- Section 5.3 of the Master License Terms and Conditions states that if we cancel our relationship with Veritone any data we have provided them is removed from their servers and deleted. There are several portions throughout the agreements which clearly spell out that the data provided by Irvine PD remains the property of Irvine PD and should we terminated our contract with them they have no rights to retain or continue to use any data we provided them.
- The data we are providing other agencies access to through Veritone is no different than the data we upload to Coplink on a daily basis.
- For the Pilot Program we will provide Veritone with an initial data dump of our current database of booking photos, if we go forward with purchasing the software Veritone can set up and automated upload of new booking photos so there is no additional workload for our personnel.

I spoke with Nick Rycroft Monday reference the IT portion of it and he stated when the agreement is signed by the Chief he would begin working on the data export as requested by Veritone.

Please let me know if can provide any additional information.

Thank you,

Bill Hillyard

Begin forwarded message:

From: Tom Avery <tavery@veritone.com>
Date: January 30, 2019 at 7:15:09 AM PST
To: William Hillyard <whillyard@cityofirvine.org>
Subject: Veritone pilot agreement

Bill,

Attached is the Veritone pilot agreement documents which also include the terms and conditions as well as the data sharing agreement. Let me know if you have any questions.

Thanks,
Tom

Tom Avery
Vice President Public Safety
Veritone Government
tavery@veritone.com

Privacy cell

**Veritone IDentify Application
Data Sharing Addendum**

This Data Sharing Addendum (“Addendum”) is entered into as of February __, 2019, by and between Veritone, Inc. (“Veritone”) and Irvine Police Department (“Licensee”). This Addendum is incorporated by reference into, made a part of and governed by the terms of the Pilot Evaluation License Agreement dated February __, 2019 between Veritone and Licensee (the “Agreement”). In the event of any conflict or inconsistency between the provisions contained in the Agreement and the provisions contained in this Addendum with respect to the subject matter hereof, the provisions of this Addendum shall govern and control. Capitalized terms used but not defined herein shall have the meanings ascribed to them in the Agreement.

1. **IDentify Application.** Veritone has granted to Licensee a right and license to access and use the IDentify Application within the Platform. The IDentify Application allows users to upload booking, arrest and known offender databases (collectively, “Booking Databases”) and use facial recognition technology to compare digital evidence from crime scenes with the Booking Databases to identify potential suspects. The IDentify Application also allows Licensee and other judicial and law enforcement agencies (each, an “Agency”) to elect to share access to their Booking Databases as further described in this Addendum (the “Data Sharing Option”).
2. **Participation in Data Sharing Option.** By executing this Addendum, Licensee hereby elects to participate in the Data Sharing Option, and each of Licensee and Veritone acknowledges and agrees to the supplemental terms and conditions applicable to the Data Sharing Option as set forth in this Addendum, in addition to the terms of the Agreement. All rights granted by each party under this Addendum shall continue during the Term of the Agreement, unless earlier terminated as set forth herein.
3. **Databases.**
 - (a) **Shared Databases.** Licensee will participate in the Data Sharing Option with respect to the Booking Databases indicated below (the option indicated below referred to hereinafter as the “Shared Databases”) (*check/complete one option*):
 - The Booking Databases maintained in the Platform by all other Agencies participating in the Data Sharing Option; or
 - The Booking Databases maintained in the Platform by the following Agencies:
 1. N/A
 - 2.
 - 3.
 - 4.
 - (b) **Access to Licensee Databases.** Licensee hereby grants to Veritone the right to grant access to all Booking Databases that Licensee maintains in the Platform (the “Licensee Databases”) to each other Agency that is participating in the Data Sharing Option and is maintaining a Shared Database in the Platform for use by each such Agency in connection with its use of the IDentify Application, and to other Agencies under limited trial licenses for evaluation purposes.
 - (c) **Access to Shared Databases.** Veritone will make available through the IDentify Application, and hereby grants to Licensee the right to access and use, the Shared Databases.
4. **Termination of Participation.** Licensee may terminate its participation in the Data Sharing Option by providing at least 60 days prior written notice to Veritone (or such shorter period as may be required by a court having jurisdiction). In such event, (i) Veritone will restrict access to the Licensee Databases to Licensee only and will terminate access to the Licensee Databases by any other Agency, and (ii) Veritone will terminate Licensee’s access to all Shared Databases, and Licensee’s use of the IDentify Application thereafter will be limited to use with the Licensee Databases only. Licensee acknowledges that Licensee’s right to access and use the Shared Databases is subject at all times to the participation by other Agencies in the Data Sharing Option on a continuous basis. If any Agency terminates its participation in the Data Sharing Option, Licensee will no longer

have access to the Shared Databases of such Agency or to any information generated from the Shared Databases associated with previously run searches and any resulting matches.

5. **Licensee Responsibilities.** Licensee shall be solely responsible for its use of the Shared Databases. Licensee represents and warrants that (a) it will use the Shared Databases solely in conjunction with its use of the IDentify Application in accordance with the terms of this Addendum, and (b) it will use the Shared Databases (including all data, content, materials, information and results contained in and/or generated from any of the foregoing) in compliance with all applicable laws, statutes, ordinances, rules, regulations, consent decrees, and/or requirements of any regulatory authority. Licensee shall defend, indemnify and hold harmless Veritone and its affiliates and licensors, and their respective members, officers, directors, employees, and agents, from and against any liability, losses, damages, judgments, costs and expenses, including litigation costs and reasonable attorneys' fees, arising out of or resulting from Licensee's use of the Shared Databases or Licensee's breach of any of its representations, warranties or obligations set forth in this Addendum.
6. **Authority.** The person executing this Addendum on behalf of each party represents and warrants that he or she has full authority to execute the same on behalf of such party, and that no other actions or approvals are required for such party to enter into this Addendum and perform its obligations hereunder.

IN WITNESS WHEREOF, the parties have caused this Addendum to be executed by their duly authorized representatives as of the date first above written.

VERITONE, INC.

Signature:

Name:

Title:

IRVINE POLICE DEPARTMENT

Signature:

Name:

Title:



PILOT EVALUATION LICENSE AGREEMENT

This Pilot Evaluation License Agreement ("Agreement") is entered into as of the date of the last signature below ("Effective Date") by and between Veritone, Inc. (for itself and/or its subsidiaries), having a principal office located at 575 Anton Boulevard, Suite 100, Costa Mesa, CA 92626 ("Veritone") and the entity listed under Licensee Information below ("Licensee"), with respect to license(s) to Veritone's aiWARE Platform and related Services.

Table with sections: LICENSEE INFORMATION (Agency Name, Address, Contact Name, Phone, Email), LICENSE AND SERVICES DETAILS (Term, Start Date, End Date, No. of Users, License Fees, Services, Cognitive Processing), and TERMS AND CONDITIONS.

- 1. Master License Terms and Conditions. This Agreement and Licensee's access to and use of the Platform and Services shall be governed by the Veritone Master License Terms and Conditions attached hereto as Attachment A and incorporated herein by reference (the "Terms and Conditions").
2. Identify Application and Cognitive Processing. During the Term, Veritone will provide Licensee with access to the IDentify Application and the cognitive processing specified above for content uploaded to the Platform by Licensee through the IDentify Application, for purposes of evaluation of the Platform and Services by Licensee.
3. Limitations. Licensee acknowledges that the IDentify Application is intended to be used by Licensee only as a tool to support review of digital evidence in connection with its investigations, and the IDentify Application and the results generated therefrom should not be considered or relied upon as a substitute for Licensee's customary investigative procedures, protocols and/or requirements.
4. Authority. The person executing this Agreement on behalf of each party represents and warrants that he or she has full authority to execute the same on behalf of such party, and that no other actions or approvals are required for such party to enter into this Agreement and perform its obligations hereunder.

Table with section: ACCEPTED AND AGREED BY: (Veritone, Inc. and Licensee) with fields for Signature, Name, Title, and Date.

ATTACHMENT A

**VERITONE, INC. MASTER LICENSE TERMS AND CONDITIONS
(PS-Rev 20180907)**

(Attached)

VERITONE, INC.

MASTER LICENSE TERMS AND CONDITIONS

These Master License Terms and Conditions (“Terms and Conditions”) apply to any License Agreement (as defined below) between Veritone, Inc. (or one of its subsidiaries) (“Veritone”) and a licensee (“Licensee”).

- 1. License Agreement; Controlling Terms.** For purposes hereof, “License Agreement” shall mean the written license agreement, or the order form, subscription form, statement of work or other document, including any addenda or exhibits thereto, accepted by Veritone in writing, that evidences the purchase of a license from Veritone by the Licensee (either directly or through an authorized reseller of Veritone) to access and use the Veritone aiWARE Platform (the “Platform”) and associated Services (as defined below). The Platform is an artificial intelligence operating system that delivers near real-time media processing and analytics, enabling users to process, index, organize, manage, search, analyze and share audio, video and other data through a suite of applications and other services (collectively, the “Services”). The specific Services, content, fees and payment terms, number of authorized users, and the term of license shall be as set forth in the License Agreement. The License Agreement may also contain other license-specific terms and conditions. The License Agreement and these Terms and Conditions are collectively referred to herein as this “Agreement.” In the event of any conflict or inconsistency among the terms and conditions set forth in the License Agreement and in these Terms and Conditions, the rights and obligations of the parties shall be interpreted based on the following order of priority: (1) the License Agreement and (2) these Terms and Conditions. This Agreement constitutes the complete and exclusive agreement between the parties with respect to the Platform and Services, superseding and replacing any and all prior agreements, communications, and understandings, both written and oral, regarding such subject matter, and no additional or different provision contained in any purchase order form, order acknowledgment form, invoice or similar form of either party will be effective.
- 2. License, Reservation of Rights, Restrictions.**
 - 2.1. License.** Veritone hereby grants to Licensee, during the Term (as defined in Section 7 below), a non-transferable, non-sublicensable, non-exclusive, revocable license to access and use the Platform and Services, subject to the terms and conditions set forth in this Agreement (the “License”). Licensee agrees to use the Platform and Services only for its internal business purposes in accordance with the terms of this Agreement. For the avoidance of doubt, the Platform and Services and its content may not be displayed publicly; provided that, subject to the provisions of Section 2.4 (Restrictions) and Section 11 (Indemnification) of this Agreement, Licensee may post, publish or otherwise share its owned or licensed content via the Platform for which sharing capabilities are enabled during the Term in accordance with the terms of this Agreement.
 - 2.2. Reservation of Rights.** The Platform and Services are licensed by Veritone to Licensee, and not sold. Licensee acquires only the right to use the Platform and Services in accordance with this Agreement and does not acquire any rights of ownership. Nothing herein shall be construed to transfer any rights, title or ownership of any Veritone or Veritone-licensed software, technology, materials, information or Intellectual Property Rights to Licensee. All right, title and interest (including all Intellectual Property Rights) in and to the Platform and Services shall at all times remain the sole and exclusive property of Veritone and/or its respective licensors and all use thereof shall inure to the benefit of Veritone and/or its respective licensors. Except as expressly set forth in this Agreement, no right or license, express or implied, is granted to Licensee or any third party by estoppel, implication, exhaustion or other doctrine of law, equity or otherwise with respect to any product, service, software, technology, materials, information or Intellectual Property Rights of Veritone or its affiliates or licensors. “**Intellectual Property Rights**” means all forms of proprietary rights, titles, interests, and ownership including patents, patent rights, copyrights, trademarks, trade dresses, trade secrets, know-how, mask works, *droit moral* (moral rights), publicity rights and all similar rights of every type that may exist now or in the future in any jurisdiction, including without limitation all applications and registrations therefore and rights to apply for any of the foregoing.
 - 2.3. Third Party Licenses.** Certain software components of the Platform and Services are supplied pursuant to license agreements from third parties, and Licensee agrees that Licensee’s use of the Platform and Services shall be subject to the provisions of such third party license agreements.
 - 2.4. Restrictions.**
 - 2.4.1. License Restrictions.** Licensee agrees to use the Platform and Services only for lawful purposes and only as expressly authorized under this Agreement. Without limiting the generality of the foregoing, except as expressly authorized hereunder, Licensee agrees that it shall not, directly or indirectly: (i) license, sublicense, sell, resell, rent, lease, transfer, assign, distribute, display or otherwise make the Platform or Services, in whole or in part, including any content or data derived therefrom that is not directly owned by Licensee or for which Licensee has

all necessary rights, available to any third party, or use the Platform or Services to provide services to any third party; (ii) reverse engineer, decompile, disassemble, modify, translate, reconstruct, omit, distort, obscure, copy or create derivative works of all or any portion of the Platform, Services, any underlying software, or any other Veritone Property (as defined below), or otherwise attempt to access the source code of the Platform or Services; (iii) incorporate any portion of the Platform or Services into Licensee's own programs or compile any portion of them in combination with Licensee's own programs; (iv) store or otherwise capture to physical media, or enable a third party to store or capture, the Platform or Services or any portion thereof; (v) permit any persons, other than Licensee's authorized users for which Licensee has procured User IDs pursuant to the License Agreement, to access and use the Platform or Services; (vi) upload or transmit through the Platform or Services any material, content, media or data (collectively, "Licensee Content") with respect to which Licensee does not either own all right, title and interest or have the appropriate license(s) for lawful use, or otherwise violate or infringe upon the intellectual property rights of any third party in Licensee's use of the Platform or Services, including the use or distribution of any data derived from the Platform or Services; or (vii) violate any laws, rules or regulations in connection with its use of the Platform or Services, including any data or content contained in, transmitted through or derived therefrom.

2.4.2. Prohibited Acts. Licensee acknowledges and agrees that Licensee is prohibited from doing any act that may have the effect of undermining the integrity of the Platform, Services, any related computer systems, infrastructure or environment, or the methods by which Veritone provides Services to users. Without limiting the generality of the foregoing, Licensee agrees that it shall not, directly or indirectly: (i) defeat, circumvent or modify any authentication technology or other security measures, controls, limitations, or content or functionality filters contained in or associated with the Platform or Services, or otherwise attempt to access any aspect of the Platform or Services that Licensee has not been granted authorization to access under the License Agreement; (ii) deploy or facilitate the use or deployment of any script, routine, robot, spider, scraper or any other automated means, method or device with respect to Licensee's access and use of the Platform and Services for any purpose, including to access, view, select, or copy in whole or in part, any content, program, functionality of the Platform or Services, or any other proprietary information or trade secret of Veritone that is made available through the Platform or Services; (iii) deploy or facilitate the use or deployment of any program, system, means, method or device, for any purpose that places an unreasonable, unnecessary or excessive demand or load on the Platform, Services, or related hardware and connections, or prohibits, denies or delays access to Services by other users or otherwise threatens the continuous services of Veritone's ISPs, suppliers and vendors; (iv) introduce into the Platform or Services any program, executable file or routine (such as a worm, Trojan horse, cancel-bot, time bomb or virus) irrespective of whether any such program or routine results in detrimental harm to the Platform, Services, or any underlying systems or programs; (v) remove any proprietary notices, labels or marks from the Platform or Services; (vi) establish any direct or deep link or other connection to any specific page or location within the Platform or Services, other than the Platform log-in page; (vii) use or attempt to use another user's account without authorization, or interfere with another user's access to the Platform or Services; or (viii) access or use the Platform or Services to design, develop, build, market or support a competitive product or service.

3. Access and Use. Veritone will enable Licensee to access and use the Platform for the duration of the Term, subject to any early termination of this Agreement in accordance with the terms hereof. Access to the Platform will be through unique log-in credentials assigned to Licensee by Veritone (each, a "User ID"). Licensee shall be given that number of User IDs as specified in the License Agreement. Licensee will provide accurate and complete information in registering its authorized users for account access. Licensee acknowledges and agrees that the log-in credentials assigned hereunder are Confidential Information and may only be used by Licensee and its authorized users to access the Platform in accordance with the terms of this Agreement, and that Licensee will not publish, share, or otherwise enable any third party, directly or indirectly, to access the Platform for any purpose. Licensee further agrees that Licensee is responsible for its and its authorized users' use of the Platform, including use via the User IDs, and for any consequences thereof. Licensee agrees to immediately notify Veritone of any unauthorized or improper use of any log-in credentials of Licensee. All of the rights, obligations, restrictions, representations and warranties related to Licensee's access and use of the Platform under this Agreement shall apply to Licensee and all of Licensee's employees, contractors, consultants, representatives and agents (collectively, "Representatives"). Licensee shall be responsible for all acts and omissions of its Representatives in the performance of this Agreement and for any breach of this Agreement by any of its Representatives.

4. Intellectual Property.

4.1. Veritone Property. As between Veritone and Licensee, Veritone and/or its respective licensors retain all right, title and interest (including Intellectual Property Rights) in and to the Platform and Services, including, but not limited to any

elements, components, content, technology, software, code, documentation, derivative works, revisions, enhancements, modifications, condensations and/or compilations of or relating to the Platform and Services, and any trademarks, brand identifiers, materials and information, which are created, authored, developed, conceived and/or reduced to practice by Veritone and/or its respective licensors, including in connection with Veritone's provision of the Platform and Services to Licensee under this Agreement ("**Veritone Property**").

4.2. Licensee Property. As between Licensee and Veritone, Licensee retains all right, title and interest (including Intellectual Property Rights) in and to the Licensee Content, and any software, technology, trademarks, brand identifiers, materials and information which are independently created, authored, developed, conceived or reduced to practice by Licensee.

5. Licensee Content.

5.1. Content Ownership. Licensee represents and warrants that (i) Licensee and/or its licensors own all right, title and interest in and to all Licensee Content uploaded to or transmitted through the Platform or Services, or otherwise have all rights in such Licensee Content as necessary to use the same in connection with Licensee's use of the Platform and Services, (ii) such Licensee Content does not and will not misappropriate or infringe upon any third party's Intellectual Property Rights, or violate any other rights of any third party, and (iii) Licensee has all rights in such Licensee Content necessary to grant the rights contemplated by this Agreement.

5.2. License to Content. Unless otherwise specified in the License Agreement, Licensee hereby grants to Veritone a non-exclusive, royalty-free, worldwide license (i) to use and display all Licensee Content that Licensee provides to Veritone or that are otherwise uploaded to or captured by the Platform through Licensee's use of the Platform and Services to provide the Services and perform its obligations under this Agreement, directly or through its third party service providers, and (ii) to share such Licensee Content with Veritone's third party service providers solely as required for Veritone's provision of the Platform and Services to Licensee.

5.3. Data Security and Destruction. Veritone will maintain and use adequate administrative, physical, and technical safeguards for protection of the security, confidentiality and integrity of all Licensee Content uploaded to or transmitted through the Platform or Services. Licensee Content shall be used and stored by Veritone solely to the extent required to provide the Services and perform its obligations under this Agreement or as otherwise expressly provided in the License Agreement, and Veritone shall not use or store the Licensee Content for any other purpose whatsoever. Upon termination of this Agreement or upon the written request of Licensee at any time, Veritone shall ensure the secure deletion and destruction of all Licensee Content.

6. Feedback. During the Term, Licensee may provide Veritone with such written evaluations, comments and/or suggestions (collectively, "**Feedback**") regarding the Platform or Services. Licensee acknowledges and agrees that any Feedback provided to Veritone by Licensee hereunder shall be deemed to be Veritone Property and Licensee hereby assigns all right, title and interest in and to such Feedback to Veritone and acknowledges that Veritone will be entitled to, without limitation, implement and exploit any such Feedback in any manner without any restriction or obligation. Notwithstanding the foregoing, Licensee acknowledges that Veritone is not obligated to act on any such Feedback.

7. Term and Termination.

7.1. Term. The term of this Agreement and the License shall be as set forth in the License Agreement (the "**Term**").

7.2. Termination. In addition to any termination rights expressly provided in the License Agreement, this Agreement may be terminated by either party if the other party (i) materially breaches any provision of this Agreement which remains uncured for a period of fourteen (14) days from the date of written notice of such breach; or (ii) makes an assignment for the benefit of its creditors, is declared insolvent, or has a receiver or trustee in bankruptcy appointed to take charge of all or part of such party's property.

7.3. Effect of Termination. If at any time this Agreement is terminated, or upon expiration of the Term, the License and all other rights granted to Licensee herein shall automatically terminate and Licensee shall immediately cease using the Platform and Services.

7.4. Survival. The provisions of Sections 2.2 (Reservation of Rights), 4 (Intellectual Property), 6 (Feedback), 7.3 (Effect of Termination), 8.1 (Fees and Payments), 8.2 (Taxes), 10 (Confidentiality), 11 (Indemnification), 12.2 and 12.3 (Warranty and Disclaimers), 13 (Limitation of Liability), 14 (Miscellaneous) hereof and the payment terms of License Agreement, as applicable, shall survive the expiration or any early termination of this Agreement for any reason.

8. Fees, Charges and Payments.

8.1. Fees and Payments. In consideration for the License and Licensee's access and use of the Platform and Services, Licensee shall pay the license fees, and any applicable additional fees, as set forth in the License Agreement (collectively, the "Fees"). All Fees and other amounts due under this Agreement are payable in U.S. dollars.

8.2. Taxes. All Fees and any other amounts due hereunder are exclusive of taxes and similar assessments which may be imposed on the delivery of the Platform and Services and any other transactions contemplated hereby. Licensee shall be solely responsible for the payment of any and all sales, use, value added, excise, import, or other similar taxes or payments in lieu thereof, including interest and penalties thereon, imposed by any authority, government or governmental agency arising out of or in connection with amounts due hereunder (other than those levied on Veritone's income), and Licensee shall make such payments, and timely file any return or information required by treaty, law, rule or regulation. Upon request, Licensee shall provide Veritone with documentation evidencing such payments. If Veritone is required to pay any such taxes, duties or fees, Licensee shall reimburse Veritone immediately upon receipt of Veritone's invoice thereof.

8.3. Suspension of Platform Access. In addition to Veritone's termination rights set forth herein and without prejudice to any other rights of Veritone at law or in equity, Veritone may suspend its performance under this Agreement and any other agreement with Licensee and Licensee's access to the Platform if Licensee fails to comply with any part of its payment obligations set forth herein. Such suspension of service shall not suspend or otherwise affect Licensee's payment obligations set forth herein.

9. Changes to Platform, Service and Fees. Veritone may, from time to time, in its sole discretion, make changes to the Platform and Services, or a portion thereof including, without limitation, formats, content, reports, functionality, and/or techniques ("Service Change"). In the event of a Service Change, Veritone may, adjust the Fees for the Platform and Services ("Fee Change") in writing. Such Fee Change shall become effective on the date stated in Veritone's notice to Licensee unless, within fifteen (15) days after a Fee Change notice that would result in an increase in the Fees, Licensee notifies Veritone in writing of its refusal to accept the Fee Change, in which event the applicable License to Licensee shall terminate as of the effective date of the change; provided, however, that if the Fee Change is an increase in the Fees, Veritone may, in its sole discretion, elect to rescind the Fee Change, in which case the Platform and Services, as changed, shall continue as provided herein.

10. Confidentiality.

10.1. Confidential Information. Each party (a receiving party) acknowledges and agrees that during the Term and in the course of using the Platform and Services and performing its duties under this Agreement, it may obtain information relating to the other party (a disclosing party), its and/or its customers', vendors', or third party service providers' business or technologies, which is of a confidential and proprietary nature ("**Confidential Information**"). Such Confidential Information may include, but is not limited to, trade secrets, know-how, inventions, techniques, processes, software, algorithms, programs, schematics, data, technology roadmap, sales and marketing plans, and any other information which the receiving party knows or has reason to know is, or which by its nature would reasonably be considered to be, confidential, proprietary or trade secret information of the other party. Without limiting the foregoing, Confidential Information of Veritone shall include the Platform, Services and all associated software and documentation, as well as Feedback or any results of the evaluation or testing of the Platform or Services. The receiving party shall at all times, both during the Term and for a period of three (3) years after its termination (or, in the case of the Platform, Services and any associated software or trade secrets, in perpetuity), keep in trust and confidence all Confidential Information of the disclosing party, and shall not (i) use such Confidential Information other than as expressly authorized under this Agreement or as required for the receiving party to perform its obligations under this Agreement, or (ii) disclose any Confidential Information of the disclosing party to third parties (other than to Veritone's third party service providers in connection with the performance of its obligations under this Agreement), without the disclosing party's prior written consent. The receiving party further agrees to immediately return to the disclosing party or destroy all Confidential Information (including all copies, extracts and summaries thereof) in the receiving party's possession, custody, or control upon the expiration or any termination of this Agreement. The obligations of confidentiality shall not apply to information which (a) has entered the public domain except where such entry is the result of the receiving party's breach of this Agreement; (b) prior to disclosure hereunder, was already in the receiving party's possession and not subject to any confidentiality obligations, as demonstrated by written evidence; (c) subsequent to disclosure hereunder is obtained by the receiving party on a non-confidential basis from a third party who has the right to disclose such information to the receiving party; or (d) has been independently developed by the receiving party without use of or reference to the disclosing party's Confidential Information, as demonstrated by written evidence.

10.2. Permitted Disclosures. The receiving party may make disclosures (i) as required by applicable law or the rules of an stock exchange on which such party's shares are then traded; or (ii) as compelled by court order issued by a court of competent

jurisdiction provided that the receiving party subject to such court order (a) provides the disclosing party with prompt written notice of any such compelled disclosure, (b) uses diligent reasonable efforts to limit disclosure, (c) uses commercially reasonable efforts to obtain confidential treatment or a protective order in connection with the information subject to such compelled disclosure, and (d) allows the disclosing party to participate in any such proceeding.

11. Indemnification.

11.1. Licensee Indemnification of Veritone. Licensee will defend, indemnify and hold harmless Veritone and its subsidiaries, affiliates, successors, assigns, licensors, and their respective members, officers, directors, employees, licensors, agents, from and against any liability or expense, including, without limitation, any expenses, losses, damages, judgments, litigation costs and reasonable attorneys' fees, that Veritone may incur as a result of any claim, suit or proceeding brought against Veritone by any third party arising or resulting from (a) Licensee's breach of any representation, warranty, covenant or obligation contained in this Agreement; or (b) Licensee's use of the Platform or Services (including uploading, using, publishing, posting or otherwise sharing of Licensee's Content or any other data or content derived from the Platform or Services) in any manner that violates this Agreement or any laws, rules, regulations or third party terms and conditions, or that misappropriates or infringes the rights (including Intellectual Property Rights) of any third party; *provided that* Veritone gives Licensee prompt notice of any such claims, cooperates with Licensee in responding to such claims, and permits Licensee to control the defense or settlement of such claims, subject to Veritone's right to (i) conduct the defense of such claims at Veritone's expense, or participate in the defense of such claims with its own counsel at its own expense, and (ii) approve any settlement that binds or purports to bind Veritone.

11.2. Veritone Indemnification of Licensee. Veritone will defend, indemnify and hold harmless Licensee and its subsidiaries, affiliates, successors, assigns, licensors, and their respective members, officers, directors, employees, licensors, agents, from and against any liability or expense, including without limitation, any expenses, losses, damages, judgments, litigation costs and reasonable attorneys' fees that Licensee may incur as a result of any claim, suit or proceeding brought against Licensee by any third party arising or resulting from (a) Veritone's breach of any representation, warranty, covenant or obligation contained in this Agreement; or (b) any allegation that the Platform or Services, or any part thereof, misappropriates or infringes upon any third party's Intellectual Property Rights, except to the extent such claims arise from Licensee's negligence, misconduct or violation of any terms of this Agreement; *provided that* Licensee gives Veritone prompt notice of any such claims, cooperates with Veritone in responding to such claims, and permits Veritone to control the defense or settlement of such claims, subject to Licensee's right to (i) conduct the defense of such claims at Licensee's expense, or participate in the defense of such claims with its own counsel at its own expense, and (ii) approve any settlement that binds or purports to bind Licensee. If the Platform, in whole in part, becomes or, in Veritone's opinion is likely to become, the subject of an infringement claim or action, Veritone may, at its option: (x) procure, at no cost to Licensee, the right for Licensee to continue using the Platform; (y) replace or modify the Platform to render the Platform non-infringing, provided there is no material loss of functionality; or (z) if, in Veritone's reasonable opinion, neither (x) nor (y) above is commercially feasible, terminate this Agreement and refund any prepaid amounts for unused Services during the terminated portion of the Term. The foregoing states Veritone's sole obligation and Licensee's exclusive remedy in the event any such infringement claim or action is commenced or is likely to be commenced.

12. Warranties and Disclaimers.

12.1. Mutual Warranties. Each party represents and warrants to the other that: (i) it is duly organized and validly existing under the laws of the jurisdiction of its incorporation or formation, and has full power, rights and authority to enter into this Agreement and carry out its obligations hereunder; (ii) the person executing this Agreement is authorized to do so on its behalf; (iii) this Agreement is valid and legally binding upon it and (iv) the execution, delivery and performance thereof by such party does not conflict with any other agreement, instrument or understanding to which it is a party or by which it may be bound, nor would violate any applicable law or regulation.

12.2. Disclaimer. THE PLATFORM, SERVICES AND ANY OTHER VERITONE PRODUCTS AND SERVICES ARE PROVIDED ON AN "AS IS" AND "AS AVAILABLE" BASIS. EXCEPT AS EXPRESSLY PROVIDED IN THIS AGREEMENT, VERITONE MAKES NO WARRANTY, EXPRESS OR IMPLIED, WITH RESPECT TO THE PLATFORM AND SERVICES, INCLUDING, WITHOUT LIMITATION, ANY WARRANTY AS TO THE ACCURACY OF PROCESSING RESULTS, ANY WARRANTY OF MERCHANTABILITY, QUALITY OR FITNESS FOR A PARTICULAR PURPOSE, WARRANTIES ARISING FROM COURSE OF DEALING OR USAGE OF TRADE, AND WARRANTIES OF NON-INFRINGEMENT. VERITONE DOES NOT WARRANT THAT THE PLATFORM AND SERVICES ARE ERROR-FREE, WILL RUN UNINTERRUPTED, OR THAT ALL ERRORS CAN OR WILL BE CORRECTED. NO ADVICE OR INFORMATION, WHETHER ORAL OR WRITTEN, OBTAINED BY LICENSEE FROM VERITONE SHALL CREATE ANY SUCH WARRANTY.

12.3. LICENSEE ACKNOWLEDGES AND AGREES THAT THE INTERNET IS A PUBLIC NETWORK OVER WHICH VERITONE EXERTS NO CONTROL. VERITONE MAKES NO REPRESENTATIONS OR WARRANTIES WHATSOEVER, AND SHALL HAVE NO LIABILITY WHATSOEVER, WITH RESPECT TO THE ACCURACY, DEPENDABILITY, PRIVACY, SECURITY, AUTHENTICITY OR COMPLETENESS OF DATA TRANSMITTED OVER OR OBTAINED USING THE INTERNET OUTSIDE OF THOSE SYSTEMS AND NETWORKS CONTROLLED BY VERITONE, OR ANY INTRUSION, VIRUS, DISRUPTION, LOSS OF COMMUNICATION, LOSS OR CORRUPTION OF DATA, OR OTHER ERROR OR EVENT CAUSED OR PERMITTED BY OR INTRODUCED THROUGH LICENSEE'S OWN USE OF THE INTERNET. LICENSEE IS SOLELY RESPONSIBLE FOR IMPLEMENTING ADEQUATE FIREWALL, PASSWORD AND OTHER SECURITY MEASURES TO PROTECT ITS SYSTEMS, DATA AND APPLICATIONS FROM UNWANTED INTRUSION, WHETHER OVER THE INTERNET OR BY OTHER MEANS.

13. Limitation of Liability.

13.1. EXCEPT FOR (A) BREACHES OF EACH PARTY'S OBLIGATIONS UNDER SECTION 10 (CONFIDENTIALITY), AND (B) AMOUNTS FINALLY AWARDED OR SETTLED IN A THIRD PARTY CLAIM FOR WHICH A PARTY IS RESPONSIBLE UNDER SECTION 11 (INDEMNIFICATION), NEITHER PARTY, INCLUDING ITS OFFICERS, DIRECTORS, EMPLOYEES, REPRESENTATIVES AND AFFILIATES, SHALL BE LIABLE FOR ANY INDIRECT, INCIDENTAL, SPECIAL, CONSEQUENTIAL, OR PUNITIVE DAMAGES, INCLUDING WITHOUT LIMITATION, LOST DATA OR LOST PROFITS, OR COSTS OF PROCURING SUBSTITUTE GOODS OR SERVICES, HOWEVER ARISING, EVEN IF IT HAS BEEN ADVISED OF THE POSSIBILITY OF SUCH DAMAGES.

13.2. EXCEPT WITH RESPECT TO EACH PARTY'S CONFIDENTIALITY AND INDEMNIFICATION OBLIGATIONS HEREUNDER, NEITHER PARTY'S LIABILITY FOR DAMAGES ARISING OUT OF, RELATING TO OR IN ANY WAY CONNECTED WITH THIS AGREEMENT SHALL EXCEED THE TOTAL FEES PAID BY LICENSEE TO VERITONE UNDER THIS AGREEMENT.

14. MISCELLANEOUS

14.1. No Assignment. Neither party may assign any of its rights or obligations under this Agreement without the prior written consent of the other party, except that either party may assign its rights and obligations under this Agreement without the consent of the other party to an affiliate directly or indirectly controlling, controlled by, or under direct or indirect common control with such party or in connection with any merger (by operation of law or otherwise), consolidation, reorganization, change in control or sale of all or substantially all of its assets related to this Agreement or similar transaction. This Agreement inures to the benefit of and shall be binding on the parties' permitted assignees, transferees and successors.

14.2. Severability. If any provision of this Agreement is found by a court of competent jurisdiction to be invalid, the parties nevertheless agree that the court should endeavor to give effect to the parties' intentions as reflected in such provision, and the other provisions of this Agreement remain in full force and effect.

14.3. No Waiver. The failure of either party to exercise or enforce any right or provision of this Agreement shall not constitute a waiver of such right or provision.

14.4. Controlling Law. This Agreement shall be governed by and construed in accordance with the laws of the State of California (other than the conflict of law rules) and subject to the sole jurisdiction of the courts sitting in Orange County, California. Notwithstanding the foregoing, nothing in this Section 14.4 shall be deemed to limit the parties' rights to seek injunctive relief in any other court of law of competent jurisdiction.

14.5. Independent Contractors. This Agreement does not create any relationship other than Veritone as an independent contractor performing services covered by this Agreement and Licensee as the party contracting with Veritone for those services. No party is a partner or a legal representative of the other for any purpose whatsoever, nor is any party authorized to make any contract, agreement or warranty on behalf of any other party. Under no circumstance shall one party's employees be construed to be employees of the other party.

14.6. Publicity. Except as required or compelled by applicable law, the rules of any stock exchange, or a court order issued by a court of competent jurisdiction, neither party will make any public statement regarding, or disclose, advertise or publish the terms and conditions of this Agreement without the prior written consent of the other party; provided, however, that Veritone may reference Licensee on Veritone's website, other marketing materials, investor relations materials, and as a customer in Veritone's SEC filings.

14.7. Notices. All notices to either party shall be in writing and delivered by hand or by certified mail or overnight delivery service to the address set forth by Licensee and/or Veritone in the License Agreement, or to such other address as either party shall provide by notice to the other party. Alternatively, the parties may, at their election, utilize email as the method of delivery of any such notice to be provided hereunder. Any such notices sent by email shall be delivered to the email addresses set forth in the License Agreement, or such other email address as designed by a party during the Term. Notices shall be deemed effective when delivered to the applicable address, unless any such notice is sent by

email, in which event, notice shall be deemed effective upon confirmation of delivery by a “read receipt” or other such notice generated by the applicable email system, but in any event, by reply of the recipient of such notice.

- 14.8. Electronic Communication.** In connection with its use of the Platform and Services, Licensee consents to receiving communications from Veritone electronically. Veritone will communicate with Licensee by e-mail or by posting notices on the Platform or through any Services. Licensee agrees that all notices, disclosures and other communications that Veritone provides to Licensee electronically satisfy any legal requirement that such communications be in writing.
- 14.9. Force Majeure.** Except for the obligation to make payments of any Fees or any other amounts due hereunder, neither party will be liable for any failure or delay in its performance under the Agreement due to any cause beyond such party’s control including acts of war, terrorism, acts of God, embargo, riot, sabotage, labor shortage or dispute, governmental act, or failure of the Internet, or any component comprising or operating the network infrastructure thereof (each, a “**Force Majeure Event**”), provided that the delayed party: (i) gives the other party prompt notice of such cause, and (ii) uses its reasonable commercial efforts to promptly correct such failure or delay in performance. If Veritone is unable to provide Service(s) for a period of sixty (60) consecutive days as a result of a continuing Force Majeure Event, either party may elect to terminate this Agreement.
- 14.10. Construction.** This Agreement shall be fairly interpreted and construed in accordance with its terms and without strict interpretation or construction in favor of or against either party. Each party has had the opportunity to consult with counsel in the negotiation of this Agreement.
- 14.11. Counterparts.** This Agreement may be executed in one or more counterparts (including fax or email) each of which shall be deemed an original but all of which taken together shall be deemed one and the same instrument.
- 14.12. Headings.** Unless otherwise expressly stated in this Agreement, the words “herein,” “hereof,” “hereto,” and “hereunder” and other words of similar import refer to this Agreement as a whole and not to any particular section, subsection, or other subdivision. The words “include” and “including” shall not be construed or interpreted as terms of limitation. The words “day,” “month,” and “year” mean, respectively, calendar day, calendar month, and calendar year. Section headings are for reference purposes only, and should not be used in the interpretation hereof.
- 14.13. Amendment.** No addendum, waiver, consent, modification, amendment or change of the terms of this Agreement shall bind either party unless in a writing that references this Agreement and is signed by duly authorized representatives of Licensee and Veritone.
- 14.14. Attorney’s Fees.** If any action arises under this Agreement, including, without limitation the interpretation or enforcement of any term of this Agreement, the prevailing party in any such action shall be entitled to recover its reasonable attorney’s fees and related costs.

From: Mark Anderson
Sent: Tuesday, February 19, 2019 7:25 AM PST
To: Noelle Smiley
Subject: FW: Veritone pilot agreement
Attachments: Irvine PD Data Sharing Addendum (20190214).docx,
Irvine Police Department Trial License Agreement (IDentify) (20190214).docx,
Master License Terms and Conditions (PS Rev 20180907).pdf, image001.png, image002.png

Commander,

Attached is the revised contract with Veritone reference the trial period T&E for the facial recognition software. Would you like me to send it to the City Attorney's Office for review?

Thanks

Mark

From: William Hillyard
Sent: Friday, February 15, 2019 1:48 PM
To: Mark Anderson <manderson@cityofirvine.org>
Subject: FW: Veritone pilot agreement

LT,

Here is the revised License Agreement for your review. As we discussed, they have changed the wording, and in fact changed the title of the document all together. The document is now a "Pilot Evaluation License Agreement" with an end date of May 30, 2019. The license fee is "Waived for pilot evaluation" and there is no mention anywhere in any of the new documentation of a cost for an ongoing license for the software if we decided to move forward with making a purchase. As we've talked about, not having any idea of a pricing structure is not ideal, but I don't believe even at this point that Veritone themselves have any clue what to charge for an annual license for this software. The agreement we would be signing here is the same agreement Station 18 and Anaheim PD are operating under.

Please let me know if you have any question regarding the new documents.

Thank you,



William Hillyard | Detective | Irvine Police Department
949-724-7085 | 1 Civic Center Plaza, Irvine, CA 92606
whillyard@cityofirvine.org | cityofirvine.org

From: Tom Avery <tavery@veritone.com>
Sent: Friday, February 15, 2019 6:17 AM

To: William Hillyard <whillyard@cityofirvine.org>

Subject: Re: Veritone pilot agreement

Bill,

The updated pilot agreement is attached for your departments review. Let me know if you have any questions and have a good weekend.

Tom

From: William Hillyard <whillyard@cityofirvine.org>

Date: Thursday, February 14, 2019 at 12:27 PM

To: Tom Avery <tavery@veritone.com>

Subject: Re: Veritone pilot agreement

Hi Tom. Just checking in on the status of the revised quote?

Hope you're having a good/dry day.

Sent from my iPhone

On Feb 5, 2019, at 2:37 PM, Tom Avery <tavery@veritone.com> wrote:

Copy.

On Tue, Feb 5, 2019, 14:36 William Hillyard <whillyard@cityofirvine.org> wrote:

I just tried to call your cell. Measure S

I'll probably be there for at least an hour.

Sent from my iPhone

On Feb 5, 2019, at 2:19 PM, Tom Avery <tavery@veritone.com> wrote:

I'll be in route to the Starbucks in about 10. Driving time from Irvine.

On Tue, Feb 5, 2019, 14:15 William Hillyard <whillyard@cityofirvine.org> wrote:

I'm around today.

Investigation

that doesn't work I'll be in tomorrow at 10am. Feel free to call me at Privacy anytime.

I'd like to try and get an answer to the LT by late today or tomorrow AM because they have the command staff meeting tomorrow where they probably want to present the agreement to the Chief.

Thanks,



William Hillyard | Detective | Irvine Police Department
949-724-7085 | 1 Civic Center Plaza, Irvine, CA 92606
whillyard@cityofirvine.org | cityofirvine.org

From: Tom Avery <tavery@veritone.com>
Sent: Tuesday, February 05, 2019 1:46 PM
To: William Hillyard <whillyard@cityofirvine.org>
Subject: Re: FW: Veritone pilot agreement

This was news to me as well. I stopped by HQ but you must be out on assignment. Let me know when you have some time to talk and I'll drop by.

Tom

On Tue, Feb 5, 2019, 12:52 William Hillyard <whillyard@cityofirvine.org> wrote:

Tom,

Can you please see the question below from Lt. Anderson. In the agreement it states the waived fee is \$15,000 per month, is that meant to be per year for the license fee we discussed in the meeting?

Thank you,



William Hillyard | Detective | Irvine Police Department
949-724-7085 | 1 Civic Center Plaza, Irvine, CA 92606
whillyard@cityofirvine.org | cityofirvine.org

From: Mark Anderson <manderson@cityofirvine.org>
Sent: Monday, February 04, 2019 2:18 PM
To: William Hillyard <whillyard@cityofirvine.org>
Subject: FW: Veritone pilot agreement

Hi Sir. In the License Agreement attached it talked about 15,000 per month, but it's waived? Just not clear what that means. Can you take and look at it and explain or reach out to Veritone and ask for an explanation. Thank you

From: William Hillyard
Sent: Thursday, January 31, 2019 8:13 AM
To: Mark Anderson <manderson@cityofirvine.org>
Subject: FW: Veritone pilot agreement

LT,

Attached are the documents for the Pilot Program agreement with Veritone that need Chief Hamel's signature. Here are some brief points regarding the agreements:

- Irvine PD can opt out of the data sharing portion of the software at any time. If we did opt out but continued to use the software the suspect photos would only be compared to our database of known offenders, and no other agencies would have access to our database of booking photos and known offenders.
- The free trial period for the Pilot Program is 90 days, not 60 as was discussed during our meeting with Veritone.
- The initial License Agreement states that we will have (5) user profiles. This is only for the term of the Pilot Program. If we go forward with purchasing the software we will have an unlimited number of user licenses.
- Section 5.3 of the Master License Terms and Conditions states that if we cancel our relationship with Veritone any data we have provided them is removed from their servers and deleted. There are several portions throughout the agreements which clearly spell out that the data provided by Irvine PD remains the property of Irvine PD and should we terminated our contract with them they have no rights to retain or continue to use any data we provided them.
- The data we are providing other agencies access to through Veritone is no different than the data we upload to Coplink on a daily basis.
- For the Pilot Program we will provide Veritone with an initial data dump of our current database of booking photos, if we go forward with purchasing the software Veritone can set up and automated upload of new booking photos so there is no additional workload for our personnel.

I spoke with Nick Rycroft Monday reference the IT portion of it and he stated when the agreement is signed by the Chief he would begin working on the data export as requested by Veritone.

Please let me know if can provide any additional information.

Thank you,

Bill Hillyard

Begin forwarded message:

From: Tom Avery <tavery@veritone.com>
Date: January 30, 2019 at 7:15:09 AM PST
To: William Hillyard <whillyard@cityofirvine.org>
Subject: Veritone pilot agreement

Bill,

Attached is the Veritone pilot agreement documents which also include the terms and conditions as well as the data sharing agreement. Let me know if you have any questions.

Thanks,
Tom

Tom Avery
Vice President Public Safety
Veritone Government
tavery@veritone.com
Privacy cell

**Veritone IDentify Application
Data Sharing Addendum**

This Data Sharing Addendum (“Addendum”) is entered into as of February __, 2019, by and between Veritone, Inc. (“Veritone”) and Irvine Police Department (“Licensee”). This Addendum is incorporated by reference into, made a part of and governed by the terms of the Pilot Evaluation License Agreement dated February __, 2019 between Veritone and Licensee (the “Agreement”). In the event of any conflict or inconsistency between the provisions contained in the Agreement and the provisions contained in this Addendum with respect to the subject matter hereof, the provisions of this Addendum shall govern and control. Capitalized terms used but not defined herein shall have the meanings ascribed to them in the Agreement.

1. **IDentify Application.** Veritone has granted to Licensee a right and license to access and use the IDentify Application within the Platform. The IDentify Application allows users to upload booking, arrest and known offender databases (collectively, “Booking Databases”) and use facial recognition technology to compare digital evidence from crime scenes with the Booking Databases to identify potential suspects. The IDentify Application also allows Licensee and other judicial and law enforcement agencies (each, an “Agency”) to elect to share access to their Booking Databases as further described in this Addendum (the “Data Sharing Option”).
2. **Participation in Data Sharing Option.** By executing this Addendum, Licensee hereby elects to participate in the Data Sharing Option, and each of Licensee and Veritone acknowledges and agrees to the supplemental terms and conditions applicable to the Data Sharing Option as set forth in this Addendum, in addition to the terms of the Agreement. All rights granted by each party under this Addendum shall continue during the Term of the Agreement, unless earlier terminated as set forth herein.
3. **Databases.**
 - (a) **Shared Databases.** Licensee will participate in the Data Sharing Option with respect to the Booking Databases indicated below (the option indicated below referred to hereinafter as the “Shared Databases”) (*check/complete one option*):
 - The Booking Databases maintained in the Platform by all other Agencies participating in the Data Sharing Option; or
 - The Booking Databases maintained in the Platform by the following Agencies:
 1. N/A
 - 2.
 - 3.
 - 4.
 - (b) **Access to Licensee Databases.** Licensee hereby grants to Veritone the right to grant access to all Booking Databases that Licensee maintains in the Platform (the “Licensee Databases”) to each other Agency that is participating in the Data Sharing Option and is maintaining a Shared Database in the Platform for use by each such Agency in connection with its use of the IDentify Application, and to other Agencies under limited trial licenses for evaluation purposes.
 - (c) **Access to Shared Databases.** Veritone will make available through the IDentify Application, and hereby grants to Licensee the right to access and use, the Shared Databases.
4. **Termination of Participation.** Licensee may terminate its participation in the Data Sharing Option by providing at least 60 days prior written notice to Veritone (or such shorter period as may be required by a court having jurisdiction). In such event, (i) Veritone will restrict access to the Licensee Databases to Licensee only and will terminate access to the Licensee Databases by any other Agency, and (ii) Veritone will terminate Licensee’s access to all Shared Databases, and Licensee’s use of the IDentify Application thereafter will be limited to use with the Licensee Databases only. Licensee acknowledges that Licensee’s right to access and use the Shared Databases is subject at all times to the participation by other Agencies in the Data Sharing Option on a continuous basis. If any Agency terminates its participation in the Data Sharing Option, Licensee will no longer

have access to the Shared Databases of such Agency or to any information generated from the Shared Databases associated with previously run searches and any resulting matches.

5. **Licensee Responsibilities.** Licensee shall be solely responsible for its use of the Shared Databases. Licensee represents and warrants that (a) it will use the Shared Databases solely in conjunction with its use of the IDentify Application in accordance with the terms of this Addendum, and (b) it will use the Shared Databases (including all data, content, materials, information and results contained in and/or generated from any of the foregoing) in compliance with all applicable laws, statutes, ordinances, rules, regulations, consent decrees, and/or requirements of any regulatory authority. Licensee shall defend, indemnify and hold harmless Veritone and its affiliates and licensors, and their respective members, officers, directors, employees, and agents, from and against any liability, losses, damages, judgments, costs and expenses, including litigation costs and reasonable attorneys' fees, arising out of or resulting from Licensee's use of the Shared Databases or Licensee's breach of any of its representations, warranties or obligations set forth in this Addendum.
6. **Authority.** The person executing this Addendum on behalf of each party represents and warrants that he or she has full authority to execute the same on behalf of such party, and that no other actions or approvals are required for such party to enter into this Addendum and perform its obligations hereunder.

IN WITNESS WHEREOF, the parties have caused this Addendum to be executed by their duly authorized representatives as of the date first above written.

VERITONE, INC.

IRVINE POLICE DEPARTMENT

Signature:

Signature:

Name:

Name:

Title:

Title:



PILOT EVALUATION LICENSE AGREEMENT

This Pilot Evaluation License Agreement ("Agreement") is entered into as of the date of the last signature below ("Effective Date") by and between Veritone, Inc. (for itself and/or its subsidiaries), having a principal office located at 575 Anton Boulevard, Suite 100, Costa Mesa, CA 92626 ("Veritone") and the entity listed under Licensee Information below ("Licensee"), with respect to license(s) to Veritone's aiWARE Platform and related Services.

Table with sections: LICENSEE INFORMATION (Agency Name, Address, Contact Name, Phone, Email), LICENSE AND SERVICES DETAILS (Term, Start Date, End Date, No. of Users, License Fees, Services, Cognitive Processing), and TERMS AND CONDITIONS.

- 1. Master License Terms and Conditions. This Agreement and Licensee's access to and use of the Platform and Services shall be governed by the Veritone Master License Terms and Conditions attached hereto as Attachment A and incorporated herein by reference (the "Terms and Conditions").
2. Identify Application and Cognitive Processing. During the Term, Veritone will provide Licensee with access to the IDentify Application and the cognitive processing specified above for content uploaded to the Platform by Licensee through the IDentify Application, for purposes of evaluation of the Platform and Services by Licensee.
3. Limitations. Licensee acknowledges that the IDentify Application is intended to be used by Licensee only as a tool to support review of digital evidence in connection with its investigations, and the IDentify Application and the results generated therefrom should not be considered or relied upon as a substitute for Licensee's customary investigative procedures, protocols and/or requirements.
4. Authority. The person executing this Agreement on behalf of each party represents and warrants that he or she has full authority to execute the same on behalf of such party, and that no other actions or approvals are required for such party to enter into this Agreement and perform its obligations hereunder.

Table with 2 columns: VERITONE, INC. and LICENSEE. Rows include Signature, Name, Title, and Date for both parties.

ATTACHMENT A

**VERITONE, INC. MASTER LICENSE TERMS AND CONDITIONS
(PS-Rev 20180907)**

(Attached)

VERITONE, INC.

MASTER LICENSE TERMS AND CONDITIONS

These Master License Terms and Conditions (“Terms and Conditions”) apply to any License Agreement (as defined below) between Veritone, Inc. (or one of its subsidiaries) (“Veritone”) and a licensee (“Licensee”).

- 1. License Agreement; Controlling Terms.** For purposes hereof, “License Agreement” shall mean the written license agreement, or the order form, subscription form, statement of work or other document, including any addenda or exhibits thereto, accepted by Veritone in writing, that evidences the purchase of a license from Veritone by the Licensee (either directly or through an authorized reseller of Veritone) to access and use the Veritone aiWARE Platform (the “Platform”) and associated Services (as defined below). The Platform is an artificial intelligence operating system that delivers near real-time media processing and analytics, enabling users to process, index, organize, manage, search, analyze and share audio, video and other data through a suite of applications and other services (collectively, the “Services”). The specific Services, content, fees and payment terms, number of authorized users, and the term of license shall be as set forth in the License Agreement. The License Agreement may also contain other license-specific terms and conditions. The License Agreement and these Terms and Conditions are collectively referred to herein as this “Agreement.” In the event of any conflict or inconsistency among the terms and conditions set forth in the License Agreement and in these Terms and Conditions, the rights and obligations of the parties shall be interpreted based on the following order of priority: (1) the License Agreement and (2) these Terms and Conditions. This Agreement constitutes the complete and exclusive agreement between the parties with respect to the Platform and Services, superseding and replacing any and all prior agreements, communications, and understandings, both written and oral, regarding such subject matter, and no additional or different provision contained in any purchase order form, order acknowledgment form, invoice or similar form of either party will be effective.
- 2. License, Reservation of Rights, Restrictions.**
 - 2.1. License.** Veritone hereby grants to Licensee, during the Term (as defined in Section 7 below), a non-transferable, non-sublicensable, non-exclusive, revocable license to access and use the Platform and Services, subject to the terms and conditions set forth in this Agreement (the “License”). Licensee agrees to use the Platform and Services only for its internal business purposes in accordance with the terms of this Agreement. For the avoidance of doubt, the Platform and Services and its content may not be displayed publicly; provided that, subject to the provisions of Section 2.4 (Restrictions) and Section 11 (Indemnification) of this Agreement, Licensee may post, publish or otherwise share its owned or licensed content via the Platform for which sharing capabilities are enabled during the Term in accordance with the terms of this Agreement.
 - 2.2. Reservation of Rights.** The Platform and Services are licensed by Veritone to Licensee, and not sold. Licensee acquires only the right to use the Platform and Services in accordance with this Agreement and does not acquire any rights of ownership. Nothing herein shall be construed to transfer any rights, title or ownership of any Veritone or Veritone-licensed software, technology, materials, information or Intellectual Property Rights to Licensee. All right, title and interest (including all Intellectual Property Rights) in and to the Platform and Services shall at all times remain the sole and exclusive property of Veritone and/or its respective licensors and all use thereof shall inure to the benefit of Veritone and/or its respective licensors. Except as expressly set forth in this Agreement, no right or license, express or implied, is granted to Licensee or any third party by estoppel, implication, exhaustion or other doctrine of law, equity or otherwise with respect to any product, service, software, technology, materials, information or Intellectual Property Rights of Veritone or its affiliates or licensors. “**Intellectual Property Rights**” means all forms of proprietary rights, titles, interests, and ownership including patents, patent rights, copyrights, trademarks, trade dresses, trade secrets, know-how, mask works, *droit moral* (moral rights), publicity rights and all similar rights of every type that may exist now or in the future in any jurisdiction, including without limitation all applications and registrations therefore and rights to apply for any of the foregoing.
 - 2.3. Third Party Licenses.** Certain software components of the Platform and Services are supplied pursuant to license agreements from third parties, and Licensee agrees that Licensee’s use of the Platform and Services shall be subject to the provisions of such third party license agreements.
 - 2.4. Restrictions.**
 - 2.4.1. License Restrictions.** Licensee agrees to use the Platform and Services only for lawful purposes and only as expressly authorized under this Agreement. Without limiting the generality of the foregoing, except as expressly authorized hereunder, Licensee agrees that it shall not, directly or indirectly: (i) license, sublicense, sell, resell, rent, lease, transfer, assign, distribute, display or otherwise make the Platform or Services, in whole or in part, including any content or data derived therefrom that is not directly owned by Licensee or for which Licensee has

all necessary rights, available to any third party, or use the Platform or Services to provide services to any third party; (ii) reverse engineer, decompile, disassemble, modify, translate, reconstruct, omit, distort, obscure, copy or create derivative works of all or any portion of the Platform, Services, any underlying software, or any other Veritone Property (as defined below), or otherwise attempt to access the source code of the Platform or Services; (iii) incorporate any portion of the Platform or Services into Licensee's own programs or compile any portion of them in combination with Licensee's own programs; (iv) store or otherwise capture to physical media, or enable a third party to store or capture, the Platform or Services or any portion thereof; (v) permit any persons, other than Licensee's authorized users for which Licensee has procured User IDs pursuant to the License Agreement, to access and use the Platform or Services; (vi) upload or transmit through the Platform or Services any material, content, media or data (collectively, "Licensee Content") with respect to which Licensee does not either own all right, title and interest or have the appropriate license(s) for lawful use, or otherwise violate or infringe upon the intellectual property rights of any third party in Licensee's use of the Platform or Services, including the use or distribution of any data derived from the Platform or Services; or (vii) violate any laws, rules or regulations in connection with its use of the Platform or Services, including any data or content contained in, transmitted through or derived therefrom.

2.4.2. Prohibited Acts. Licensee acknowledges and agrees that Licensee is prohibited from doing any act that may have the effect of undermining the integrity of the Platform, Services, any related computer systems, infrastructure or environment, or the methods by which Veritone provides Services to users. Without limiting the generality of the foregoing, Licensee agrees that it shall not, directly or indirectly: (i) defeat, circumvent or modify any authentication technology or other security measures, controls, limitations, or content or functionality filters contained in or associated with the Platform or Services, or otherwise attempt to access any aspect of the Platform or Services that Licensee has not been granted authorization to access under the License Agreement; (ii) deploy or facilitate the use or deployment of any script, routine, robot, spider, scraper or any other automated means, method or device with respect to Licensee's access and use of the Platform and Services for any purpose, including to access, view, select, or copy in whole or in part, any content, program, functionality of the Platform or Services, or any other proprietary information or trade secret of Veritone that is made available through the Platform or Services; (iii) deploy or facilitate the use or deployment of any program, system, means, method or device, for any purpose that places an unreasonable, unnecessary or excessive demand or load on the Platform, Services, or related hardware and connections, or prohibits, denies or delays access to Services by other users or otherwise threatens the continuous services of Veritone's ISPs, suppliers and vendors; (iv) introduce into the Platform or Services any program, executable file or routine (such as a worm, Trojan horse, cancel-bot, time bomb or virus) irrespective of whether any such program or routine results in detrimental harm to the Platform, Services, or any underlying systems or programs; (v) remove any proprietary notices, labels or marks from the Platform or Services; (vi) establish any direct or deep link or other connection to any specific page or location within the Platform or Services, other than the Platform log-in page; (vii) use or attempt to use another user's account without authorization, or interfere with another user's access to the Platform or Services; or (viii) access or use the Platform or Services to design, develop, build, market or support a competitive product or service.

3. Access and Use. Veritone will enable Licensee to access and use the Platform for the duration of the Term, subject to any early termination of this Agreement in accordance with the terms hereof. Access to the Platform will be through unique log-in credentials assigned to Licensee by Veritone (each, a "User ID"). Licensee shall be given that number of User IDs as specified in the License Agreement. Licensee will provide accurate and complete information in registering its authorized users for account access. Licensee acknowledges and agrees that the log-in credentials assigned hereunder are Confidential Information and may only be used by Licensee and its authorized users to access the Platform in accordance with the terms of this Agreement, and that Licensee will not publish, share, or otherwise enable any third party, directly or indirectly, to access the Platform for any purpose. Licensee further agrees that Licensee is responsible for its and its authorized users' use of the Platform, including use via the User IDs, and for any consequences thereof. Licensee agrees to immediately notify Veritone of any unauthorized or improper use of any log-in credentials of Licensee. All of the rights, obligations, restrictions, representations and warranties related to Licensee's access and use of the Platform under this Agreement shall apply to Licensee and all of Licensee's employees, contractors, consultants, representatives and agents (collectively, "Representatives"). Licensee shall be responsible for all acts and omissions of its Representatives in the performance of this Agreement and for any breach of this Agreement by any of its Representatives.

4. Intellectual Property.

4.1. Veritone Property. As between Veritone and Licensee, Veritone and/or its respective licensors retain all right, title and interest (including Intellectual Property Rights) in and to the Platform and Services, including, but not limited to any

elements, components, content, technology, software, code, documentation, derivative works, revisions, enhancements, modifications, condensations and/or compilations of or relating to the Platform and Services, and any trademarks, brand identifiers, materials and information, which are created, authored, developed, conceived and/or reduced to practice by Veritone and/or its respective licensors, including in connection with Veritone's provision of the Platform and Services to Licensee under this Agreement ("**Veritone Property**").

4.2. Licensee Property. As between Licensee and Veritone, Licensee retains all right, title and interest (including Intellectual Property Rights) in and to the Licensee Content, and any software, technology, trademarks, brand identifiers, materials and information which are independently created, authored, developed, conceived or reduced to practice by Licensee.

5. Licensee Content.

5.1. Content Ownership. Licensee represents and warrants that (i) Licensee and/or its licensors own all right, title and interest in and to all Licensee Content uploaded to or transmitted through the Platform or Services, or otherwise have all rights in such Licensee Content as necessary to use the same in connection with Licensee's use of the Platform and Services, (ii) such Licensee Content does not and will not misappropriate or infringe upon any third party's Intellectual Property Rights, or violate any other rights of any third party, and (iii) Licensee has all rights in such Licensee Content necessary to grant the rights contemplated by this Agreement.

5.2. License to Content. Unless otherwise specified in the License Agreement, Licensee hereby grants to Veritone a non-exclusive, royalty-free, worldwide license (i) to use and display all Licensee Content that Licensee provides to Veritone or that are otherwise uploaded to or captured by the Platform through Licensee's use of the Platform and Services to provide the Services and perform its obligations under this Agreement, directly or through its third party service providers, and (ii) to share such Licensee Content with Veritone's third party service providers solely as required for Veritone's provision of the Platform and Services to Licensee.

5.3. Data Security and Destruction. Veritone will maintain and use adequate administrative, physical, and technical safeguards for protection of the security, confidentiality and integrity of all Licensee Content uploaded to or transmitted through the Platform or Services. Licensee Content shall be used and stored by Veritone solely to the extent required to provide the Services and perform its obligations under this Agreement or as otherwise expressly provided in the License Agreement, and Veritone shall not use or store the Licensee Content for any other purpose whatsoever. Upon termination of this Agreement or upon the written request of Licensee at any time, Veritone shall ensure the secure deletion and destruction of all Licensee Content.

6. Feedback. During the Term, Licensee may provide Veritone with such written evaluations, comments and/or suggestions (collectively, "**Feedback**") regarding the Platform or Services. Licensee acknowledges and agrees that any Feedback provided to Veritone by Licensee hereunder shall be deemed to be Veritone Property and Licensee hereby assigns all right, title and interest in and to such Feedback to Veritone and acknowledges that Veritone will be entitled to, without limitation, implement and exploit any such Feedback in any manner without any restriction or obligation. Notwithstanding the foregoing, Licensee acknowledges that Veritone is not obligated to act on any such Feedback.

7. Term and Termination.

7.1. Term. The term of this Agreement and the License shall be as set forth in the License Agreement (the "**Term**").

7.2. Termination. In addition to any termination rights expressly provided in the License Agreement, this Agreement may be terminated by either party if the other party (i) materially breaches any provision of this Agreement which remains uncured for a period of fourteen (14) days from the date of written notice of such breach; or (ii) makes an assignment for the benefit of its creditors, is declared insolvent, or has a receiver or trustee in bankruptcy appointed to take charge of all or part of such party's property.

7.3. Effect of Termination. If at any time this Agreement is terminated, or upon expiration of the Term, the License and all other rights granted to Licensee herein shall automatically terminate and Licensee shall immediately cease using the Platform and Services.

7.4. Survival. The provisions of Sections 2.2 (Reservation of Rights), 4 (Intellectual Property), 6 (Feedback), 7.3 (Effect of Termination), 8.1 (Fees and Payments), 8.2 (Taxes), 10 (Confidentiality), 11 (Indemnification), 12.2 and 12.3 (Warranty and Disclaimers), 13 (Limitation of Liability), 14 (Miscellaneous) hereof and the payment terms of License Agreement, as applicable, shall survive the expiration or any early termination of this Agreement for any reason.

8. Fees, Charges and Payments.

8.1. Fees and Payments. In consideration for the License and Licensee's access and use of the Platform and Services, Licensee shall pay the license fees, and any applicable additional fees, as set forth in the License Agreement (collectively, the "Fees"). All Fees and other amounts due under this Agreement are payable in U.S. dollars.

8.2. Taxes. All Fees and any other amounts due hereunder are exclusive of taxes and similar assessments which may be imposed on the delivery of the Platform and Services and any other transactions contemplated hereby. Licensee shall be solely responsible for the payment of any and all sales, use, value added, excise, import, or other similar taxes or payments in lieu thereof, including interest and penalties thereon, imposed by any authority, government or governmental agency arising out of or in connection with amounts due hereunder (other than those levied on Veritone's income), and Licensee shall make such payments, and timely file any return or information required by treaty, law, rule or regulation. Upon request, Licensee shall provide Veritone with documentation evidencing such payments. If Veritone is required to pay any such taxes, duties or fees, Licensee shall reimburse Veritone immediately upon receipt of Veritone's invoice thereof.

8.3. Suspension of Platform Access. In addition to Veritone's termination rights set forth herein and without prejudice to any other rights of Veritone at law or in equity, Veritone may suspend its performance under this Agreement and any other agreement with Licensee and Licensee's access to the Platform if Licensee fails to comply with any part of its payment obligations set forth herein. Such suspension of service shall not suspend or otherwise affect Licensee's payment obligations set forth herein.

9. Changes to Platform, Service and Fees. Veritone may, from time to time, in its sole discretion, make changes to the Platform and Services, or a portion thereof including, without limitation, formats, content, reports, functionality, and/or techniques ("Service Change"). In the event of a Service Change, Veritone may, adjust the Fees for the Platform and Services ("Fee Change") in writing. Such Fee Change shall become effective on the date stated in Veritone's notice to Licensee unless, within fifteen (15) days after a Fee Change notice that would result in an increase in the Fees, Licensee notifies Veritone in writing of its refusal to accept the Fee Change, in which event the applicable License to Licensee shall terminate as of the effective date of the change; provided, however, that if the Fee Change is an increase in the Fees, Veritone may, in its sole discretion, elect to rescind the Fee Change, in which case the Platform and Services, as changed, shall continue as provided herein.

10. Confidentiality.

10.1. Confidential Information. Each party (a receiving party) acknowledges and agrees that during the Term and in the course of using the Platform and Services and performing its duties under this Agreement, it may obtain information relating to the other party (a disclosing party), its and/or its customers', vendors', or third party service providers' business or technologies, which is of a confidential and proprietary nature ("**Confidential Information**"). Such Confidential Information may include, but is not limited to, trade secrets, know-how, inventions, techniques, processes, software, algorithms, programs, schematics, data, technology roadmap, sales and marketing plans, and any other information which the receiving party knows or has reason to know is, or which by its nature would reasonably be considered to be, confidential, proprietary or trade secret information of the other party. Without limiting the foregoing, Confidential Information of Veritone shall include the Platform, Services and all associated software and documentation, as well as Feedback or any results of the evaluation or testing of the Platform or Services. The receiving party shall at all times, both during the Term and for a period of three (3) years after its termination (or, in the case of the Platform, Services and any associated software or trade secrets, in perpetuity), keep in trust and confidence all Confidential Information of the disclosing party, and shall not (i) use such Confidential Information other than as expressly authorized under this Agreement or as required for the receiving party to perform its obligations under this Agreement, or (ii) disclose any Confidential Information of the disclosing party to third parties (other than to Veritone's third party service providers in connection with the performance of its obligations under this Agreement), without the disclosing party's prior written consent. The receiving party further agrees to immediately return to the disclosing party or destroy all Confidential Information (including all copies, extracts and summaries thereof) in the receiving party's possession, custody, or control upon the expiration or any termination of this Agreement. The obligations of confidentiality shall not apply to information which (a) has entered the public domain except where such entry is the result of the receiving party's breach of this Agreement; (b) prior to disclosure hereunder, was already in the receiving party's possession and not subject to any confidentiality obligations, as demonstrated by written evidence; (c) subsequent to disclosure hereunder is obtained by the receiving party on a non-confidential basis from a third party who has the right to disclose such information to the receiving party; or (d) has been independently developed by the receiving party without use of or reference to the disclosing party's Confidential Information, as demonstrated by written evidence.

10.2. Permitted Disclosures. The receiving party may make disclosures (i) as required by applicable law or the rules of an stock exchange on which such party's shares are then traded; or (ii) as compelled by court order issued by a court of competent

jurisdiction provided that the receiving party subject to such court order (a) provides the disclosing party with prompt written notice of any such compelled disclosure, (b) uses diligent reasonable efforts to limit disclosure, (c) uses commercially reasonable efforts to obtain confidential treatment or a protective order in connection with the information subject to such compelled disclosure, and (d) allows the disclosing party to participate in any such proceeding.

11. Indemnification.

11.1. Licensee Indemnification of Veritone. Licensee will defend, indemnify and hold harmless Veritone and its subsidiaries, affiliates, successors, assigns, licensors, and their respective members, officers, directors, employees, licensors, agents, from and against any liability or expense, including, without limitation, any expenses, losses, damages, judgments, litigation costs and reasonable attorneys' fees, that Veritone may incur as a result of any claim, suit or proceeding brought against Veritone by any third party arising or resulting from (a) Licensee's breach of any representation, warranty, covenant or obligation contained in this Agreement; or (b) Licensee's use of the Platform or Services (including uploading, using, publishing, posting or otherwise sharing of Licensee's Content or any other data or content derived from the Platform or Services) in any manner that violates this Agreement or any laws, rules, regulations or third party terms and conditions, or that misappropriates or infringes the rights (including Intellectual Property Rights) of any third party; *provided that* Veritone gives Licensee prompt notice of any such claims, cooperates with Licensee in responding to such claims, and permits Licensee to control the defense or settlement of such claims, subject to Veritone's right to (i) conduct the defense of such claims at Veritone's expense, or participate in the defense of such claims with its own counsel at its own expense, and (ii) approve any settlement that binds or purports to bind Veritone.

11.2. Veritone Indemnification of Licensee. Veritone will defend, indemnify and hold harmless Licensee and its subsidiaries, affiliates, successors, assigns, licensors, and their respective members, officers, directors, employees, licensors, agents, from and against any liability or expense, including without limitation, any expenses, losses, damages, judgments, litigation costs and reasonable attorneys' fees that Licensee may incur as a result of any claim, suit or proceeding brought against Licensee by any third party arising or resulting from (a) Veritone's breach of any representation, warranty, covenant or obligation contained in this Agreement; or (b) any allegation that the Platform or Services, or any part thereof, misappropriates or infringes upon any third party's Intellectual Property Rights, except to the extent such claims arise from Licensee's negligence, misconduct or violation of any terms of this Agreement; *provided that* Licensee gives Veritone prompt notice of any such claims, cooperates with Veritone in responding to such claims, and permits Veritone to control the defense or settlement of such claims, subject to Licensee's right to (i) conduct the defense of such claims at Licensee's expense, or participate in the defense of such claims with its own counsel at its own expense, and (ii) approve any settlement that binds or purports to bind Licensee. If the Platform, in whole in part, becomes or, in Veritone's opinion is likely to become, the subject of an infringement claim or action, Veritone may, at its option: (x) procure, at no cost to Licensee, the right for Licensee to continue using the Platform; (y) replace or modify the Platform to render the Platform non-infringing, provided there is no material loss of functionality; or (z) if, in Veritone's reasonable opinion, neither (x) nor (y) above is commercially feasible, terminate this Agreement and refund any prepaid amounts for unused Services during the terminated portion of the Term. The foregoing states Veritone's sole obligation and Licensee's exclusive remedy in the event any such infringement claim or action is commenced or is likely to be commenced.

12. Warranties and Disclaimers.

12.1. Mutual Warranties. Each party represents and warrants to the other that: (i) it is duly organized and validly existing under the laws of the jurisdiction of its incorporation or formation, and has full power, rights and authority to enter into this Agreement and carry out its obligations hereunder; (ii) the person executing this Agreement is authorized to do so on its behalf; (iii) this Agreement is valid and legally binding upon it and (iv) the execution, delivery and performance thereof by such party does not conflict with any other agreement, instrument or understanding to which it is a party or by which it may be bound, nor would violate any applicable law or regulation.

12.2. Disclaimer. THE PLATFORM, SERVICES AND ANY OTHER VERITONE PRODUCTS AND SERVICES ARE PROVIDED ON AN "AS IS" AND "AS AVAILABLE" BASIS. EXCEPT AS EXPRESSLY PROVIDED IN THIS AGREEMENT, VERITONE MAKES NO WARRANTY, EXPRESS OR IMPLIED, WITH RESPECT TO THE PLATFORM AND SERVICES, INCLUDING, WITHOUT LIMITATION, ANY WARRANTY AS TO THE ACCURACY OF PROCESSING RESULTS, ANY WARRANTY OF MERCHANTABILITY, QUALITY OR FITNESS FOR A PARTICULAR PURPOSE, WARRANTIES ARISING FROM COURSE OF DEALING OR USAGE OF TRADE, AND WARRANTIES OF NON-INFRINGEMENT. VERITONE DOES NOT WARRANT THAT THE PLATFORM AND SERVICES ARE ERROR-FREE, WILL RUN UNINTERRUPTED, OR THAT ALL ERRORS CAN OR WILL BE CORRECTED. NO ADVICE OR INFORMATION, WHETHER ORAL OR WRITTEN, OBTAINED BY LICENSEE FROM VERITONE SHALL CREATE ANY SUCH WARRANTY.

12.3. LICENSEE ACKNOWLEDGES AND AGREES THAT THE INTERNET IS A PUBLIC NETWORK OVER WHICH VERITONE EXERTS NO CONTROL. VERITONE MAKES NO REPRESENTATIONS OR WARRANTIES WHATSOEVER, AND SHALL HAVE NO LIABILITY WHATSOEVER, WITH RESPECT TO THE ACCURACY, DEPENDABILITY, PRIVACY, SECURITY, AUTHENTICITY OR COMPLETENESS OF DATA TRANSMITTED OVER OR OBTAINED USING THE INTERNET OUTSIDE OF THOSE SYSTEMS AND NETWORKS CONTROLLED BY VERITONE, OR ANY INTRUSION, VIRUS, DISRUPTION, LOSS OF COMMUNICATION, LOSS OR CORRUPTION OF DATA, OR OTHER ERROR OR EVENT CAUSED OR PERMITTED BY OR INTRODUCED THROUGH LICENSEE'S OWN USE OF THE INTERNET. LICENSEE IS SOLELY RESPONSIBLE FOR IMPLEMENTING ADEQUATE FIREWALL, PASSWORD AND OTHER SECURITY MEASURES TO PROTECT ITS SYSTEMS, DATA AND APPLICATIONS FROM UNWANTED INTRUSION, WHETHER OVER THE INTERNET OR BY OTHER MEANS.

13. Limitation of Liability.

13.1. EXCEPT FOR (A) BREACHES OF EACH PARTY'S OBLIGATIONS UNDER SECTION 10 (CONFIDENTIALITY), AND (B) AMOUNTS FINALLY AWARDED OR SETTLED IN A THIRD PARTY CLAIM FOR WHICH A PARTY IS RESPONSIBLE UNDER SECTION 11 (INDEMNIFICATION), NEITHER PARTY, INCLUDING ITS OFFICERS, DIRECTORS, EMPLOYEES, REPRESENTATIVES AND AFFILIATES, SHALL BE LIABLE FOR ANY INDIRECT, INCIDENTAL, SPECIAL, CONSEQUENTIAL, OR PUNITIVE DAMAGES, INCLUDING WITHOUT LIMITATION, LOST DATA OR LOST PROFITS, OR COSTS OF PROCURING SUBSTITUTE GOODS OR SERVICES, HOWEVER ARISING, EVEN IF IT HAS BEEN ADVISED OF THE POSSIBILITY OF SUCH DAMAGES.

13.2. EXCEPT WITH RESPECT TO EACH PARTY'S CONFIDENTIALITY AND INDEMNIFICATION OBLIGATIONS HEREUNDER, NEITHER PARTY'S LIABILITY FOR DAMAGES ARISING OUT OF, RELATING TO OR IN ANY WAY CONNECTED WITH THIS AGREEMENT SHALL EXCEED THE TOTAL FEES PAID BY LICENSEE TO VERITONE UNDER THIS AGREEMENT.

14. MISCELLANEOUS

14.1. No Assignment. Neither party may assign any of its rights or obligations under this Agreement without the prior written consent of the other party, except that either party may assign its rights and obligations under this Agreement without the consent of the other party to an affiliate directly or indirectly controlling, controlled by, or under direct or indirect common control with such party or in connection with any merger (by operation of law or otherwise), consolidation, reorganization, change in control or sale of all or substantially all of its assets related to this Agreement or similar transaction. This Agreement inures to the benefit of and shall be binding on the parties' permitted assignees, transferees and successors.

14.2. Severability. If any provision of this Agreement is found by a court of competent jurisdiction to be invalid, the parties nevertheless agree that the court should endeavor to give effect to the parties' intentions as reflected in such provision, and the other provisions of this Agreement remain in full force and effect.

14.3. No Waiver. The failure of either party to exercise or enforce any right or provision of this Agreement shall not constitute a waiver of such right or provision.

14.4. Controlling Law. This Agreement shall be governed by and construed in accordance with the laws of the State of California (other than the conflict of law rules) and subject to the sole jurisdiction of the courts sitting in Orange County, California. Notwithstanding the foregoing, nothing in this Section 14.4 shall be deemed to limit the parties' rights to seek injunctive relief in any other court of law of competent jurisdiction.

14.5. Independent Contractors. This Agreement does not create any relationship other than Veritone as an independent contractor performing services covered by this Agreement and Licensee as the party contracting with Veritone for those services. No party is a partner or a legal representative of the other for any purpose whatsoever, nor is any party authorized to make any contract, agreement or warranty on behalf of any other party. Under no circumstance shall one party's employees be construed to be employees of the other party.

14.6. Publicity. Except as required or compelled by applicable law, the rules of any stock exchange, or a court order issued by a court of competent jurisdiction, neither party will make any public statement regarding, or disclose, advertise or publish the terms and conditions of this Agreement without the prior written consent of the other party; provided, however, that Veritone may reference Licensee on Veritone's website, other marketing materials, investor relations materials, and as a customer in Veritone's SEC filings.

14.7. Notices. All notices to either party shall be in writing and delivered by hand or by certified mail or overnight delivery service to the address set forth by Licensee and/or Veritone in the License Agreement, or to such other address as either party shall provide by notice to the other party. Alternatively, the parties may, at their election, utilize email as the method of delivery of any such notice to be provided hereunder. Any such notices sent by email shall be delivered to the email addresses set forth in the License Agreement, or such other email address as designed by a party during the Term. Notices shall be deemed effective when delivered to the applicable address, unless any such notice is sent by

email, in which event, notice shall be deemed effective upon confirmation of delivery by a “read receipt” or other such notice generated by the applicable email system, but in any event, by reply of the recipient of such notice.

- 14.8. Electronic Communication.** In connection with its use of the Platform and Services, Licensee consents to receiving communications from Veritone electronically. Veritone will communicate with Licensee by e-mail or by posting notices on the Platform or through any Services. Licensee agrees that all notices, disclosures and other communications that Veritone provides to Licensee electronically satisfy any legal requirement that such communications be in writing.
- 14.9. Force Majeure.** Except for the obligation to make payments of any Fees or any other amounts due hereunder, neither party will be liable for any failure or delay in its performance under the Agreement due to any cause beyond such party’s control including acts of war, terrorism, acts of God, embargo, riot, sabotage, labor shortage or dispute, governmental act, or failure of the Internet, or any component comprising or operating the network infrastructure thereof (each, a “**Force Majeure Event**”), provided that the delayed party: (i) gives the other party prompt notice of such cause, and (ii) uses its reasonable commercial efforts to promptly correct such failure or delay in performance. If Veritone is unable to provide Service(s) for a period of sixty (60) consecutive days as a result of a continuing Force Majeure Event, either party may elect to terminate this Agreement.
- 14.10. Construction.** This Agreement shall be fairly interpreted and construed in accordance with its terms and without strict interpretation or construction in favor of or against either party. Each party has had the opportunity to consult with counsel in the negotiation of this Agreement.
- 14.11. Counterparts.** This Agreement may be executed in one or more counterparts (including fax or email) each of which shall be deemed an original but all of which taken together shall be deemed one and the same instrument.
- 14.12. Headings.** Unless otherwise expressly stated in this Agreement, the words “herein,” “hereof,” “hereto,” and “hereunder” and other words of similar import refer to this Agreement as a whole and not to any particular section, subsection, or other subdivision. The words “include” and “including” shall not be construed or interpreted as terms of limitation. The words “day,” “month,” and “year” mean, respectively, calendar day, calendar month, and calendar year. Section headings are for reference purposes only, and should not be used in the interpretation hereof.
- 14.13. Amendment.** No addendum, waiver, consent, modification, amendment or change of the terms of this Agreement shall bind either party unless in a writing that references this Agreement and is signed by duly authorized representatives of Licensee and Veritone.
- 14.14. Attorney’s Fees.** If any action arises under this Agreement, including, without limitation the interpretation or enforcement of any term of this Agreement, the prevailing party in any such action shall be entitled to recover its reasonable attorney’s fees and related costs.

**Veritone IDentify Application
Data Sharing Addendum**

This Data Sharing Addendum (“Addendum”) is entered into as of February __, 2019, by and between Veritone, Inc. (“Veritone”) and Irvine Police Department (“Licensee”). This Addendum is incorporated by reference into, made a part of and governed by the terms of the Pilot Evaluation License Agreement dated February __, 2019 between Veritone and Licensee (the “Agreement”). In the event of any conflict or inconsistency between the provisions contained in the Agreement and the provisions contained in this Addendum with respect to the subject matter hereof, the provisions of this Addendum shall govern and control. Capitalized terms used but not defined herein shall have the meanings ascribed to them in the Agreement.

1. **IDentify Application.** Veritone has granted to Licensee a right and license to access and use the IDentify Application within the Platform. The IDentify Application allows users to upload booking, arrest and known offender databases (collectively, “Booking Databases”) and use facial recognition technology to compare digital evidence from crime scenes with the Booking Databases to identify potential suspects. The IDentify Application also allows Licensee and other judicial and law enforcement agencies (each, an “Agency”) to elect to share access to their Booking Databases as further described in this Addendum (the “Data Sharing Option”).
2. **Participation in Data Sharing Option.** By executing this Addendum, Licensee hereby elects to participate in the Data Sharing Option, and each of Licensee and Veritone acknowledges and agrees to the supplemental terms and conditions applicable to the Data Sharing Option as set forth in this Addendum, in addition to the terms of the Agreement. All rights granted by each party under this Addendum shall continue during the Term of the Agreement, unless earlier terminated as set forth herein.
3. **Databases.**
 - (a) **Shared Databases.** Licensee will participate in the Data Sharing Option with respect to the Booking Databases indicated below (the option indicated below referred to hereinafter as the “Shared Databases”) (*check/complete one option*):
 - The Booking Databases maintained in the Platform by all other Agencies participating in the Data Sharing Option; or
 - The Booking Databases maintained in the Platform by the following Agencies:
 1. N/A
 - 2.
 - 3.
 - 4.
 - (b) **Access to Licensee Databases.** Licensee hereby grants to Veritone the right to grant access to all Booking Databases that Licensee maintains in the Platform (the “Licensee Databases”) to each other Agency that is participating in the Data Sharing Option and is maintaining a Shared Database in the Platform for use by each such Agency in connection with its use of the IDentify Application, and to other Agencies under limited trial licenses for evaluation purposes.
 - (c) **Access to Shared Databases.** Veritone will make available through the IDentify Application, and hereby grants to Licensee the right to access and use, the Shared Databases.
4. **Termination of Participation.** Licensee may terminate its participation in the Data Sharing Option by providing at least 60 days prior written notice to Veritone (or such shorter period as may be required by a court having jurisdiction). In such event, (i) Veritone will restrict access to the Licensee Databases to Licensee only and will terminate access to the Licensee Databases by any other Agency, and (ii) Veritone will terminate Licensee’s access to all Shared Databases, and Licensee’s use of the IDentify Application thereafter will be limited to use with the Licensee Databases only. Licensee acknowledges that Licensee’s right to access and use the Shared Databases is subject at all times to the participation by other Agencies in the Data Sharing Option on a continuous basis. If any Agency terminates its participation in the Data Sharing Option, Licensee will no longer

have access to the Shared Databases of such Agency or to any information generated from the Shared Databases associated with previously run searches and any resulting matches.

5. **Licensee Responsibilities.** Licensee shall be solely responsible for its use of the Shared Databases. Licensee represents and warrants that (a) it will use the Shared Databases solely in conjunction with its use of the IDentify Application in accordance with the terms of this Addendum, and (b) it will use the Shared Databases (including all data, content, materials, information and results contained in and/or generated from any of the foregoing) in compliance with all applicable laws, statutes, ordinances, rules, regulations, consent decrees, and/or requirements of any regulatory authority. Licensee shall defend, indemnify and hold harmless Veritone and its affiliates and licensors, and their respective members, officers, directors, employees, and agents, from and against any liability, losses, damages, judgments, costs and expenses, including litigation costs and reasonable attorneys' fees, arising out of or resulting from Licensee's use of the Shared Databases or Licensee's breach of any of its representations, warranties or obligations set forth in this Addendum.
6. **Authority.** The person executing this Addendum on behalf of each party represents and warrants that he or she has full authority to execute the same on behalf of such party, and that no other actions or approvals are required for such party to enter into this Addendum and perform its obligations hereunder.

IN WITNESS WHEREOF, the parties have caused this Addendum to be executed by their duly authorized representatives as of the date first above written.

VERITONE, INC.

Signature:

Name:

Title:

IRVINE POLICE DEPARTMENT

Signature:

Name:

Title:



PILOT EVALUATION LICENSE AGREEMENT

This Pilot Evaluation License Agreement ("Agreement") is entered into as of the date of the last signature below ("Effective Date") by and between Veritone, Inc. (for itself and/or its subsidiaries), having a principal office located at 575 Anton Boulevard, Suite 100, Costa Mesa, CA 92626 ("Veritone") and the entity listed under Licensee Information below ("Licensee"), with respect to license(s) to Veritone's aiWARE Platform and related Services.

Table with sections: LICENSEE INFORMATION (Agency Name, Address, Contact Name, Phone, Email), LICENSE AND SERVICES DETAILS (Term, Start Date, End Date, No. of Users, License Fees, Services, Cognitive Processing), and TERMS AND CONDITIONS.

- 1. Master License Terms and Conditions. This Agreement and Licensee's access to and use of the Platform and Services shall be governed by the Veritone Master License Terms and Conditions attached hereto as Attachment A and incorporated herein by reference (the "Terms and Conditions").
2. Identify Application and Cognitive Processing. During the Term, Veritone will provide Licensee with access to the IDentify Application and the cognitive processing specified above for content uploaded to the Platform by Licensee through the IDentify Application, for purposes of evaluation of the Platform and Services by Licensee.
3. Limitations. Licensee acknowledges that the IDentify Application is intended to be used by Licensee only as a tool to support review of digital evidence in connection with its investigations, and the IDentify Application and the results generated therefrom should not be considered or relied upon as a substitute for Licensee's customary investigative procedures, protocols and/or requirements.
4. Authority. The person executing this Agreement on behalf of each party represents and warrants that he or she has full authority to execute the same on behalf of such party, and that no other actions or approvals are required for such party to enter into this Agreement and perform its obligations hereunder.

Table with 2 columns: VERITONE, INC. and LICENSEE. Rows include Signature, Name, Title, and Date for both parties.

ATTACHMENT A

**VERITONE, INC. MASTER LICENSE TERMS AND CONDITIONS
(PS-Rev 20180907)**

(Attached)

VERITONE, INC.

MASTER LICENSE TERMS AND CONDITIONS

These Master License Terms and Conditions (“Terms and Conditions”) apply to any License Agreement (as defined below) between Veritone, Inc. (or one of its subsidiaries) (“Veritone”) and a licensee (“Licensee”).

- 1. License Agreement; Controlling Terms.** For purposes hereof, “License Agreement” shall mean the written license agreement, or the order form, subscription form, statement of work or other document, including any addenda or exhibits thereto, accepted by Veritone in writing, that evidences the purchase of a license from Veritone by the Licensee (either directly or through an authorized reseller of Veritone) to access and use the Veritone aiWARE Platform (the “Platform”) and associated Services (as defined below). The Platform is an artificial intelligence operating system that delivers near real-time media processing and analytics, enabling users to process, index, organize, manage, search, analyze and share audio, video and other data through a suite of applications and other services (collectively, the “Services”). The specific Services, content, fees and payment terms, number of authorized users, and the term of license shall be as set forth in the License Agreement. The License Agreement may also contain other license-specific terms and conditions. The License Agreement and these Terms and Conditions are collectively referred to herein as this “Agreement.” In the event of any conflict or inconsistency among the terms and conditions set forth in the License Agreement and in these Terms and Conditions, the rights and obligations of the parties shall be interpreted based on the following order of priority: (1) the License Agreement and (2) these Terms and Conditions. This Agreement constitutes the complete and exclusive agreement between the parties with respect to the Platform and Services, superseding and replacing any and all prior agreements, communications, and understandings, both written and oral, regarding such subject matter, and no additional or different provision contained in any purchase order form, order acknowledgment form, invoice or similar form of either party will be effective.
- 2. License, Reservation of Rights, Restrictions.**
 - 2.1. License.** Veritone hereby grants to Licensee, during the Term (as defined in Section 7 below), a non-transferable, non-sublicensable, non-exclusive, revocable license to access and use the Platform and Services, subject to the terms and conditions set forth in this Agreement (the “License”). Licensee agrees to use the Platform and Services only for its internal business purposes in accordance with the terms of this Agreement. For the avoidance of doubt, the Platform and Services and its content may not be displayed publicly; provided that, subject to the provisions of Section 2.4 (Restrictions) and Section 11 (Indemnification) of this Agreement, Licensee may post, publish or otherwise share its owned or licensed content via the Platform for which sharing capabilities are enabled during the Term in accordance with the terms of this Agreement.
 - 2.2. Reservation of Rights.** The Platform and Services are licensed by Veritone to Licensee, and not sold. Licensee acquires only the right to use the Platform and Services in accordance with this Agreement and does not acquire any rights of ownership. Nothing herein shall be construed to transfer any rights, title or ownership of any Veritone or Veritone-licensed software, technology, materials, information or Intellectual Property Rights to Licensee. All right, title and interest (including all Intellectual Property Rights) in and to the Platform and Services shall at all times remain the sole and exclusive property of Veritone and/or its respective licensors and all use thereof shall inure to the benefit of Veritone and/or its respective licensors. Except as expressly set forth in this Agreement, no right or license, express or implied, is granted to Licensee or any third party by estoppel, implication, exhaustion or other doctrine of law, equity or otherwise with respect to any product, service, software, technology, materials, information or Intellectual Property Rights of Veritone or its affiliates or licensors. “**Intellectual Property Rights**” means all forms of proprietary rights, titles, interests, and ownership including patents, patent rights, copyrights, trademarks, trade dresses, trade secrets, know-how, mask works, *droit moral* (moral rights), publicity rights and all similar rights of every type that may exist now or in the future in any jurisdiction, including without limitation all applications and registrations therefore and rights to apply for any of the foregoing.
 - 2.3. Third Party Licenses.** Certain software components of the Platform and Services are supplied pursuant to license agreements from third parties, and Licensee agrees that Licensee’s use of the Platform and Services shall be subject to the provisions of such third party license agreements.
 - 2.4. Restrictions.**
 - 2.4.1. License Restrictions.** Licensee agrees to use the Platform and Services only for lawful purposes and only as expressly authorized under this Agreement. Without limiting the generality of the foregoing, except as expressly authorized hereunder, Licensee agrees that it shall not, directly or indirectly: (i) license, sublicense, sell, resell, rent, lease, transfer, assign, distribute, display or otherwise make the Platform or Services, in whole or in part, including any content or data derived therefrom that is not directly owned by Licensee or for which Licensee has

all necessary rights, available to any third party, or use the Platform or Services to provide services to any third party; (ii) reverse engineer, decompile, disassemble, modify, translate, reconstruct, omit, distort, obscure, copy or create derivative works of all or any portion of the Platform, Services, any underlying software, or any other Veritone Property (as defined below), or otherwise attempt to access the source code of the Platform or Services; (iii) incorporate any portion of the Platform or Services into Licensee's own programs or compile any portion of them in combination with Licensee's own programs; (iv) store or otherwise capture to physical media, or enable a third party to store or capture, the Platform or Services or any portion thereof; (v) permit any persons, other than Licensee's authorized users for which Licensee has procured User IDs pursuant to the License Agreement, to access and use the Platform or Services; (vi) upload or transmit through the Platform or Services any material, content, media or data (collectively, "Licensee Content") with respect to which Licensee does not either own all right, title and interest or have the appropriate license(s) for lawful use, or otherwise violate or infringe upon the intellectual property rights of any third party in Licensee's use of the Platform or Services, including the use or distribution of any data derived from the Platform or Services; or (vii) violate any laws, rules or regulations in connection with its use of the Platform or Services, including any data or content contained in, transmitted through or derived therefrom.

2.4.2. Prohibited Acts. Licensee acknowledges and agrees that Licensee is prohibited from doing any act that may have the effect of undermining the integrity of the Platform, Services, any related computer systems, infrastructure or environment, or the methods by which Veritone provides Services to users. Without limiting the generality of the foregoing, Licensee agrees that it shall not, directly or indirectly: (i) defeat, circumvent or modify any authentication technology or other security measures, controls, limitations, or content or functionality filters contained in or associated with the Platform or Services, or otherwise attempt to access any aspect of the Platform or Services that Licensee has not been granted authorization to access under the License Agreement; (ii) deploy or facilitate the use or deployment of any script, routine, robot, spider, scraper or any other automated means, method or device with respect to Licensee's access and use of the Platform and Services for any purpose, including to access, view, select, or copy in whole or in part, any content, program, functionality of the Platform or Services, or any other proprietary information or trade secret of Veritone that is made available through the Platform or Services; (iii) deploy or facilitate the use or deployment of any program, system, means, method or device, for any purpose that places an unreasonable, unnecessary or excessive demand or load on the Platform, Services, or related hardware and connections, or prohibits, denies or delays access to Services by other users or otherwise threatens the continuous services of Veritone's ISPs, suppliers and vendors; (iv) introduce into the Platform or Services any program, executable file or routine (such as a worm, Trojan horse, cancel-bot, time bomb or virus) irrespective of whether any such program or routine results in detrimental harm to the Platform, Services, or any underlying systems or programs; (v) remove any proprietary notices, labels or marks from the Platform or Services; (vi) establish any direct or deep link or other connection to any specific page or location within the Platform or Services, other than the Platform log-in page; (vii) use or attempt to use another user's account without authorization, or interfere with another user's access to the Platform or Services; or (viii) access or use the Platform or Services to design, develop, build, market or support a competitive product or service.

3. Access and Use. Veritone will enable Licensee to access and use the Platform for the duration of the Term, subject to any early termination of this Agreement in accordance with the terms hereof. Access to the Platform will be through unique log-in credentials assigned to Licensee by Veritone (each, a "User ID"). Licensee shall be given that number of User IDs as specified in the License Agreement. Licensee will provide accurate and complete information in registering its authorized users for account access. Licensee acknowledges and agrees that the log-in credentials assigned hereunder are Confidential Information and may only be used by Licensee and its authorized users to access the Platform in accordance with the terms of this Agreement, and that Licensee will not publish, share, or otherwise enable any third party, directly or indirectly, to access the Platform for any purpose. Licensee further agrees that Licensee is responsible for its and its authorized users' use of the Platform, including use via the User IDs, and for any consequences thereof. Licensee agrees to immediately notify Veritone of any unauthorized or improper use of any log-in credentials of Licensee. All of the rights, obligations, restrictions, representations and warranties related to Licensee's access and use of the Platform under this Agreement shall apply to Licensee and all of Licensee's employees, contractors, consultants, representatives and agents (collectively, "Representatives"). Licensee shall be responsible for all acts and omissions of its Representatives in the performance of this Agreement and for any breach of this Agreement by any of its Representatives.

4. Intellectual Property.

4.1. Veritone Property. As between Veritone and Licensee, Veritone and/or its respective licensors retain all right, title and interest (including Intellectual Property Rights) in and to the Platform and Services, including, but not limited to any

elements, components, content, technology, software, code, documentation, derivative works, revisions, enhancements, modifications, condensations and/or compilations of or relating to the Platform and Services, and any trademarks, brand identifiers, materials and information, which are created, authored, developed, conceived and/or reduced to practice by Veritone and/or its respective licensors, including in connection with Veritone's provision of the Platform and Services to Licensee under this Agreement ("**Veritone Property**").

4.2. Licensee Property. As between Licensee and Veritone, Licensee retains all right, title and interest (including Intellectual Property Rights) in and to the Licensee Content, and any software, technology, trademarks, brand identifiers, materials and information which are independently created, authored, developed, conceived or reduced to practice by Licensee.

5. Licensee Content.

5.1. Content Ownership. Licensee represents and warrants that (i) Licensee and/or its licensors own all right, title and interest in and to all Licensee Content uploaded to or transmitted through the Platform or Services, or otherwise have all rights in such Licensee Content as necessary to use the same in connection with Licensee's use of the Platform and Services, (ii) such Licensee Content does not and will not misappropriate or infringe upon any third party's Intellectual Property Rights, or violate any other rights of any third party, and (iii) Licensee has all rights in such Licensee Content necessary to grant the rights contemplated by this Agreement.

5.2. License to Content. Unless otherwise specified in the License Agreement, Licensee hereby grants to Veritone a non-exclusive, royalty-free, worldwide license (i) to use and display all Licensee Content that Licensee provides to Veritone or that are otherwise uploaded to or captured by the Platform through Licensee's use of the Platform and Services to provide the Services and perform its obligations under this Agreement, directly or through its third party service providers, and (ii) to share such Licensee Content with Veritone's third party service providers solely as required for Veritone's provision of the Platform and Services to Licensee.

5.3. Data Security and Destruction. Veritone will maintain and use adequate administrative, physical, and technical safeguards for protection of the security, confidentiality and integrity of all Licensee Content uploaded to or transmitted through the Platform or Services. Licensee Content shall be used and stored by Veritone solely to the extent required to provide the Services and perform its obligations under this Agreement or as otherwise expressly provided in the License Agreement, and Veritone shall not use or store the Licensee Content for any other purpose whatsoever. Upon termination of this Agreement or upon the written request of Licensee at any time, Veritone shall ensure the secure deletion and destruction of all Licensee Content.

6. Feedback. During the Term, Licensee may provide Veritone with such written evaluations, comments and/or suggestions (collectively, "**Feedback**") regarding the Platform or Services. Licensee acknowledges and agrees that any Feedback provided to Veritone by Licensee hereunder shall be deemed to be Veritone Property and Licensee hereby assigns all right, title and interest in and to such Feedback to Veritone and acknowledges that Veritone will be entitled to, without limitation, implement and exploit any such Feedback in any manner without any restriction or obligation. Notwithstanding the foregoing, Licensee acknowledges that Veritone is not obligated to act on any such Feedback.

7. Term and Termination.

7.1. Term. The term of this Agreement and the License shall be as set forth in the License Agreement (the "**Term**").

7.2. Termination. In addition to any termination rights expressly provided in the License Agreement, this Agreement may be terminated by either party if the other party (i) materially breaches any provision of this Agreement which remains uncured for a period of fourteen (14) days from the date of written notice of such breach; or (ii) makes an assignment for the benefit of its creditors, is declared insolvent, or has a receiver or trustee in bankruptcy appointed to take charge of all or part of such party's property.

7.3. Effect of Termination. If at any time this Agreement is terminated, or upon expiration of the Term, the License and all other rights granted to Licensee herein shall automatically terminate and Licensee shall immediately cease using the Platform and Services.

7.4. Survival. The provisions of Sections 2.2 (Reservation of Rights), 4 (Intellectual Property), 6 (Feedback), 7.3 (Effect of Termination), 8.1 (Fees and Payments), 8.2 (Taxes), 10 (Confidentiality), 11 (Indemnification), 12.2 and 12.3 (Warranty and Disclaimers), 13 (Limitation of Liability), 14 (Miscellaneous) hereof and the payment terms of License Agreement, as applicable, shall survive the expiration or any early termination of this Agreement for any reason.

8. Fees, Charges and Payments.

8.1. Fees and Payments. In consideration for the License and Licensee's access and use of the Platform and Services, Licensee shall pay the license fees, and any applicable additional fees, as set forth in the License Agreement (collectively, the "Fees"). All Fees and other amounts due under this Agreement are payable in U.S. dollars.

8.2. Taxes. All Fees and any other amounts due hereunder are exclusive of taxes and similar assessments which may be imposed on the delivery of the Platform and Services and any other transactions contemplated hereby. Licensee shall be solely responsible for the payment of any and all sales, use, value added, excise, import, or other similar taxes or payments in lieu thereof, including interest and penalties thereon, imposed by any authority, government or governmental agency arising out of or in connection with amounts due hereunder (other than those levied on Veritone's income), and Licensee shall make such payments, and timely file any return or information required by treaty, law, rule or regulation. Upon request, Licensee shall provide Veritone with documentation evidencing such payments. If Veritone is required to pay any such taxes, duties or fees, Licensee shall reimburse Veritone immediately upon receipt of Veritone's invoice thereof.

8.3. Suspension of Platform Access. In addition to Veritone's termination rights set forth herein and without prejudice to any other rights of Veritone at law or in equity, Veritone may suspend its performance under this Agreement and any other agreement with Licensee and Licensee's access to the Platform if Licensee fails to comply with any part of its payment obligations set forth herein. Such suspension of service shall not suspend or otherwise affect Licensee's payment obligations set forth herein.

9. Changes to Platform, Service and Fees. Veritone may, from time to time, in its sole discretion, make changes to the Platform and Services, or a portion thereof including, without limitation, formats, content, reports, functionality, and/or techniques ("Service Change"). In the event of a Service Change, Veritone may, adjust the Fees for the Platform and Services ("Fee Change") in writing. Such Fee Change shall become effective on the date stated in Veritone's notice to Licensee unless, within fifteen (15) days after a Fee Change notice that would result in an increase in the Fees, Licensee notifies Veritone in writing of its refusal to accept the Fee Change, in which event the applicable License to Licensee shall terminate as of the effective date of the change; provided, however, that if the Fee Change is an increase in the Fees, Veritone may, in its sole discretion, elect to rescind the Fee Change, in which case the Platform and Services, as changed, shall continue as provided herein.

10. Confidentiality.

10.1. Confidential Information. Each party (a receiving party) acknowledges and agrees that during the Term and in the course of using the Platform and Services and performing its duties under this Agreement, it may obtain information relating to the other party (a disclosing party), its and/or its customers', vendors', or third party service providers' business or technologies, which is of a confidential and proprietary nature ("**Confidential Information**"). Such Confidential Information may include, but is not limited to, trade secrets, know-how, inventions, techniques, processes, software, algorithms, programs, schematics, data, technology roadmap, sales and marketing plans, and any other information which the receiving party knows or has reason to know is, or which by its nature would reasonably be considered to be, confidential, proprietary or trade secret information of the other party. Without limiting the foregoing, Confidential Information of Veritone shall include the Platform, Services and all associated software and documentation, as well as Feedback or any results of the evaluation or testing of the Platform or Services. The receiving party shall at all times, both during the Term and for a period of three (3) years after its termination (or, in the case of the Platform, Services and any associated software or trade secrets, in perpetuity), keep in trust and confidence all Confidential Information of the disclosing party, and shall not (i) use such Confidential Information other than as expressly authorized under this Agreement or as required for the receiving party to perform its obligations under this Agreement, or (ii) disclose any Confidential Information of the disclosing party to third parties (other than to Veritone's third party service providers in connection with the performance of its obligations under this Agreement), without the disclosing party's prior written consent. The receiving party further agrees to immediately return to the disclosing party or destroy all Confidential Information (including all copies, extracts and summaries thereof) in the receiving party's possession, custody, or control upon the expiration or any termination of this Agreement. The obligations of confidentiality shall not apply to information which (a) has entered the public domain except where such entry is the result of the receiving party's breach of this Agreement; (b) prior to disclosure hereunder, was already in the receiving party's possession and not subject to any confidentiality obligations, as demonstrated by written evidence; (c) subsequent to disclosure hereunder is obtained by the receiving party on a non-confidential basis from a third party who has the right to disclose such information to the receiving party; or (d) has been independently developed by the receiving party without use of or reference to the disclosing party's Confidential Information, as demonstrated by written evidence.

10.2. Permitted Disclosures. The receiving party may make disclosures (i) as required by applicable law or the rules of an stock exchange on which such party's shares are then traded; or (ii) as compelled by court order issued by a court of competent

jurisdiction provided that the receiving party subject to such court order (a) provides the disclosing party with prompt written notice of any such compelled disclosure, (b) uses diligent reasonable efforts to limit disclosure, (c) uses commercially reasonable efforts to obtain confidential treatment or a protective order in connection with the information subject to such compelled disclosure, and (d) allows the disclosing party to participate in any such proceeding.

11. Indemnification.

11.1. Licensee Indemnification of Veritone. Licensee will defend, indemnify and hold harmless Veritone and its subsidiaries, affiliates, successors, assigns, licensors, and their respective members, officers, directors, employees, licensors, agents, from and against any liability or expense, including, without limitation, any expenses, losses, damages, judgments, litigation costs and reasonable attorneys' fees, that Veritone may incur as a result of any claim, suit or proceeding brought against Veritone by any third party arising or resulting from (a) Licensee's breach of any representation, warranty, covenant or obligation contained in this Agreement; or (b) Licensee's use of the Platform or Services (including uploading, using, publishing, posting or otherwise sharing of Licensee's Content or any other data or content derived from the Platform or Services) in any manner that violates this Agreement or any laws, rules, regulations or third party terms and conditions, or that misappropriates or infringes the rights (including Intellectual Property Rights) of any third party; *provided that* Veritone gives Licensee prompt notice of any such claims, cooperates with Licensee in responding to such claims, and permits Licensee to control the defense or settlement of such claims, subject to Veritone's right to (i) conduct the defense of such claims at Veritone's expense, or participate in the defense of such claims with its own counsel at its own expense, and (ii) approve any settlement that binds or purports to bind Veritone.

11.2. Veritone Indemnification of Licensee. Veritone will defend, indemnify and hold harmless Licensee and its subsidiaries, affiliates, successors, assigns, licensors, and their respective members, officers, directors, employees, licensors, agents, from and against any liability or expense, including without limitation, any expenses, losses, damages, judgments, litigation costs and reasonable attorneys' fees that Licensee may incur as a result of any claim, suit or proceeding brought against Licensee by any third party arising or resulting from (a) Veritone's breach of any representation, warranty, covenant or obligation contained in this Agreement; or (b) any allegation that the Platform or Services, or any part thereof, misappropriates or infringes upon any third party's Intellectual Property Rights, except to the extent such claims arise from Licensee's negligence, misconduct or violation of any terms of this Agreement; *provided that* Licensee gives Veritone prompt notice of any such claims, cooperates with Veritone in responding to such claims, and permits Veritone to control the defense or settlement of such claims, subject to Licensee's right to (i) conduct the defense of such claims at Licensee's expense, or participate in the defense of such claims with its own counsel at its own expense, and (ii) approve any settlement that binds or purports to bind Licensee. If the Platform, in whole in part, becomes or, in Veritone's opinion is likely to become, the subject of an infringement claim or action, Veritone may, at its option: (x) procure, at no cost to Licensee, the right for Licensee to continue using the Platform; (y) replace or modify the Platform to render the Platform non-infringing, provided there is no material loss of functionality; or (z) if, in Veritone's reasonable opinion, neither (x) nor (y) above is commercially feasible, terminate this Agreement and refund any prepaid amounts for unused Services during the terminated portion of the Term. The foregoing states Veritone's sole obligation and Licensee's exclusive remedy in the event any such infringement claim or action is commenced or is likely to be commenced.

12. Warranties and Disclaimers.

12.1. Mutual Warranties. Each party represents and warrants to the other that: (i) it is duly organized and validly existing under the laws of the jurisdiction of its incorporation or formation, and has full power, rights and authority to enter into this Agreement and carry out its obligations hereunder; (ii) the person executing this Agreement is authorized to do so on its behalf; (iii) this Agreement is valid and legally binding upon it and (iv) the execution, delivery and performance thereof by such party does not conflict with any other agreement, instrument or understanding to which it is a party or by which it may be bound, nor would violate any applicable law or regulation.

12.2. Disclaimer. THE PLATFORM, SERVICES AND ANY OTHER VERITONE PRODUCTS AND SERVICES ARE PROVIDED ON AN "AS IS" AND "AS AVAILABLE" BASIS. EXCEPT AS EXPRESSLY PROVIDED IN THIS AGREEMENT, VERITONE MAKES NO WARRANTY, EXPRESS OR IMPLIED, WITH RESPECT TO THE PLATFORM AND SERVICES, INCLUDING, WITHOUT LIMITATION, ANY WARRANTY AS TO THE ACCURACY OF PROCESSING RESULTS, ANY WARRANTY OF MERCHANTABILITY, QUALITY OR FITNESS FOR A PARTICULAR PURPOSE, WARRANTIES ARISING FROM COURSE OF DEALING OR USAGE OF TRADE, AND WARRANTIES OF NON-INFRINGEMENT. VERITONE DOES NOT WARRANT THAT THE PLATFORM AND SERVICES ARE ERROR-FREE, WILL RUN UNINTERRUPTED, OR THAT ALL ERRORS CAN OR WILL BE CORRECTED. NO ADVICE OR INFORMATION, WHETHER ORAL OR WRITTEN, OBTAINED BY LICENSEE FROM VERITONE SHALL CREATE ANY SUCH WARRANTY.

12.3. LICENSEE ACKNOWLEDGES AND AGREES THAT THE INTERNET IS A PUBLIC NETWORK OVER WHICH VERITONE EXERTS NO CONTROL. VERITONE MAKES NO REPRESENTATIONS OR WARRANTIES WHATSOEVER, AND SHALL HAVE NO LIABILITY WHATSOEVER, WITH RESPECT TO THE ACCURACY, DEPENDABILITY, PRIVACY, SECURITY, AUTHENTICITY OR COMPLETENESS OF DATA TRANSMITTED OVER OR OBTAINED USING THE INTERNET OUTSIDE OF THOSE SYSTEMS AND NETWORKS CONTROLLED BY VERITONE, OR ANY INTRUSION, VIRUS, DISRUPTION, LOSS OF COMMUNICATION, LOSS OR CORRUPTION OF DATA, OR OTHER ERROR OR EVENT CAUSED OR PERMITTED BY OR INTRODUCED THROUGH LICENSEE'S OWN USE OF THE INTERNET. LICENSEE IS SOLELY RESPONSIBLE FOR IMPLEMENTING ADEQUATE FIREWALL, PASSWORD AND OTHER SECURITY MEASURES TO PROTECT ITS SYSTEMS, DATA AND APPLICATIONS FROM UNWANTED INTRUSION, WHETHER OVER THE INTERNET OR BY OTHER MEANS.

13. Limitation of Liability.

13.1. EXCEPT FOR (A) BREACHES OF EACH PARTY'S OBLIGATIONS UNDER SECTION 10 (CONFIDENTIALITY), AND (B) AMOUNTS FINALLY AWARDED OR SETTLED IN A THIRD PARTY CLAIM FOR WHICH A PARTY IS RESPONSIBLE UNDER SECTION 11 (INDEMNIFICATION), NEITHER PARTY, INCLUDING ITS OFFICERS, DIRECTORS, EMPLOYEES, REPRESENTATIVES AND AFFILIATES, SHALL BE LIABLE FOR ANY INDIRECT, INCIDENTAL, SPECIAL, CONSEQUENTIAL, OR PUNITIVE DAMAGES, INCLUDING WITHOUT LIMITATION, LOST DATA OR LOST PROFITS, OR COSTS OF PROCURING SUBSTITUTE GOODS OR SERVICES, HOWEVER ARISING, EVEN IF IT HAS BEEN ADVISED OF THE POSSIBILITY OF SUCH DAMAGES.

13.2. EXCEPT WITH RESPECT TO EACH PARTY'S CONFIDENTIALITY AND INDEMNIFICATION OBLIGATIONS HEREUNDER, NEITHER PARTY'S LIABILITY FOR DAMAGES ARISING OUT OF, RELATING TO OR IN ANY WAY CONNECTED WITH THIS AGREEMENT SHALL EXCEED THE TOTAL FEES PAID BY LICENSEE TO VERITONE UNDER THIS AGREEMENT.

14. MISCELLANEOUS

14.1. No Assignment. Neither party may assign any of its rights or obligations under this Agreement without the prior written consent of the other party, except that either party may assign its rights and obligations under this Agreement without the consent of the other party to an affiliate directly or indirectly controlling, controlled by, or under direct or indirect common control with such party or in connection with any merger (by operation of law or otherwise), consolidation, reorganization, change in control or sale of all or substantially all of its assets related to this Agreement or similar transaction. This Agreement inures to the benefit of and shall be binding on the parties' permitted assignees, transferees and successors.

14.2. Severability. If any provision of this Agreement is found by a court of competent jurisdiction to be invalid, the parties nevertheless agree that the court should endeavor to give effect to the parties' intentions as reflected in such provision, and the other provisions of this Agreement remain in full force and effect.

14.3. No Waiver. The failure of either party to exercise or enforce any right or provision of this Agreement shall not constitute a waiver of such right or provision.

14.4. Controlling Law. This Agreement shall be governed by and construed in accordance with the laws of the State of California (other than the conflict of law rules) and subject to the sole jurisdiction of the courts sitting in Orange County, California. Notwithstanding the foregoing, nothing in this Section 14.4 shall be deemed to limit the parties' rights to seek injunctive relief in any other court of law of competent jurisdiction.

14.5. Independent Contractors. This Agreement does not create any relationship other than Veritone as an independent contractor performing services covered by this Agreement and Licensee as the party contracting with Veritone for those services. No party is a partner or a legal representative of the other for any purpose whatsoever, nor is any party authorized to make any contract, agreement or warranty on behalf of any other party. Under no circumstance shall one party's employees be construed to be employees of the other party.

14.6. Publicity. Except as required or compelled by applicable law, the rules of any stock exchange, or a court order issued by a court of competent jurisdiction, neither party will make any public statement regarding, or disclose, advertise or publish the terms and conditions of this Agreement without the prior written consent of the other party; provided, however, that Veritone may reference Licensee on Veritone's website, other marketing materials, investor relations materials, and as a customer in Veritone's SEC filings.

14.7. Notices. All notices to either party shall be in writing and delivered by hand or by certified mail or overnight delivery service to the address set forth by Licensee and/or Veritone in the License Agreement, or to such other address as either party shall provide by notice to the other party. Alternatively, the parties may, at their election, utilize email as the method of delivery of any such notice to be provided hereunder. Any such notices sent by email shall be delivered to the email addresses set forth in the License Agreement, or such other email address as designed by a party during the Term. Notices shall be deemed effective when delivered to the applicable address, unless any such notice is sent by

email, in which event, notice shall be deemed effective upon confirmation of delivery by a “read receipt” or other such notice generated by the applicable email system, but in any event, by reply of the recipient of such notice.

- 14.8. Electronic Communication.** In connection with its use of the Platform and Services, Licensee consents to receiving communications from Veritone electronically. Veritone will communicate with Licensee by e-mail or by posting notices on the Platform or through any Services. Licensee agrees that all notices, disclosures and other communications that Veritone provides to Licensee electronically satisfy any legal requirement that such communications be in writing.
- 14.9. Force Majeure.** Except for the obligation to make payments of any Fees or any other amounts due hereunder, neither party will be liable for any failure or delay in its performance under the Agreement due to any cause beyond such party’s control including acts of war, terrorism, acts of God, embargo, riot, sabotage, labor shortage or dispute, governmental act, or failure of the Internet, or any component comprising or operating the network infrastructure thereof (each, a “**Force Majeure Event**”), provided that the delayed party: (i) gives the other party prompt notice of such cause, and (ii) uses its reasonable commercial efforts to promptly correct such failure or delay in performance. If Veritone is unable to provide Service(s) for a period of sixty (60) consecutive days as a result of a continuing Force Majeure Event, either party may elect to terminate this Agreement.
- 14.10. Construction.** This Agreement shall be fairly interpreted and construed in accordance with its terms and without strict interpretation or construction in favor of or against either party. Each party has had the opportunity to consult with counsel in the negotiation of this Agreement.
- 14.11. Counterparts.** This Agreement may be executed in one or more counterparts (including fax or email) each of which shall be deemed an original but all of which taken together shall be deemed one and the same instrument.
- 14.12. Headings.** Unless otherwise expressly stated in this Agreement, the words “herein,” “hereof,” “hereto,” and “hereunder” and other words of similar import refer to this Agreement as a whole and not to any particular section, subsection, or other subdivision. The words “include” and “including” shall not be construed or interpreted as terms of limitation. The words “day,” “month,” and “year” mean, respectively, calendar day, calendar month, and calendar year. Section headings are for reference purposes only, and should not be used in the interpretation hereof.
- 14.13. Amendment.** No addendum, waiver, consent, modification, amendment or change of the terms of this Agreement shall bind either party unless in a writing that references this Agreement and is signed by duly authorized representatives of Licensee and Veritone.
- 14.14. Attorney’s Fees.** If any action arises under this Agreement, including, without limitation the interpretation or enforcement of any term of this Agreement, the prevailing party in any such action shall be entitled to recover its reasonable attorney’s fees and related costs.

From: Noelle Smiley
Sent: Tuesday, February 19, 2019 10:54 AM PST
To: Mark Anderson
Subject: FW: Veritone pilot agreement
Attachments: Irvine PD Data Sharing Addendum (20190214).docx,
Irvine Police Department Trial License Agreement (IDentify) (20190214).docx,
Master License Terms and Conditions (PS Rev 20180907).pdf, image001.png, image002.png

Cindy will get this to their admin secretaries for fast distribution. Or so I'm told....

From: Mark Anderson
Sent: Tuesday, February 19, 2019 7:25 AM
To: Noelle Smiley <nsmiley@cityofirvine.org>
Subject: FW: Veritone pilot agreement

Commander,

Attached is the revised contract with Veritone reference the trial period T&E for the facial recognition software. Would you like me to send it to the City Attorney's Office for review?

Thanks

Mark

From: William Hillyard
Sent: Friday, February 15, 2019 1:48 PM
To: Mark Anderson <manderson@cityofirvine.org>
Subject: FW: Veritone pilot agreement

LT,

Here is the revised License Agreement for your review. As we discussed, they have changed the wording, and in fact changed the title of the document all together. The document is now "Pilot Evaluation License Agreement" with an end date of May 30, 2019. The license fee is "Waived for pilot evaluation" and there is no mention anywhere in any of the new documentation of a cost for an ongoing license for the software if we decided to move forward with making a purchase. As we've talked about, not having any idea of a pricing structure is not ideal, but I don't believe even at this point that Veritone themselves have any clue what to charge for an annual license for this software. The agreement we would be signing here is the same agreement Station 18 and Anaheim PD are operating under.

Please let me know if you have any question regarding the new documents.

Thank you,



William Hillyard | Detective | Irvine Police Department
949-724-7085 | 1 Civic Center Plaza, Irvine, CA 92606
whillyard@cityofirvine.org | cityofirvine.org

From: Tom Avery <tavery@veritone.com>
Sent: Friday, February 15, 2019 6:17 AM
To: William Hillyard <whillyard@cityofirvine.org>
Subject: Re: Veritone pilot agreement

Bill,

The updated pilot agreement is attached for your departments review. Let me know if you have any questions and have a good weekend.

Tom

From: William Hillyard <whillyard@cityofirvine.org>
Date: Thursday, February 14, 2019 at 12:27 PM
To: Tom Avery <tavery@veritone.com>
Subject: Re: Veritone pilot agreement

Hi Tom. Just checking in on the status of the revised quote?

Hope you're having a good/dry day.

Sent from my iPhone

On Feb 5, 2019, at 2:37 PM, Tom Avery <tavery@veritone.com> wrote:

Copy.

On Tue, Feb 5, 2019, 14:36 William Hillyard <whillyard@cityofirvine.org> wrote:

I just tried to call your cell. Measure S
[REDACTED] I'll probably be there for at least an hour.

Sent from my iPhone

On Feb 5, 2019, at 2:19 PM, Tom Avery <tavery@veritone.com> wrote:

I'll be in route to the Starbucks in about 10. Driving time from Irvine.

On Tue, Feb 5, 2019, 14:15 William Hillyard <whillyard@cityofirvine.org> wrote:

I'm around today. [REDACTED]

Investigation [REDACTED]

that doesn't work I'll be in tomorrow at 10am. Feel free to call me at [REDACTED] Privacy [REDACTED] anytime. I'd like to try and get an answer to the LT by late today or tomorrow AM because they have the command staff meeting tomorrow where they probably want to present the agreement to the Chief.

Thanks,



William Hillyard | Detective | Irvine Police Department
949-724-7085 | 1 Civic Center Plaza, Irvine, CA 92606
whillyard@cityofirvine.org | cityofirvine.org

From: Tom Avery <tavery@veritone.com>
Sent: Tuesday, February 05, 2019 1:46 PM
To: William Hillyard <whillyard@cityofirvine.org>
Subject: Re: FW: Veritone pilot agreement

This was news to me as well. I stopped by HQ but you must be out on assignment. Let me know when you have some time to talk and I'll drop by.

Tom

On Tue, Feb 5, 2019, 12:52 William Hillyard <whillyard@cityofirvine.org> wrote:

Tom,

Can you please see the question below from Lt. Anderson. In the agreement it states the waived fee is \$15,000 per month, is that meant to be per year for the license fee we discussed in the meeting?

Thank you,



William Hillyard | Detective | Irvine Police Department
949-724-7085 | 1 Civic Center Plaza, Irvine, CA 92606
whillyard@cityofirvine.org | cityofirvine.org

From: Mark Anderson <manderson@cityofirvine.org>
Sent: Monday, February 04, 2019 2:18 PM
To: William Hillyard <whillyard@cityofirvine.org>
Subject: FW: Veritone pilot agreement

Hi Sir. In the License Agreement attached it talked about 15,000 per month, but it's waived? Just not clear what that means. Can you take and look at it and explain or reach out to Veritone and ask for an explanation. Thank you

From: William Hillyard
Sent: Thursday, January 31, 2019 8:13 AM
To: Mark Anderson <manderson@cityofirvine.org>
Subject: FW: Veritone pilot agreement

LT,

Attached are the documents for the Pilot Program agreement with Veritone that need Chief Hamel's signature. Here are some brief points regarding the agreements:

- Irvine PD can opt out of the data sharing portion of the software at any time. If we did opt out but continued to use the software the suspect photos would only be compared to our database of known offenders, and no other agencies would have access to our database of booking photos and known offenders.
- The free trial period for the Pilot Program is 90 days, not 60 as was discussed during our meeting with Veritone.
- The initial License Agreement states that we will have (5) user profiles. This is only for the term of the Pilot Program. If we go forward with purchasing the software we will have an unlimited number of user licenses.
- Section 5.3 of the Master License Terms and Conditions states that if we cancel our relationship with Veritone any data we have provided them is removed from their servers and deleted. There are several portions throughout the agreements which clearly spell out that the data provided by Irvine PD remains the property of Irvine PD and should we terminated our contract with them they have no rights to retain or continue to use any data we provided them.
- The data we are providing other agencies access to through Veritone is no different than the data we upload to Coplink on a daily basis.
- For the Pilot Program we will provide Veritone with an initial data dump of our current database of booking photos, if we go forward with purchasing the software Veritone can set up and automated upload of new booking photos so there is no additional workload for our personnel.

I spoke with Nick Rycroft Monday reference the IT portion of it and he stated when the agreement is signed by the Chief he would begin working on the data export as requested by Veritone.

Please let me know if can provide any additional information.

Thank you,

Bill Hillyard

Begin forwarded message:

From: Tom Avery <tavery@veritone.com>
Date: January 30, 2019 at 7:15:09 AM PST
To: William Hillyard <whillyard@cityofirvine.org>
Subject: Veritone pilot agreement

Bill,

Attached is the Veritone pilot agreement documents which also include the terms and conditions as well as the data sharing agreement. Let me know if you have any questions.

Thanks,
Tom

Tom Avery
Vice President Public Safety
Veritone Government
tavery@veritone.com

Privacy cell

**Veritone IDentify Application
Data Sharing Addendum**

This Data Sharing Addendum (“Addendum”) is entered into as of February __, 2019, by and between Veritone, Inc. (“Veritone”) and Irvine Police Department (“Licensee”). This Addendum is incorporated by reference into, made a part of and governed by the terms of the Pilot Evaluation License Agreement dated February __, 2019 between Veritone and Licensee (the “Agreement”). In the event of any conflict or inconsistency between the provisions contained in the Agreement and the provisions contained in this Addendum with respect to the subject matter hereof, the provisions of this Addendum shall govern and control. Capitalized terms used but not defined herein shall have the meanings ascribed to them in the Agreement.

1. **IDentify Application.** Veritone has granted to Licensee a right and license to access and use the IDentify Application within the Platform. The IDentify Application allows users to upload booking, arrest and known offender databases (collectively, “Booking Databases”) and use facial recognition technology to compare digital evidence from crime scenes with the Booking Databases to identify potential suspects. The IDentify Application also allows Licensee and other judicial and law enforcement agencies (each, an “Agency”) to elect to share access to their Booking Databases as further described in this Addendum (the “Data Sharing Option”).
2. **Participation in Data Sharing Option.** By executing this Addendum, Licensee hereby elects to participate in the Data Sharing Option, and each of Licensee and Veritone acknowledges and agrees to the supplemental terms and conditions applicable to the Data Sharing Option as set forth in this Addendum, in addition to the terms of the Agreement. All rights granted by each party under this Addendum shall continue during the Term of the Agreement, unless earlier terminated as set forth herein.
3. **Databases.**
 - (a) **Shared Databases.** Licensee will participate in the Data Sharing Option with respect to the Booking Databases indicated below (the option indicated below referred to hereinafter as the “Shared Databases”) (*check/complete one option*):
 - The Booking Databases maintained in the Platform by all other Agencies participating in the Data Sharing Option; or
 - The Booking Databases maintained in the Platform by the following Agencies:
 1. N/A
 - 2.
 - 3.
 - 4.
 - (b) **Access to Licensee Databases.** Licensee hereby grants to Veritone the right to grant access to all Booking Databases that Licensee maintains in the Platform (the “Licensee Databases”) to each other Agency that is participating in the Data Sharing Option and is maintaining a Shared Database in the Platform for use by each such Agency in connection with its use of the IDentify Application, and to other Agencies under limited trial licenses for evaluation purposes.
 - (c) **Access to Shared Databases.** Veritone will make available through the IDentify Application, and hereby grants to Licensee the right to access and use, the Shared Databases.
4. **Termination of Participation.** Licensee may terminate its participation in the Data Sharing Option by providing at least 60 days prior written notice to Veritone (or such shorter period as may be required by a court having jurisdiction). In such event, (i) Veritone will restrict access to the Licensee Databases to Licensee only and will terminate access to the Licensee Databases by any other Agency, and (ii) Veritone will terminate Licensee’s access to all Shared Databases, and Licensee’s use of the IDentify Application thereafter will be limited to use with the Licensee Databases only. Licensee acknowledges that Licensee’s right to access and use the Shared Databases is subject at all times to the participation by other Agencies in the Data Sharing Option on a continuous basis. If any Agency terminates its participation in the Data Sharing Option, Licensee will no longer

have access to the Shared Databases of such Agency or to any information generated from the Shared Databases associated with previously run searches and any resulting matches.

5. **Licensee Responsibilities.** Licensee shall be solely responsible for its use of the Shared Databases. Licensee represents and warrants that (a) it will use the Shared Databases solely in conjunction with its use of the IDentify Application in accordance with the terms of this Addendum, and (b) it will use the Shared Databases (including all data, content, materials, information and results contained in and/or generated from any of the foregoing) in compliance with all applicable laws, statutes, ordinances, rules, regulations, consent decrees, and/or requirements of any regulatory authority. Licensee shall defend, indemnify and hold harmless Veritone and its affiliates and licensors, and their respective members, officers, directors, employees, and agents, from and against any liability, losses, damages, judgments, costs and expenses, including litigation costs and reasonable attorneys' fees, arising out of or resulting from Licensee's use of the Shared Databases or Licensee's breach of any of its representations, warranties or obligations set forth in this Addendum.
6. **Authority.** The person executing this Addendum on behalf of each party represents and warrants that he or she has full authority to execute the same on behalf of such party, and that no other actions or approvals are required for such party to enter into this Addendum and perform its obligations hereunder.

IN WITNESS WHEREOF, the parties have caused this Addendum to be executed by their duly authorized representatives as of the date first above written.

VERITONE, INC.

Signature:

Name:

Title:

IRVINE POLICE DEPARTMENT

Signature:

Name:

Title:



PILOT EVALUATION LICENSE AGREEMENT

This Pilot Evaluation License Agreement ("Agreement") is entered into as of the date of the last signature below ("Effective Date") by and between Veritone, Inc. (for itself and/or its subsidiaries), having a principal office located at 575 Anton Boulevard, Suite 100, Costa Mesa, CA 92626 ("Veritone") and the entity listed under Licensee Information below ("Licensee"), with respect to license(s) to Veritone's aiWARE Platform and related Services.

Table with sections: LICENSEE INFORMATION (Agency Name, Address, Contact Name, Phone, Email), LICENSE AND SERVICES DETAILS (Term, Start Date, End Date, No. of Users, License Fees, Services, Cognitive Processing), and TERMS AND CONDITIONS.

- 1. Master License Terms and Conditions. This Agreement and Licensee's access to and use of the Platform and Services shall be governed by the Veritone Master License Terms and Conditions attached hereto as Attachment A and incorporated herein by reference (the "Terms and Conditions").
2. Identify Application and Cognitive Processing. During the Term, Veritone will provide Licensee with access to the IDentify Application and the cognitive processing specified above for content uploaded to the Platform by Licensee through the IDentify Application, for purposes of evaluation of the Platform and Services by Licensee.
3. Limitations. Licensee acknowledges that the IDentify Application is intended to be used by Licensee only as a tool to support review of digital evidence in connection with its investigations, and the IDentify Application and the results generated therefrom should not be considered or relied upon as a substitute for Licensee's customary investigative procedures, protocols and/or requirements.
4. Authority. The person executing this Agreement on behalf of each party represents and warrants that he or she has full authority to execute the same on behalf of such party, and that no other actions or approvals are required for such party to enter into this Agreement and perform its obligations hereunder.

Table with 2 columns: VERITONE, INC. and LICENSEE. Rows include Signature, Name, Title, and Date for both parties.

ATTACHMENT A

**VERITONE, INC. MASTER LICENSE TERMS AND CONDITIONS
(PS-Rev 20180907)**

(Attached)

VERITONE, INC.

MASTER LICENSE TERMS AND CONDITIONS

These Master License Terms and Conditions (“Terms and Conditions”) apply to any License Agreement (as defined below) between Veritone, Inc. (or one of its subsidiaries) (“Veritone”) and a licensee (“Licensee”).

- 1. License Agreement; Controlling Terms.** For purposes hereof, “License Agreement” shall mean the written license agreement, or the order form, subscription form, statement of work or other document, including any addenda or exhibits thereto, accepted by Veritone in writing, that evidences the purchase of a license from Veritone by the Licensee (either directly or through an authorized reseller of Veritone) to access and use the Veritone aiWARE Platform (the “Platform”) and associated Services (as defined below). The Platform is an artificial intelligence operating system that delivers near real-time media processing and analytics, enabling users to process, index, organize, manage, search, analyze and share audio, video and other data through a suite of applications and other services (collectively, the “Services”). The specific Services, content, fees and payment terms, number of authorized users, and the term of license shall be as set forth in the License Agreement. The License Agreement may also contain other license-specific terms and conditions. The License Agreement and these Terms and Conditions are collectively referred to herein as this “Agreement.” In the event of any conflict or inconsistency among the terms and conditions set forth in the License Agreement and in these Terms and Conditions, the rights and obligations of the parties shall be interpreted based on the following order of priority: (1) the License Agreement and (2) these Terms and Conditions. This Agreement constitutes the complete and exclusive agreement between the parties with respect to the Platform and Services, superseding and replacing any and all prior agreements, communications, and understandings, both written and oral, regarding such subject matter, and no additional or different provision contained in any purchase order form, order acknowledgment form, invoice or similar form of either party will be effective.
- 2. License, Reservation of Rights, Restrictions.**
 - 2.1. License.** Veritone hereby grants to Licensee, during the Term (as defined in Section 7 below), a non-transferable, non-sublicensable, non-exclusive, revocable license to access and use the Platform and Services, subject to the terms and conditions set forth in this Agreement (the “License”). Licensee agrees to use the Platform and Services only for its internal business purposes in accordance with the terms of this Agreement. For the avoidance of doubt, the Platform and Services and its content may not be displayed publicly; provided that, subject to the provisions of Section 2.4 (Restrictions) and Section 11 (Indemnification) of this Agreement, Licensee may post, publish or otherwise share its owned or licensed content via the Platform for which sharing capabilities are enabled during the Term in accordance with the terms of this Agreement.
 - 2.2. Reservation of Rights.** The Platform and Services are licensed by Veritone to Licensee, and not sold. Licensee acquires only the right to use the Platform and Services in accordance with this Agreement and does not acquire any rights of ownership. Nothing herein shall be construed to transfer any rights, title or ownership of any Veritone or Veritone-licensed software, technology, materials, information or Intellectual Property Rights to Licensee. All right, title and interest (including all Intellectual Property Rights) in and to the Platform and Services shall at all times remain the sole and exclusive property of Veritone and/or its respective licensors and all use thereof shall inure to the benefit of Veritone and/or its respective licensors. Except as expressly set forth in this Agreement, no right or license, express or implied, is granted to Licensee or any third party by estoppel, implication, exhaustion or other doctrine of law, equity or otherwise with respect to any product, service, software, technology, materials, information or Intellectual Property Rights of Veritone or its affiliates or licensors. “**Intellectual Property Rights**” means all forms of proprietary rights, titles, interests, and ownership including patents, patent rights, copyrights, trademarks, trade dresses, trade secrets, know-how, mask works, *droit moral* (moral rights), publicity rights and all similar rights of every type that may exist now or in the future in any jurisdiction, including without limitation all applications and registrations therefore and rights to apply for any of the foregoing.
 - 2.3. Third Party Licenses.** Certain software components of the Platform and Services are supplied pursuant to license agreements from third parties, and Licensee agrees that Licensee’s use of the Platform and Services shall be subject to the provisions of such third party license agreements.
 - 2.4. Restrictions.**
 - 2.4.1. License Restrictions.** Licensee agrees to use the Platform and Services only for lawful purposes and only as expressly authorized under this Agreement. Without limiting the generality of the foregoing, except as expressly authorized hereunder, Licensee agrees that it shall not, directly or indirectly: (i) license, sublicense, sell, resell, rent, lease, transfer, assign, distribute, display or otherwise make the Platform or Services, in whole or in part, including any content or data derived therefrom that is not directly owned by Licensee or for which Licensee has

all necessary rights, available to any third party, or use the Platform or Services to provide services to any third party; (ii) reverse engineer, decompile, disassemble, modify, translate, reconstruct, omit, distort, obscure, copy or create derivative works of all or any portion of the Platform, Services, any underlying software, or any other Veritone Property (as defined below), or otherwise attempt to access the source code of the Platform or Services; (iii) incorporate any portion of the Platform or Services into Licensee's own programs or compile any portion of them in combination with Licensee's own programs; (iv) store or otherwise capture to physical media, or enable a third party to store or capture, the Platform or Services or any portion thereof; (v) permit any persons, other than Licensee's authorized users for which Licensee has procured User IDs pursuant to the License Agreement, to access and use the Platform or Services; (vi) upload or transmit through the Platform or Services any material, content, media or data (collectively, "Licensee Content") with respect to which Licensee does not either own all right, title and interest or have the appropriate license(s) for lawful use, or otherwise violate or infringe upon the intellectual property rights of any third party in Licensee's use of the Platform or Services, including the use or distribution of any data derived from the Platform or Services; or (vii) violate any laws, rules or regulations in connection with its use of the Platform or Services, including any data or content contained in, transmitted through or derived therefrom.

2.4.2. Prohibited Acts. Licensee acknowledges and agrees that Licensee is prohibited from doing any act that may have the effect of undermining the integrity of the Platform, Services, any related computer systems, infrastructure or environment, or the methods by which Veritone provides Services to users. Without limiting the generality of the foregoing, Licensee agrees that it shall not, directly or indirectly: (i) defeat, circumvent or modify any authentication technology or other security measures, controls, limitations, or content or functionality filters contained in or associated with the Platform or Services, or otherwise attempt to access any aspect of the Platform or Services that Licensee has not been granted authorization to access under the License Agreement; (ii) deploy or facilitate the use or deployment of any script, routine, robot, spider, scraper or any other automated means, method or device with respect to Licensee's access and use of the Platform and Services for any purpose, including to access, view, select, or copy in whole or in part, any content, program, functionality of the Platform or Services, or any other proprietary information or trade secret of Veritone that is made available through the Platform or Services; (iii) deploy or facilitate the use or deployment of any program, system, means, method or device, for any purpose that places an unreasonable, unnecessary or excessive demand or load on the Platform, Services, or related hardware and connections, or prohibits, denies or delays access to Services by other users or otherwise threatens the continuous services of Veritone's ISPs, suppliers and vendors; (iv) introduce into the Platform or Services any program, executable file or routine (such as a worm, Trojan horse, cancel-bot, time bomb or virus) irrespective of whether any such program or routine results in detrimental harm to the Platform, Services, or any underlying systems or programs; (v) remove any proprietary notices, labels or marks from the Platform or Services; (vi) establish any direct or deep link or other connection to any specific page or location within the Platform or Services, other than the Platform log-in page; (vii) use or attempt to use another user's account without authorization, or interfere with another user's access to the Platform or Services; or (viii) access or use the Platform or Services to design, develop, build, market or support a competitive product or service.

3. Access and Use. Veritone will enable Licensee to access and use the Platform for the duration of the Term, subject to any early termination of this Agreement in accordance with the terms hereof. Access to the Platform will be through unique log-in credentials assigned to Licensee by Veritone (each, a "User ID"). Licensee shall be given that number of User IDs as specified in the License Agreement. Licensee will provide accurate and complete information in registering its authorized users for account access. Licensee acknowledges and agrees that the log-in credentials assigned hereunder are Confidential Information and may only be used by Licensee and its authorized users to access the Platform in accordance with the terms of this Agreement, and that Licensee will not publish, share, or otherwise enable any third party, directly or indirectly, to access the Platform for any purpose. Licensee further agrees that Licensee is responsible for its and its authorized users' use of the Platform, including use via the User IDs, and for any consequences thereof. Licensee agrees to immediately notify Veritone of any unauthorized or improper use of any log-in credentials of Licensee. All of the rights, obligations, restrictions, representations and warranties related to Licensee's access and use of the Platform under this Agreement shall apply to Licensee and all of Licensee's employees, contractors, consultants, representatives and agents (collectively, "Representatives"). Licensee shall be responsible for all acts and omissions of its Representatives in the performance of this Agreement and for any breach of this Agreement by any of its Representatives.

4. Intellectual Property.

4.1. Veritone Property. As between Veritone and Licensee, Veritone and/or its respective licensors retain all right, title and interest (including Intellectual Property Rights) in and to the Platform and Services, including, but not limited to any

elements, components, content, technology, software, code, documentation, derivative works, revisions, enhancements, modifications, condensations and/or compilations of or relating to the Platform and Services, and any trademarks, brand identifiers, materials and information, which are created, authored, developed, conceived and/or reduced to practice by Veritone and/or its respective licensors, including in connection with Veritone's provision of the Platform and Services to Licensee under this Agreement ("**Veritone Property**").

4.2. Licensee Property. As between Licensee and Veritone, Licensee retains all right, title and interest (including Intellectual Property Rights) in and to the Licensee Content, and any software, technology, trademarks, brand identifiers, materials and information which are independently created, authored, developed, conceived or reduced to practice by Licensee.

5. Licensee Content.

5.1. Content Ownership. Licensee represents and warrants that (i) Licensee and/or its licensors own all right, title and interest in and to all Licensee Content uploaded to or transmitted through the Platform or Services, or otherwise have all rights in such Licensee Content as necessary to use the same in connection with Licensee's use of the Platform and Services, (ii) such Licensee Content does not and will not misappropriate or infringe upon any third party's Intellectual Property Rights, or violate any other rights of any third party, and (iii) Licensee has all rights in such Licensee Content necessary to grant the rights contemplated by this Agreement.

5.2. License to Content. Unless otherwise specified in the License Agreement, Licensee hereby grants to Veritone a non-exclusive, royalty-free, worldwide license (i) to use and display all Licensee Content that Licensee provides to Veritone or that are otherwise uploaded to or captured by the Platform through Licensee's use of the Platform and Services to provide the Services and perform its obligations under this Agreement, directly or through its third party service providers, and (ii) to share such Licensee Content with Veritone's third party service providers solely as required for Veritone's provision of the Platform and Services to Licensee.

5.3. Data Security and Destruction. Veritone will maintain and use adequate administrative, physical, and technical safeguards for protection of the security, confidentiality and integrity of all Licensee Content uploaded to or transmitted through the Platform or Services. Licensee Content shall be used and stored by Veritone solely to the extent required to provide the Services and perform its obligations under this Agreement or as otherwise expressly provided in the License Agreement, and Veritone shall not use or store the Licensee Content for any other purpose whatsoever. Upon termination of this Agreement or upon the written request of Licensee at any time, Veritone shall ensure the secure deletion and destruction of all Licensee Content.

6. Feedback. During the Term, Licensee may provide Veritone with such written evaluations, comments and/or suggestions (collectively, "**Feedback**") regarding the Platform or Services. Licensee acknowledges and agrees that any Feedback provided to Veritone by Licensee hereunder shall be deemed to be Veritone Property and Licensee hereby assigns all right, title and interest in and to such Feedback to Veritone and acknowledges that Veritone will be entitled to, without limitation, implement and exploit any such Feedback in any manner without any restriction or obligation. Notwithstanding the foregoing, Licensee acknowledges that Veritone is not obligated to act on any such Feedback.

7. Term and Termination.

7.1. Term. The term of this Agreement and the License shall be as set forth in the License Agreement (the "**Term**").

7.2. Termination. In addition to any termination rights expressly provided in the License Agreement, this Agreement may be terminated by either party if the other party (i) materially breaches any provision of this Agreement which remains uncured for a period of fourteen (14) days from the date of written notice of such breach; or (ii) makes an assignment for the benefit of its creditors, is declared insolvent, or has a receiver or trustee in bankruptcy appointed to take charge of all or part of such party's property.

7.3. Effect of Termination. If at any time this Agreement is terminated, or upon expiration of the Term, the License and all other rights granted to Licensee herein shall automatically terminate and Licensee shall immediately cease using the Platform and Services.

7.4. Survival. The provisions of Sections 2.2 (Reservation of Rights), 4 (Intellectual Property), 6 (Feedback), 7.3 (Effect of Termination), 8.1 (Fees and Payments), 8.2 (Taxes), 10 (Confidentiality), 11 (Indemnification), 12.2 and 12.3 (Warranty and Disclaimers), 13 (Limitation of Liability), 14 (Miscellaneous) hereof and the payment terms of License Agreement, as applicable, shall survive the expiration or any early termination of this Agreement for any reason.

8. Fees, Charges and Payments.

8.1. Fees and Payments. In consideration for the License and Licensee's access and use of the Platform and Services, Licensee shall pay the license fees, and any applicable additional fees, as set forth in the License Agreement (collectively, the "Fees"). All Fees and other amounts due under this Agreement are payable in U.S. dollars.

8.2. Taxes. All Fees and any other amounts due hereunder are exclusive of taxes and similar assessments which may be imposed on the delivery of the Platform and Services and any other transactions contemplated hereby. Licensee shall be solely responsible for the payment of any and all sales, use, value added, excise, import, or other similar taxes or payments in lieu thereof, including interest and penalties thereon, imposed by any authority, government or governmental agency arising out of or in connection with amounts due hereunder (other than those levied on Veritone's income), and Licensee shall make such payments, and timely file any return or information required by treaty, law, rule or regulation. Upon request, Licensee shall provide Veritone with documentation evidencing such payments. If Veritone is required to pay any such taxes, duties or fees, Licensee shall reimburse Veritone immediately upon receipt of Veritone's invoice thereof.

8.3. Suspension of Platform Access. In addition to Veritone's termination rights set forth herein and without prejudice to any other rights of Veritone at law or in equity, Veritone may suspend its performance under this Agreement and any other agreement with Licensee and Licensee's access to the Platform if Licensee fails to comply with any part of its payment obligations set forth herein. Such suspension of service shall not suspend or otherwise affect Licensee's payment obligations set forth herein.

9. Changes to Platform, Service and Fees. Veritone may, from time to time, in its sole discretion, make changes to the Platform and Services, or a portion thereof including, without limitation, formats, content, reports, functionality, and/or techniques ("Service Change"). In the event of a Service Change, Veritone may, adjust the Fees for the Platform and Services ("Fee Change") in writing. Such Fee Change shall become effective on the date stated in Veritone's notice to Licensee unless, within fifteen (15) days after a Fee Change notice that would result in an increase in the Fees, Licensee notifies Veritone in writing of its refusal to accept the Fee Change, in which event the applicable License to Licensee shall terminate as of the effective date of the change; provided, however, that if the Fee Change is an increase in the Fees, Veritone may, in its sole discretion, elect to rescind the Fee Change, in which case the Platform and Services, as changed, shall continue as provided herein.

10. Confidentiality.

10.1. Confidential Information. Each party (a receiving party) acknowledges and agrees that during the Term and in the course of using the Platform and Services and performing its duties under this Agreement, it may obtain information relating to the other party (a disclosing party), its and/or its customers', vendors', or third party service providers' business or technologies, which is of a confidential and proprietary nature ("**Confidential Information**"). Such Confidential Information may include, but is not limited to, trade secrets, know-how, inventions, techniques, processes, software, algorithms, programs, schematics, data, technology roadmap, sales and marketing plans, and any other information which the receiving party knows or has reason to know is, or which by its nature would reasonably be considered to be, confidential, proprietary or trade secret information of the other party. Without limiting the foregoing, Confidential Information of Veritone shall include the Platform, Services and all associated software and documentation, as well as Feedback or any results of the evaluation or testing of the Platform or Services. The receiving party shall at all times, both during the Term and for a period of three (3) years after its termination (or, in the case of the Platform, Services and any associated software or trade secrets, in perpetuity), keep in trust and confidence all Confidential Information of the disclosing party, and shall not (i) use such Confidential Information other than as expressly authorized under this Agreement or as required for the receiving party to perform its obligations under this Agreement, or (ii) disclose any Confidential Information of the disclosing party to third parties (other than to Veritone's third party service providers in connection with the performance of its obligations under this Agreement), without the disclosing party's prior written consent. The receiving party further agrees to immediately return to the disclosing party or destroy all Confidential Information (including all copies, extracts and summaries thereof) in the receiving party's possession, custody, or control upon the expiration or any termination of this Agreement. The obligations of confidentiality shall not apply to information which (a) has entered the public domain except where such entry is the result of the receiving party's breach of this Agreement; (b) prior to disclosure hereunder, was already in the receiving party's possession and not subject to any confidentiality obligations, as demonstrated by written evidence; (c) subsequent to disclosure hereunder is obtained by the receiving party on a non-confidential basis from a third party who has the right to disclose such information to the receiving party; or (d) has been independently developed by the receiving party without use of or reference to the disclosing party's Confidential Information, as demonstrated by written evidence.

10.2. Permitted Disclosures. The receiving party may make disclosures (i) as required by applicable law or the rules of a stock exchange on which such party's shares are then traded; or (ii) as compelled by court order issued by a court of competent

jurisdiction provided that the receiving party subject to such court order (a) provides the disclosing party with prompt written notice of any such compelled disclosure, (b) uses diligent reasonable efforts to limit disclosure, (c) uses commercially reasonable efforts to obtain confidential treatment or a protective order in connection with the information subject to such compelled disclosure, and (d) allows the disclosing party to participate in any such proceeding.

11. Indemnification.

11.1. Licensee Indemnification of Veritone. Licensee will defend, indemnify and hold harmless Veritone and its subsidiaries, affiliates, successors, assigns, licensors, and their respective members, officers, directors, employees, licensors, agents, from and against any liability or expense, including, without limitation, any expenses, losses, damages, judgments, litigation costs and reasonable attorneys' fees, that Veritone may incur as a result of any claim, suit or proceeding brought against Veritone by any third party arising or resulting from (a) Licensee's breach of any representation, warranty, covenant or obligation contained in this Agreement; or (b) Licensee's use of the Platform or Services (including uploading, using, publishing, posting or otherwise sharing of Licensee's Content or any other data or content derived from the Platform or Services) in any manner that violates this Agreement or any laws, rules, regulations or third party terms and conditions, or that misappropriates or infringes the rights (including Intellectual Property Rights) of any third party; *provided that* Veritone gives Licensee prompt notice of any such claims, cooperates with Licensee in responding to such claims, and permits Licensee to control the defense or settlement of such claims, subject to Veritone's right to (i) conduct the defense of such claims at Veritone's expense, or participate in the defense of such claims with its own counsel at its own expense, and (ii) approve any settlement that binds or purports to bind Veritone.

11.2. Veritone Indemnification of Licensee. Veritone will defend, indemnify and hold harmless Licensee and its subsidiaries, affiliates, successors, assigns, licensors, and their respective members, officers, directors, employees, licensors, agents, from and against any liability or expense, including without limitation, any expenses, losses, damages, judgments, litigation costs and reasonable attorneys' fees that Licensee may incur as a result of any claim, suit or proceeding brought against Licensee by any third party arising or resulting from (a) Veritone's breach of any representation, warranty, covenant or obligation contained in this Agreement; or (b) any allegation that the Platform or Services, or any part thereof, misappropriates or infringes upon any third party's Intellectual Property Rights, except to the extent such claims arise from Licensee's negligence, misconduct or violation of any terms of this Agreement; *provided that* Licensee gives Veritone prompt notice of any such claims, cooperates with Veritone in responding to such claims, and permits Veritone to control the defense or settlement of such claims, subject to Licensee's right to (i) conduct the defense of such claims at Licensee's expense, or participate in the defense of such claims with its own counsel at its own expense, and (ii) approve any settlement that binds or purports to bind Licensee. If the Platform, in whole in part, becomes or, in Veritone's opinion is likely to become, the subject of an infringement claim or action, Veritone may, at its option: (x) procure, at no cost to Licensee, the right for Licensee to continue using the Platform; (y) replace or modify the Platform to render the Platform non-infringing, provided there is no material loss of functionality; or (z) if, in Veritone's reasonable opinion, neither (x) nor (y) above is commercially feasible, terminate this Agreement and refund any prepaid amounts for unused Services during the terminated portion of the Term. The foregoing states Veritone's sole obligation and Licensee's exclusive remedy in the event any such infringement claim or action is commenced or is likely to be commenced.

12. Warranties and Disclaimers.

12.1. Mutual Warranties. Each party represents and warrants to the other that: (i) it is duly organized and validly existing under the laws of the jurisdiction of its incorporation or formation, and has full power, rights and authority to enter into this Agreement and carry out its obligations hereunder; (ii) the person executing this Agreement is authorized to do so on its behalf; (iii) this Agreement is valid and legally binding upon it and (iv) the execution, delivery and performance thereof by such party does not conflict with any other agreement, instrument or understanding to which it is a party or by which it may be bound, nor would violate any applicable law or regulation.

12.2. Disclaimer. THE PLATFORM, SERVICES AND ANY OTHER VERITONE PRODUCTS AND SERVICES ARE PROVIDED ON AN "AS IS" AND "AS AVAILABLE" BASIS. EXCEPT AS EXPRESSLY PROVIDED IN THIS AGREEMENT, VERITONE MAKES NO WARRANTY, EXPRESS OR IMPLIED, WITH RESPECT TO THE PLATFORM AND SERVICES, INCLUDING, WITHOUT LIMITATION, ANY WARRANTY AS TO THE ACCURACY OF PROCESSING RESULTS, ANY WARRANTY OF MERCHANTABILITY, QUALITY OR FITNESS FOR A PARTICULAR PURPOSE, WARRANTIES ARISING FROM COURSE OF DEALING OR USAGE OF TRADE, AND WARRANTIES OF NON-INFRINGEMENT. VERITONE DOES NOT WARRANT THAT THE PLATFORM AND SERVICES ARE ERROR-FREE, WILL RUN UNINTERRUPTED, OR THAT ALL ERRORS CAN OR WILL BE CORRECTED. NO ADVICE OR INFORMATION, WHETHER ORAL OR WRITTEN, OBTAINED BY LICENSEE FROM VERITONE SHALL CREATE ANY SUCH WARRANTY.

12.3. LICENSEE ACKNOWLEDGES AND AGREES THAT THE INTERNET IS A PUBLIC NETWORK OVER WHICH VERITONE EXERTS NO CONTROL. VERITONE MAKES NO REPRESENTATIONS OR WARRANTIES WHATSOEVER, AND SHALL HAVE NO LIABILITY WHATSOEVER, WITH RESPECT TO THE ACCURACY, DEPENDABILITY, PRIVACY, SECURITY, AUTHENTICITY OR COMPLETENESS OF DATA TRANSMITTED OVER OR OBTAINED USING THE INTERNET OUTSIDE OF THOSE SYSTEMS AND NETWORKS CONTROLLED BY VERITONE, OR ANY INTRUSION, VIRUS, DISRUPTION, LOSS OF COMMUNICATION, LOSS OR CORRUPTION OF DATA, OR OTHER ERROR OR EVENT CAUSED OR PERMITTED BY OR INTRODUCED THROUGH LICENSEE'S OWN USE OF THE INTERNET. LICENSEE IS SOLELY RESPONSIBLE FOR IMPLEMENTING ADEQUATE FIREWALL, PASSWORD AND OTHER SECURITY MEASURES TO PROTECT ITS SYSTEMS, DATA AND APPLICATIONS FROM UNWANTED INTRUSION, WHETHER OVER THE INTERNET OR BY OTHER MEANS.

13. Limitation of Liability.

13.1. EXCEPT FOR (A) BREACHES OF EACH PARTY'S OBLIGATIONS UNDER SECTION 10 (CONFIDENTIALITY), AND (B) AMOUNTS FINALLY AWARDED OR SETTLED IN A THIRD PARTY CLAIM FOR WHICH A PARTY IS RESPONSIBLE UNDER SECTION 11 (INDEMNIFICATION), NEITHER PARTY, INCLUDING ITS OFFICERS, DIRECTORS, EMPLOYEES, REPRESENTATIVES AND AFFILIATES, SHALL BE LIABLE FOR ANY INDIRECT, INCIDENTAL, SPECIAL, CONSEQUENTIAL, OR PUNITIVE DAMAGES, INCLUDING WITHOUT LIMITATION, LOST DATA OR LOST PROFITS, OR COSTS OF PROCURING SUBSTITUTE GOODS OR SERVICES, HOWEVER ARISING, EVEN IF IT HAS BEEN ADVISED OF THE POSSIBILITY OF SUCH DAMAGES.

13.2. EXCEPT WITH RESPECT TO EACH PARTY'S CONFIDENTIALITY AND INDEMNIFICATION OBLIGATIONS HEREUNDER, NEITHER PARTY'S LIABILITY FOR DAMAGES ARISING OUT OF, RELATING TO OR IN ANY WAY CONNECTED WITH THIS AGREEMENT SHALL EXCEED THE TOTAL FEES PAID BY LICENSEE TO VERITONE UNDER THIS AGREEMENT.

14. MISCELLANEOUS

14.1. No Assignment. Neither party may assign any of its rights or obligations under this Agreement without the prior written consent of the other party, except that either party may assign its rights and obligations under this Agreement without the consent of the other party to an affiliate directly or indirectly controlling, controlled by, or under direct or indirect common control with such party or in connection with any merger (by operation of law or otherwise), consolidation, reorganization, change in control or sale of all or substantially all of its assets related to this Agreement or similar transaction. This Agreement inures to the benefit of and shall be binding on the parties' permitted assignees, transferees and successors.

14.2. Severability. If any provision of this Agreement is found by a court of competent jurisdiction to be invalid, the parties nevertheless agree that the court should endeavor to give effect to the parties' intentions as reflected in such provision, and the other provisions of this Agreement remain in full force and effect.

14.3. No Waiver. The failure of either party to exercise or enforce any right or provision of this Agreement shall not constitute a waiver of such right or provision.

14.4. Controlling Law. This Agreement shall be governed by and construed in accordance with the laws of the State of California (other than the conflict of law rules) and subject to the sole jurisdiction of the courts sitting in Orange County, California. Notwithstanding the foregoing, nothing in this Section 14.4 shall be deemed to limit the parties' rights to seek injunctive relief in any other court of law of competent jurisdiction.

14.5. Independent Contractors. This Agreement does not create any relationship other than Veritone as an independent contractor performing services covered by this Agreement and Licensee as the party contracting with Veritone for those services. No party is a partner or a legal representative of the other for any purpose whatsoever, nor is any party authorized to make any contract, agreement or warranty on behalf of any other party. Under no circumstance shall one party's employees be construed to be employees of the other party.

14.6. Publicity. Except as required or compelled by applicable law, the rules of any stock exchange, or a court order issued by a court of competent jurisdiction, neither party will make any public statement regarding, or disclose, advertise or publish the terms and conditions of this Agreement without the prior written consent of the other party; provided, however, that Veritone may reference Licensee on Veritone's website, other marketing materials, investor relations materials, and as a customer in Veritone's SEC filings.

14.7. Notices. All notices to either party shall be in writing and delivered by hand or by certified mail or overnight delivery service to the address set forth by Licensee and/or Veritone in the License Agreement, or to such other address as either party shall provide by notice to the other party. Alternatively, the parties may, at their election, utilize email as the method of delivery of any such notice to be provided hereunder. Any such notices sent by email shall be delivered to the email addresses set forth in the License Agreement, or such other email address as designed by a party during the Term. Notices shall be deemed effective when delivered to the applicable address, unless any such notice is sent by

email, in which event, notice shall be deemed effective upon confirmation of delivery by a “read receipt” or other such notice generated by the applicable email system, but in any event, by reply of the recipient of such notice.

- 14.8. Electronic Communication.** In connection with its use of the Platform and Services, Licensee consents to receiving communications from Veritone electronically. Veritone will communicate with Licensee by e-mail or by posting notices on the Platform or through any Services. Licensee agrees that all notices, disclosures and other communications that Veritone provides to Licensee electronically satisfy any legal requirement that such communications be in writing.
- 14.9. Force Majeure.** Except for the obligation to make payments of any Fees or any other amounts due hereunder, neither party will be liable for any failure or delay in its performance under the Agreement due to any cause beyond such party’s control including acts of war, terrorism, acts of God, embargo, riot, sabotage, labor shortage or dispute, governmental act, or failure of the Internet, or any component comprising or operating the network infrastructure thereof (each, a “**Force Majeure Event**”), provided that the delayed party: (i) gives the other party prompt notice of such cause, and (ii) uses its reasonable commercial efforts to promptly correct such failure or delay in performance. If Veritone is unable to provide Service(s) for a period of sixty (60) consecutive days as a result of a continuing Force Majeure Event, either party may elect to terminate this Agreement.
- 14.10. Construction.** This Agreement shall be fairly interpreted and construed in accordance with its terms and without strict interpretation or construction in favor of or against either party. Each party has had the opportunity to consult with counsel in the negotiation of this Agreement.
- 14.11. Counterparts.** This Agreement may be executed in one or more counterparts (including fax or email) each of which shall be deemed an original but all of which taken together shall be deemed one and the same instrument.
- 14.12. Headings.** Unless otherwise expressly stated in this Agreement, the words “herein,” “hereof,” “hereto,” and “hereunder” and other words of similar import refer to this Agreement as a whole and not to any particular section, subsection, or other subdivision. The words “include” and “including” shall not be construed or interpreted as terms of limitation. The words “day,” “month,” and “year” mean, respectively, calendar day, calendar month, and calendar year. Section headings are for reference purposes only, and should not be used in the interpretation hereof.
- 14.13. Amendment.** No addendum, waiver, consent, modification, amendment or change of the terms of this Agreement shall bind either party unless in a writing that references this Agreement and is signed by duly authorized representatives of Licensee and Veritone.
- 14.14. Attorney’s Fees.** If any action arises under this Agreement, including, without limitation the interpretation or enforcement of any term of this Agreement, the prevailing party in any such action shall be entitled to recover its reasonable attorney’s fees and related costs.

From: Mark Anderson
Sent: Tuesday, February 19, 2019 12:22 PM PST
To: Noelle Smiley
Subject: RE: Veritone pilot agreement
Attachments: image003.png, image004.png

Roger that. Thank you

From: Noelle Smiley
Sent: Tuesday, February 19, 2019 10:54 AM
To: Mark Anderson <manderson@cityofirvine.org>
Subject: FW: Veritone pilot agreement

Cindy will get this to their admin secretaries for fast distribution. Or so I'm told....

From: Mark Anderson
Sent: Tuesday, February 19, 2019 7:25 AM
To: Noelle Smiley <nsmiley@cityofirvine.org>
Subject: FW: Veritone pilot agreement

Commander,

Attached is the revised contract with Veritone reference the trial period T&E for the facial recognition software. Would you like me to send it to the City Attorney's Office for review?

Thanks

Mark

From: William Hillyard
Sent: Friday, February 15, 2019 1:48 PM
To: Mark Anderson <manderson@cityofirvine.org>
Subject: FW: Veritone pilot agreement

LT,

Here is the revised License Agreement for your review. As we discussed, they have changed the wording, and in fact changed the title of the document all together. The document is now a "Pilot Evaluation License Agreement" with an end date of May 30, 2019. The license fee is "Waived for pilot evaluation" and there is no mention anywhere in any of the new documentation of a cost for an ongoing license for the software if we decided to move forward with making a purchase. As we've talked about, not having any idea of a pricing structure is not ideal, but I don't believe even at this point that Veritone themselves have any clue what to charge for an annual license for this software. The agreement we would be signing here is the same agreement Station 18 and Anaheim PD are operating under.

Please let me know if you have any question regarding the new documents.

Thank you,



William Hillyard | Detective | Irvine Police Department
949-724-7085 | 1 Civic Center Plaza, Irvine, CA 92606
whillyard@cityofirvine.org | cityofirvine.org

From: Tom Avery <tavery@veritone.com>
Sent: Friday, February 15, 2019 6:17 AM
To: William Hillyard <whillyard@cityofirvine.org>
Subject: Re: Veritone pilot agreement

Bill,

The updated pilot agreement is attached for your departments review. Let me know if you have any questions and have a good weekend.

Tom

From: William Hillyard <whillyard@cityofirvine.org>
Date: Thursday, February 14, 2019 at 12:27 PM
To: Tom Avery <tavery@veritone.com>
Subject: Re: Veritone pilot agreement

Hi Tom. Just checking in on the status of the revised quote?

Hope you're having a good/dry day.

Sent from my iPhone

On Feb 5, 2019, at 2:37 PM, Tom Avery <tavery@veritone.com> wrote:

Copy.

On Tue, Feb 5, 2019, 14:36 William Hillyard <whillyard@cityofirvine.org> wrote:

I just tried to call your cell. Measure S
[REDACTED] I'll probably be there for at least an hour.

Sent from my iPhone

On Feb 5, 2019, at 2:19 PM, Tom Avery <tavery@veritone.com> wrote:

I'll be in route to the Starbucks in about 10. Driving time from Irvine.

On Tue, Feb 5, 2019, 14:15 William Hillyard <whillyard@cityofirvine.org> wrote:

I'm around today. [REDACTED]

Investigation [REDACTED]

[REDACTED]. If that doesn't work I'll be in tomorrow at 10am. Feel free to call me at [REDACTED] Privacy [REDACTED] anytime. I'd like to try and get an answer to the LT by late today or tomorrow AM because they have the command staff meeting tomorrow where they probably want to present the agreement to the Chief.

Thanks,



William Hillyard | Detective | Irvine Police Department
949-724-7085 | 1 Civic Center Plaza, Irvine, CA 92606
whillyard@cityofirvine.org | cityofirvine.org

From: Tom Avery <tavery@veritone.com>
Sent: Tuesday, February 05, 2019 1:46 PM
To: William Hillyard <whillyard@cityofirvine.org>
Subject: Re: FW: Veritone pilot agreement

This was news to me as well. I stopped by HQ but you must be out on assignment. Let me know when you have some time to talk and I'll drop by.

Tom

On Tue, Feb 5, 2019, 12:52 William Hillyard <whillyard@cityofirvine.org> wrote:

Tom,

Can you please see the question below from Lt. Anderson. In the agreement it states the waived fee is \$15,000 per month, is that meant to be per year for the license fee we discussed in the meeting?

Thank you,



William Hillyard | Detective | Irvine Police Department
949-724-7085 | 1 Civic Center Plaza, Irvine, CA 92606
whillyard@cityofirvine.org | cityofirvine.org

From: Mark Anderson <manderson@cityofirvine.org>
Sent: Monday, February 04, 2019 2:18 PM
To: William Hillyard <whillyard@cityofirvine.org>
Subject: FW: Veritone pilot agreement

Hi Sir. In the License Agreement attached it talked about 15,000 per month, but it's waived? Just not clear what that means. Can you take and look at it and explain or reach out to Veritone and ask for an explanation. Thank you

From: William Hillyard
Sent: Thursday, January 31, 2019 8:13 AM
To: Mark Anderson <manderson@cityofirvine.org>
Subject: FW: Veritone pilot agreement

LT,

Attached are the documents for the Pilot Program agreement with Veritone that need Chief Hamel's signature. Here are some brief points regarding the agreements:

- Irvine PD can opt out of the data sharing portion of the software at any time. If we did opt out but continued to use the software the suspect photos would only be compared to our database of known offenders, and no other agencies would have access to our database of booking photos and known offenders.
- The free trial period for the Pilot Program is 90 days, not 60 as was discussed during our meeting with Veritone.
- The initial License Agreement states that we will have (5) user profiles. This is only for the term of the Pilot Program. If we go forward with purchasing the software we will have an unlimited number of user licenses.
- Section 5.3 of the Master License Terms and Conditions states that if we cancel our relationship with Veritone any data we have provided them is removed from their servers and deleted. There are several portions throughout the agreements which clearly spell out that the data provided by Irvine PD remains the property of Irvine PD and should we terminated our contract with them they have no rights to retain or continue to use any data we provided them.
- The data we are providing other agencies access to through Veritone is no different than the data we upload to Coplink on a daily basis.
- For the Pilot Program we will provide Veritone with an initial data dump of our current database of booking photos, if we go forward with purchasing the software Veritone can set up and automated upload of new booking photos so there is no additional workload for our personnel.

I spoke with Nick Rycroft Monday reference the IT portion of it and he stated when the agreement is signed by the Chief he would begin working on the data export as requested by Veritone.

Please let me know if can provide any additional information.

Thank you,

Bill Hillyard

Begin forwarded message:

From: Tom Avery <tavery@veritone.com>
Date: January 30, 2019 at 7:15:09 AM PST
To: William Hillyard <whillyard@cityofirvine.org>
Subject: Veritone pilot agreement

Bill,

Attached is the Veritone pilot agreement documents which also include the terms and conditions as well as the data sharing agreement. Let me know if you have any questions.

Thanks,
Tom

Tom Avery
Vice President Public Safety
Veritone Government
tavery@veritone.com

Privacy [REDACTED] cell

From: William Hillyard
Sent: Tuesday, February 19, 2019 5:24 PM PST
To: Mark Andreozzi
Subject: FW: ALPR Quote Irvine Police Department
Attachments: RU2-Fast-3370-VMS-Radar-Trailer.pdf, RU2 VMS Trailer Camera Box.jpg, RU2 VMS Trailer.jpg, 18504_2-VMS-ALPR-trailers.pdf, 18503_VMS-ALPR-trailer.pdf, image002.png

Sarge,

Sorry for the delay in getting this forwarded to you. Attached you will find the quote from Leonardo for their ALPR trailers. As you will see in the quote it comes out to just shy of \$100,000. The price includes (2) new trailers which we already have, so subtracting that from the quote it still comes out to approximately \$54,000 which is about \$10k higher than the quote we have from Vigilant. As I mentioned earlier today, Vigilant apparently also offers a package which includes ALPRs, Facial Recognition Software, and the access to their commercial data. I will arrange a meeting for us with the Vigilant rep as soon as he is available.

Please let me know if you have any questions.

Thank you,



William Hillyard | Detective | Irvine Police Department
949-724-7085 | 1 Civic Center Plaza, Irvine, CA 92606
whillyard@cityofirvine.org | cityofirvine.org

From: Desiree Holland <desiree.holland@leonardocompany-us.com>
Sent: Friday, February 08, 2019 1:20 PM
To: William Hillyard <whillyard@cityofirvine.org>
Subject: RE: ALPR Quote Irvine Police Department

Bill,

It was nice talking with you yesterday, thanks so much for reaching out.

I'm attaching RU2's brochure on the VMS trailer, take a look and let me know if this seems like a good fit. I'm also attaching several photos of the trailer with the ALPR box for concealment. If you have any questions about the trailer and its features, you can reach out to Ken Brown from RU2 Systems. His contact info is: kbrown@ru2systems.com 480-560-4385

I'm also attaching two separate quotes, one is for a single ALPR VMS trailer and the other is for two trailers. Keep in mind that the shipping service and the cost of data storage is an estimate for now. I quoted the cloud storage, but you can also host the data on an agency owned server. If you host the data in-house, there's an initial configuration fee of \$1250, but no recurring data storage costs.

Based on 365 days of data retention with an average of 10,000 reads per day, the estimated amount of space you'd need on a server for one trailer is 0.63 terabyte for image storage and 2.7 gigabytes for data storage. I am guessing that the average of 10,000 reads per day is going to be high for your trailer. Let me know if you want me to re-run the numbers using a different data retention period or estimated read numbers. If you have traffic counts for the area that you think you'll use the trailer most often, let me know and we can use those numbers!

Feel free to give me a call as you look over the information, I'm happy to go over it and answer questions.

Thanks and have a great weekend!

Desiree

Desiree Holland

Western Field Operations Manager
(Cell) Privacy

Technical Support: 866-967-4900

[Click here to open a support ticket](#)

THIS COMMUNICATION MAY CONTAIN CONFIDENTIAL AND/OR OTHERWISE PROPRIETARY MATERIAL and is thus for use only by the intended recipient. If you received this in error, please contact the sender and delete the e-mail and its attachments from all computers.

From: William Hillyard <whillyard@cityofirvine.org>
Sent: Thursday, February 7, 2019 12:29 PM
To: Desiree Holland <desiree.holland@leonardocompany-us.com>
Subject: ALPR Quote Irvine Police Department

Hi Desiree,

My name is Bill Hillyard and I am a Detective with the Irvine Police Department. Sergeant Andreozzi asked me to reach out to you regarding the purchase of two ALPR trailers for our department. We currently only have APLRs on a couple of our patrol units and we are interested in a solution that is mobile but can be placed in fixed positions throughout the city to address different crime trends as they arise. At your convenience could you please contact me at Privacy to discuss the particular information you might need to formulate a quote for us.

Thank you,



William Hillyard | Detective | Irvine Police Department
949-724-7085 | 1 Civic Center Plaza, Irvine, CA 92606
whillyard@cityofirvine.org | cityofirvine.org



Selex ES, Inc
 Elsag ALPR/ANPR Solutions
 4221 Tudor Lane
 Greensboro, NC 27410
 DUNS#: 198749777
 FED TAX ID: 980353098

QUOTE

Prepared By: Desiree Holland desiree.holland@leonardocompany-us.com
 Phone: 970-560-7990

Please include the quote number on your purchase orders and email them to orders@elsag.com for processing

Quote#: 18503
 Funding Source:
 Grant Details:
 Payment Method:
 Terms: Net 30 days from date of shipment. If installation is required then Net 30 days from the Installation Date. Elsag agrees not to ship equipment until an Installation Date is agreed upon by the Parties. All orders shipped FOB Greensboro
Make checks payable to Selex ES, Inc.

Quote Date: 2/8/2019
 Quote Expiry Date: 6/28/2019
 Requested Delivery Date: 8/1/2019
 Rate Sheet: Base Price

Contracts: No Contract Used

Comments: Elsag Speed/Radar/30" x 70" Variable Message Board Trailer with two LPR cameras and modem. Configured for connection to Cloud EOC, however customer may host data on agency owned server.

Please confirm sales tax rate

Bill To:	Irvine Police Department	Ship To:	Irvine Police Department
----------	--------------------------	----------	--------------------------

Product Qty	Product/Service	Unit Price	Amount
1	421752 - (421752) - LOW POWER RADAR TRAILER- 1 CAM	\$5,725.00	\$5,725.00
	(1) 421834 - M6 Trunkbox, 1-2 Cameras (1) 410917 - Garmin GPS Antenna (1) 410052 - Ethernet Cable Shielded 25 ft (1) 413083 - M6 Trunkbox Mounting Plate (1) 421805 - M6 Cam 25mm 740nm (1) 421812 - M6 Universal 1 Cam Mount (1) 412519-12 - 12ft Flat Transportable Camera Cable (1) 421805 - M6 Cam 25mm 740nm (1) 421812 - M6 Universal 1 Cam Mount (1) 412519-12 - 12ft Flat Transportable Camera Cable (1) 412713 - M6 Perm Power Cable, No Opus (1) 412995 - Packing Foam Insert (1) 510033-CSC - Car System Version 6.X - EOC Connected		
400	210012 - Shipping Service *ESTIMATE ONLY* Freight from Mesa, AZ - forklift required for delivery	\$4.00	\$1,600.00
1	413133 - Radar Speed Display Trailer RU2 VMS 3370 RADAR TRAILER	\$20,805.00	\$20,805.00

Product Qty	Product/Service	Unit Price	Amount
1	510160 - Data Acquisition Package	\$440.00	\$440.00
1	413030 - WIRELESS MODEM AIRLINK GX450 VERIZON ATT	\$790.00	\$790.00
1	530001-HOSTED-SETUP - Hosted EOC Setup (Up to 25 Users)	\$625.00	\$625.00
1	140012 - ELSAG Plate Hunter M6-2 <i>ALPR COMPONENTS</i>	\$11,500.00	\$11,500.00
1	210020 - Tech Dispatch	\$1,250.00	\$1,250.00
1	510322-5.X - EOC Operation Center License 5.X <i>one time software license per system</i>	\$1,275.00	\$1,275.00
1	530001-HOSTED-FIXED - Hosted EOC for Fixed Cameras Per TB required from the Capacity Planner for One Year – Minimum 1 TB	\$2,400.00	\$2,400.00
Subtotals	Goods & Services Sub-total (Pre-tax): Contract Items		\$0.00
	Goods & Services Sub-total (Pre-Tax): Non Contract Items		\$46,410.00
Upfront	Goods & Services Sub-total (Pre-tax):		\$46,410.00
Tax	Tax Rate: 7.750%		\$3,375.90
Total	Goods & Services Total:		\$49,785.90



Quote Offer Terms and Conditions

This Quote constitutes an Offer from Selex ES Inc. (Selex) to Customer, the terms of which become a binding contract between the Parties upon Customer's submitting a Purchase Order to Selex for the Products/Services and prices as identified herein.

Unless the Purchase Order is pursuant to a State or Federal cooperative purchasing agreement, or a separately executed Master Agreement, these Terms and Conditions supersede and replace any prior estimate, offer, quote, agreement, understanding or arrangement whether written or oral between the parties. If there is a discrepancy, please contact your account manager for correction.

These Terms and Conditions may not be changed or modified unless in writing by an authorized representative of Selex. Selex will not be bound by any terms of Buyer's purchase order unless expressly agreed to in writing by an authorized representative of Selex.

Shipment and Delivery. All orders shipped FOB Greensboro.

For purchases of Products that require installation: Unless otherwise agreed to by the Parties, Selex ES agrees not to ship Product until an Installation date is scheduled.

Title. Ownership of and Title to the Products shall transfer to the Customer upon shipment. All intellectual property rights, including without limitation, patents and /or the relevant applications, in or relating to the Products, to the Documentation and to the Software are and shall remain the property of Selex ES or its licensors. **Refer to the Selex Software License Agreement documentation provided with the shipment.**

Payment Terms. Selex shall invoice Customer no later than sixty (60) calendar days after shipment of the Products and/or performance of any Work or Services. Payment is due Net 30 days.

Taxes may not be reflected in this Quote. However, taxes may be added to the amount in the payment invoice(s) sent to Customer, unless Customer provides a certificate confirming tax exempt status.

Cancellation or Delay. Orders accepted by Selex are subject to cancellation by Customer only upon the express written consent of Selex. Upon such cancellation and consent, Selex shall cease all work pertaining to the Customer's order, and Customer shall pay Selex for all work and materials that have been committed to and/or identified in Customer's order plus a cancellation charge as prescribed by Selex.

Warranty. EXCEPT AS SET FORTH IN THIS AGREEMENT AND IN THE SELEX WARRANTY COVERAGE DOCUMENTATION, SELEX INC. MAKES NO OTHER WARRANTIES EXPRESS OR IMPLIED RELATING TO THE PRODUCTS OR SERVICES.

Applicable Law. The terms of this Quote, their interpretation, performance or any breach thereof, shall be construed in accordance with, and all questions with respect thereto shall be determined by, the laws of the state of North Carolina applicable to contracts entered into and wholly to be performed within said state. Any legal proceeding brought by either party pursuant to this Agreement shall be brought in a County or District Court located in Guilford County, North Carolina and the parties irrevocably consent to the jurisdiction of such courts.

FORCE MAJEURE. Either Party shall be excused for delays in delivery or in performance where such delay is directly due to act of God, acts of civil or military authority, fires, strikes, floods, epidemics, war, riot, or other similar causes beyond such Party's reasonable control. Such Party shall promptly give written notice to the other Party specifying the nature and probable extent of such delay. The Parties shall then immediately attempt to determine what fair and reasonable extension of schedules may be necessary. The parties agree to use their best efforts to mitigate the effects of the delay.

COMPLIANCE WITH LAWS. Customer shall comply with all federal, state, local, and territorial laws, including without limitation any export control, employment, tax, anti-corruption, anti-bribery, privacy and data protection, immigration and anti-discrimination laws, and shall indemnify Selex for any liability incurred by Selex as a result of breach of any such obligation.

EXPORT COMPLIANCE. This sale is subject to all laws, rules, regulations and public policies of the United States, particularly those relating to the exportation of goods from the United States and the transmission of technical data or other information outside the United States. By this purchase, Customer agrees to comply with all applicable U.S. laws and regulations which prohibit the export of technical data that originates in the U.S., or any product directly based on such data, without prior written authorization from appropriate U.S. agencies. Such compliance obligates Customer not to export Selex's confidential information or make it available to aliens or any unauthorized personnel, and to indemnify Selex for any liability incurred as a result of breach of such obligation.



Selex ES, Inc
 Elsag ALPR/ANPR Solutions
 4221 Tudor Lane
 Greensboro, NC 27410
 DUNS#: 198749777
 FED TAX ID: 980353098

QUOTE

Prepared By: Desiree Holland desiree.holland@leonardocompany-us.com
 Phone: 970-560-7990

Please include the quote number on your purchase orders and email them to orders@elsag.com for processing

Quote#: 18504
 Funding Source:
 Grant Details:
 Payment Method:
 Terms: Net 30 days from date of shipment. If installation is required then Net 30 days from the Installation Date. Elsag agrees not to ship equipment until an Installation Date is agreed upon by the Parties. All orders shipped FOB Greensboro
Make checks payable to Selex ES, Inc.

Quote Date: 2/8/2019
 Quote Expiry Date: 6/28/2019
 Requested Delivery Date: 8/1/2019
 Rate Sheet: Base Price

Contracts: No Contract Used

Comments: Elsag Speed/Radar/30" x 70" Variable Message Board Trailer with two LPR cameras and modem. Configured for connection to Cloud EOC, however customer may host data on agency owned server.

Please confirm sales tax rate

Bill To:	Irvine Police Department	Ship To:	Irvine Police Department
----------	--------------------------	----------	--------------------------

Product Qty	Product/Service	Unit Price	Amount
2	421752 - (421752) - LOW POWER RADAR TRAILER- 1 CAM	\$5,725.00	\$11,450.00
	(2) 421834 - M6 Trunkbox, 1-2 Cameras (2) 410917 - Garmin GPS Antenna (2) 410052 - Ethernet Cable Shielded 25 ft (2) 413083 - M6 Trunkbox Mounting Plate (2) 421805 - M6 Cam 25mm 740nm (2) 421812 - M6 Universal 1 Cam Mount (2) 412519-12 - 12ft Flat Transportable Camera Cable (2) 421805 - M6 Cam 25mm 740nm (2) 421812 - M6 Universal 1 Cam Mount (2) 412519-12 - 12ft Flat Transportable Camera Cable (2) 412713 - M6 Perm Power Cable, No Opus (2) 412995 - Packing Foam Insert (2) 510033-CSC - Car System Version 6.X - EOC Connected		
675	210012 - Shipping Service *ESTIMATE ONLY* Freight from Mesa, AZ - forklift required for delivery	\$4.00	\$2,700.00
2	413133 - Radar Speed Display Trailer RU2 VMS 3370 RADAR TRAILER	\$20,805.00	\$41,610.00

Product Qty	Product/Service	Unit Price	Amount
2	510160 - Data Acquisition Package	\$440.00	\$880.00
2	413030 - WIRELESS MODEM AIRLINK GX450 VERIZON ATT	\$790.00	\$1,580.00
1	530001-HOSTED-SETUP - Hosted EOC Setup (Up to 25 Users)	\$625.00	\$625.00
2	140012 - ELSAG Plate Hunter M6-2 <i>ALPR COMPONENTS</i>	\$11,500.00	\$23,000.00
1	210020 - Tech Dispatch	\$1,250.00	\$1,250.00
2	510322-5.X - EOC Operation Center License 5.X <i>one time software license per system</i>	\$1,275.00	\$2,550.00
1	530001-HOSTED-FIXED - Hosted EOC for Fixed Cameras Per TB required from the Capacity Planner for One Year – Minimum 1 TB	\$2,400.00	\$2,400.00
Subtotals	Goods & Services Sub-total (Pre-tax): Contract Items		\$0.00
	Goods & Services Sub-total (Pre-Tax): Non Contract Items		\$88,045.00
Upfront	Goods & Services Sub-total (Pre-tax):		\$88,045.00
Tax	Tax Rate: 7.750%		\$6,517.36
Total	Goods & Services Total:		\$94,562.36



Quote Offer Terms and Conditions

This Quote constitutes an Offer from Selex ES Inc. (Selex) to Customer, the terms of which become a binding contract between the Parties upon Customer's submitting a Purchase Order to Selex for the Products/Services and prices as identified herein.

Unless the Purchase Order is pursuant to a State or Federal cooperative purchasing agreement, or a separately executed Master Agreement, these Terms and Conditions supersede and replace any prior estimate, offer, quote, agreement, understanding or arrangement whether written or oral between the parties. If there is a discrepancy, please contact your account manager for correction.

These Terms and Conditions may not be changed or modified unless in writing by an authorized representative of Selex. Selex will not be bound by any terms of Buyer's purchase order unless expressly agreed to in writing by an authorized representative of Selex.

Shipment and Delivery. All orders shipped FOB Greensboro.

For purchases of Products that require installation: Unless otherwise agreed to by the Parties, Selex ES agrees not to ship Product until an Installation date is scheduled.

Title. Ownership of and Title to the Products shall transfer to the Customer upon shipment. All intellectual property rights, including without limitation, patents and /or the relevant applications, in or relating to the Products, to the Documentation and to the Software are and shall remain the property of Selex ES or its licensors. **Refer to the Selex Software License Agreement documentation provided with the shipment.**

Payment Terms. Selex shall invoice Customer no later than sixty (60) calendar days after shipment of the Products and/or performance of any Work or Services. Payment is due Net 30 days.

Taxes may not be reflected in this Quote. However, taxes may be added to the amount in the payment invoice(s) sent to Customer, unless Customer provides a certificate confirming tax exempt status.

Cancellation or Delay. Orders accepted by Selex are subject to cancellation by Customer only upon the express written consent of Selex. Upon such cancellation and consent, Selex shall cease all work pertaining to the Customer's order, and Customer shall pay Selex for all work and materials that have been committed to and/or identified in Customer's order plus a cancellation charge as prescribed by Selex.

Warranty. EXCEPT AS SET FORTH IN THIS AGREEMENT AND IN THE SELEX WARRANTY COVERAGE DOCUMENTATION, SELEX INC. MAKES NO OTHER WARRANTIES EXPRESS OR IMPLIED RELATING TO THE PRODUCTS OR SERVICES.

Applicable Law. The terms of this Quote, their interpretation, performance or any breach thereof, shall be construed in accordance with, and all questions with respect thereto shall be determined by, the laws of the state of North Carolina applicable to contracts entered into and wholly to be performed within said state. Any legal proceeding brought by either party pursuant to this Agreement shall be brought in a County or District Court located in Guilford County, North Carolina and the parties irrevocably consent to the jurisdiction of such courts.

FORCE MAJEURE. Either Party shall be excused for delays in delivery or in performance where such delay is directly due to act of God, acts of civil or military authority, fires, strikes, floods, epidemics, war, riot, or other similar causes beyond such Party's reasonable control. Such Party shall promptly give written notice to the other Party specifying the nature and probable extent of such delay. The Parties shall then immediately attempt to determine what fair and reasonable extension of schedules may be necessary. The parties agree to use their best efforts to mitigate the effects of the delay.

COMPLIANCE WITH LAWS. Customer shall comply with all federal, state, local, and territorial laws, including without limitation any export control, employment, tax, anti-corruption, anti-bribery, privacy and data protection, immigration and anti-discrimination laws, and shall indemnify Selex for any liability incurred by Selex as a result of breach of any such obligation.

EXPORT COMPLIANCE. This sale is subject to all laws, rules, regulations and public policies of the United States, particularly those relating to the exportation of goods from the United States and the transmission of technical data or other information outside the United States. By this purchase, Customer agrees to comply with all applicable U.S. laws and regulations which prohibit the export of technical data that originates in the U.S., or any product directly based on such data, without prior written authorization from appropriate U.S. agencies. Such compliance obligates Customer not to export Selex's confidential information or make it available to aliens or any unauthorized personnel, and to indemnify Selex for any liability incurred as a result of breach of such obligation.

**RU2
SYSTEMS**

RU2 Systems

A.L.P.R.

Camera Vault

(Vendor Neutral)

RU2 SYSTEMS
10000 W. 10th Ave. Suite 100
Denver, CO 80202
Tel: 303.755.1234
Fax: 303.755.1235
www.ru2systems.com



RU2 Systems
A.L.P.R.
Camera Vault
(Vendor Neutral)

441



RU2 Systems, Inc.
The Leader in Speed Display Technology

RU2 Systems, Inc.
The Leader in Speed Display Technology





RU2 Systems, Inc.

The Leader in Speed Display Technology

RU2 Fast-3370

VMS Radar Speed Display Trailer



The most versatile Variable Message Radar Sign available, the RU2 Fast-3370 Series Speed Display Trailer has a 30" x 70" full graphic, medium density LED array capable for 1 to 4 lines of text, full graphic characters and complex animation. Whether its speed awareness, a DUI checkpoint, event promotion or traffic management, you can keep the "3370" busy 7 days a week!

The VMS display panel folds down creating a lower trailer profile for easy transport and storage. Its design makes for easy one-person deployment and retrieval. Standard features include an on-line message/graphics library message and "VMS Maker" customization software for both text and animation.

Optional features include solar power assist, wireless communications, ALPR and, our RU2 "Traffic Count" Data Acquisition Package, which records the time, date and speed of oncoming vehicles without the use of dirty and cumbersome pneumatic tubes!

RU2 Systems: The Industry Leader in Speed Display Technology

2631 North Ogden Road, Mesa, AZ 85215

[P] 480-982-2107 [F] 480-982-5237

Toll Free 877-982-2107

e-mail: info@ru2systems.com www.ru2systems.com

Fast-3370 VMS



RU2 Fast-3370 VMS

Variable Message Radar Speed Display

Standard Features:

- Medium density LED matrix with individual LED control
48 rows / 112 columns - 5,376 LEDs
- 30" x 70" active area; 2,56 LEDs per square inch
- Up to 30" Amber AllnGaP LED digits
One to Three lines of text; 1 or 2 @ 19", 2 @ 13", 3 @ 9"
- RU2 "VMS Creator" software included
Over 500 frames of animation / scrolling
- On-line Message/Animation library
- Display protected by 3/16" smoked, non-glare GE Lexan®
- Automatic intensity adjustment to ambient light conditions
- Single directional K-band radar unit
- Keyed On/Off switch
- Four (4) AGM aviation grade batteries (396 A/Hrs. total)
- "Presence Only" VMS mode for power conservation
- Unit defaults to last settings upon power up

Construction:

- 2" AET tubular steel space-frame chassis
- Polyester powder coat finish over high zinc epoxy primer
- (2) Extendable outrigger stabilizers with a swing down swivel tongue jack
- 4.80 x 13 ST tires on 5 lug automotive type hubs
- 2" Class II ball coupler
- Full 7" wide, 14 gauge steel fenders
- 2000 lb rated axle
- Leaf spring suspension
- Taper roller bearings
- Curb Weight: ~940 lbs.

Options Available:

- Solar power – 80/140/280 Watt panel(s)
- Sawtooth machined aluminum wheels
- GPS Vehicle Theft Deterrent System
- Data acquisition package for Counting & Clocking oncoming vehicles
- Wireless communication
- Alarm system, Locking lugs
- Coupler lock, Wheel boot
- Trailer cover
- Spare tire

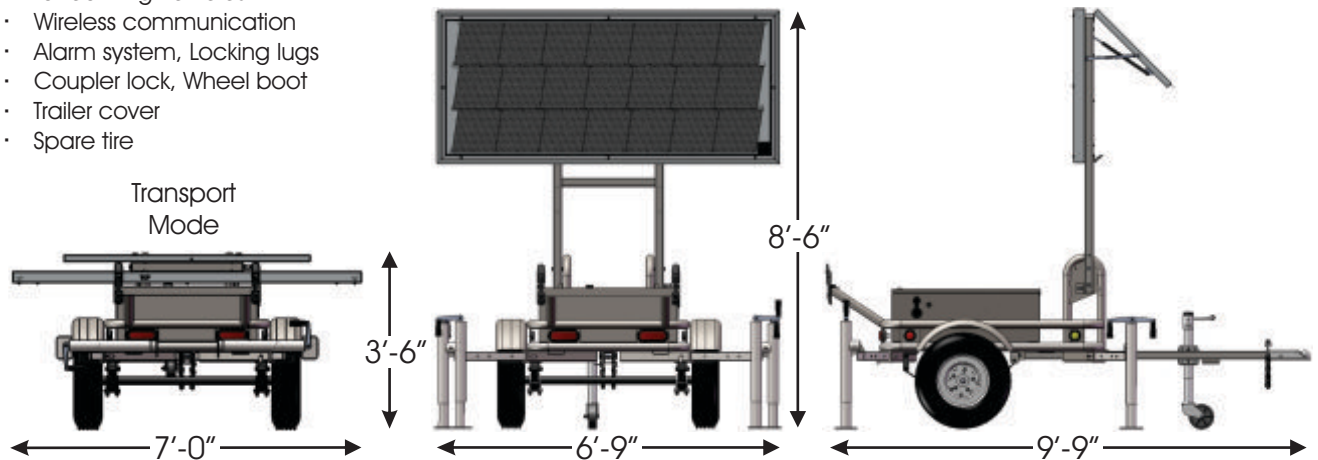
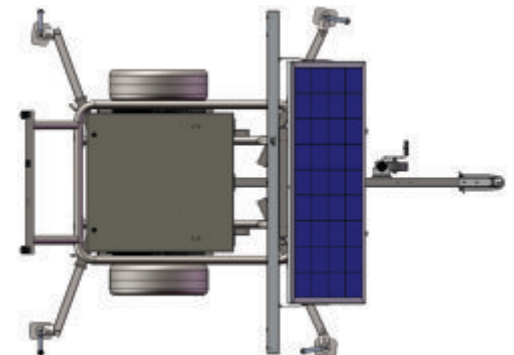

Technical specifications are subject to change without notice.

WARRANTY:

RU2 Systems warrants their LED Displays for Five Years. The Radar Gun is warranted for Two years. On-site labor is not included. However, parts are repaired within five business days of receipt, and include ground-shipping expenses. Warranty does not include physical damage from misuse or vandalism.

RU2 Systems, Inc.
2631 N. Ogden Road
Mesa, AZ 85215

[P] 480-982-2107 [F] 480-982-5237
Toll Free 877-982-2107
www.ru2systems.com

From: Jade Mazzio
Sent: Wednesday, February 20, 2019 6:04 PM PST
To: Noelle Smiley
CC: James Hutchcraft
Subject: FW: Bid Alert: Invited bid for Public Safety CAD/RMS Mobile System Replacement
Attachments: RFP 19-1511.doc, RFP 19-1511.pdf, ATTACHMENT III - Pricing Proposal Matrix.xlsx

FYI- The CAD/RMS project RFP was posted at 6:00pm tonight. Submittals are due March 22 at 4 p.m.

Jade Mazzio | *Business Services Administrator* | ext. 7111

Attachment "III" - Pricing Workbook

Vendor - Add as many lines in section as required. Make sure all subtotals are calculating and remained link the costs summary section at the bottom.

General Pricing Workbook Instructions

All costs must be identified within this pricing workbook. All proposal components (hardware, software, services, maintenance, misc) must be priced separately and identified as a specific System. Shipping costs and taxes must be identified. Vendor may return a copy of the Pricing Workbook as a PDF, but one submitted copy must remain in its native EXCEL format within the printed file and the electronic copy.

1 - Hardware

Vendor will specify the following information (within the description field below) for all proposed hardware including (but not limited to); Make, Model, Type (tower, desktop, rack server. Etc.), Processor Type, Processor Speed, RAM Type, RAM Amount, RAM Speed, OS Type(s) and Version, Hard Drive Type, Number of Hard Drives, Hard Drive Size, Hard Drive Speed, Optical Drive Type, Make and Model of Graphics Cards, Memory and Speed of Graphics Cards, Number of Graphics Cards required per device, Keyboard Type, Mouse Type, Monitor Type and Size, Number of Monitors per device and Warranty. Pricing shall not be "bundled", all hardware and software will be priced on a "per unit bases".

Vendor will use the sections "Proposal Reference Page Number" and " Proposal Reference Section Number" to identify where in their proposal the relevant information can be located.

Item	Description	System (CAD/RMS/Mobile)	Quantity	Unit Price	Extended Price	Notes
					\$0.00	
					\$0.00	
					\$0.00	
					\$0.00	
					\$0.00	
					\$0.00	
					\$0.00	
					\$0.00	
Sub-Total Hardware					\$0.00	

Attachment "III" - Pricing Workbook

Vendor - Add as many lines in section as required. Make sure all subtotals are calculating and remained link the costs summary section at the bottom.

General Pricing Workbook Instructions

All costs must be identified within this pricing workbook. All proposal components (hardware, software, services, maintenance, misc) must be priced separately and identified as a specific System. Shipping costs and taxes must be identified. Vendor may return a copy of the Pricing Workbook as a PDF, but one submitted copy must remain in its native EXCEL format within the printed file and the electronic copy.

2 - Software

Vendor will specify the following information (within the description field below) for all proposed software including (but not limited to); Name, Version and Type (O/S, application, interface). If the Vendor is proposing a "site license", the relevant terms and conditions must be referenced, including; maximum number of licenses (concurrent or consecutive), location and agency restrictions.

Vendor will use the sections "Proposal Reference Page Number" and " Proposal Reference Section Number" to identify where in their proposal the relevant information can be located.

Item	Description	System (CAD/RMS/Mobile)	Quantity	Unit Price	Extended Price	Notes
					\$0.00	
					\$0.00	
					\$0.00	
					\$0.00	
					\$0.00	
					\$0.00	
					\$0.00	
					\$0.00	
					\$0.00	
Sub-Total Software					\$0.00	

Attachment "III" - Pricing Workbook

Vendor - Add as many lines in section as required. Make sure all subtotals are calculating and remained link the costs summary section at the bottom.

General Pricing Workbook Instructions

All costs must be identified within this pricing workbook. All proposal components (hardware, software, services, maintenance, misc) must be priced separately and identified as a specific System. Shipping costs and taxes must be identified. Vendor may return a copy of the Pricing Workbook as a PDF, but one submitted copy must remain in it's native EXCEL format within the printed file and the electronic copy.

3 - Services

Vendor will specify the following information (within the description field below) for all proposed services, including (but not limited to); Project Management, CAD Configuration and Implementation, Interface Configuration and Implementation, Hardware Installation and Setup, Training, Development of Training Materials and Sub-Contractor Oversight.

Item	Description	System (CAD/RMS/Mobile)	Quantity	Unit Price	Extended Price	Notes
					\$0.00	
					\$0.00	
					\$0.00	
					\$0.00	
					\$0.00	
					\$0.00	
					\$0.00	
					\$0.00	
					\$0.00	
Sub-Total Software					\$0.00	

Attachment "III" - Pricing Workbook

Vendor - Add as many lines in section as required. Make sure all subtotals are calculating and remained link the costs summary section at the bottom.

General Pricing Workbook Instructions

All costs must be identified within this pricing workbook. All proposal components (hardware, software, services, maintenance, misc) must be priced separately and identified as a specific System. Shipping costs and taxes must be identified. Vendor may return a copy of the Pricing Workbook as a PDF, but one submitted copy must remain in its native EXCEL format within the printed file and the electronic copy.

4 - Optional Services

All "Optional Services" identified in the RFP are to be included in this section.

Vendor will use the sections "Proposal Reference Page Number" and " Proposal Reference Section Number" to identify where in their proposal the relevant information can be located

Item	Description	Quantity	Unit Price	Extended Price	Notes
				\$0.00	
				\$0.00	
				\$0.00	
				\$0.00	
				\$0.00	
				\$0.00	
				\$0.00	
				\$0.00	
Sub - Total Optional Se				\$0.00	

5 - Maintenance

Vendor will specify the following information (within the description field below) for all proposed maintenance charges including (but not limited to); Proposed Maintenance Period.

Vendor will use the sections "Proposal Reference Page Number" and " Proposal Reference Section Number" to identify where in their proposal the relevant information can be located

Item	Description	System (CAD/RMS/Mobile)	Quantity	Unit Price	Extended Price	Notes
Year 1					\$0.00	
Year 2					\$0.00	
Year 3					\$0.00	
Year 4					\$0.00	
Year 5					\$0.00	
Sub - Total Maintenance					\$0.00	

6 - Miscellaneous

Vendor will specify the following information (within the description field below) for all proposed miscellaneous charges including (but not limited to); Shipping, Travel, Documentation, Printing..etc.

Vendor will use the sections "Proposal Reference Page Number" and " Proposal Reference Section Number" to identify where in their proposal the relevant information can be located.

Item	Description	System (CAD/RMS/Mobile)	Quantity	Unit Price	Extended Price	Notes
Shipping					\$0.00	
					\$0.00	
					\$0.00	
					\$0.00	

Attachment "III" - Pricing Workbook

Vendor - Add as many lines in section as required. Make sure all subtotals are calculating and remained link the costs summary section at the bottom.

General Pricing Workbook Instructions

All costs must be identified within this pricing workbook. All proposal components (hardware, software, services, maintenance, misc) must be priced separately and identified as a specific System. Shipping costs and taxes must be identified. Vendor may return a copy of the Pricing Workbook as a PDF, but one submitted copy must remain in it's native EXCEL format within the printed file and the electronic copy.

					\$0.00	
Sub - Total Miscellaneous					\$0.00	

Attachment "III" - Pricing Workbook

Vendor - Add as many lines in section as required. Make sure all subtotals are calculating and remained link the costs summary section at the bottom.

General Pricing Workbook Instructions

All costs must be identified within this pricing workbook. All proposal components (hardware, software, services, maintenance, misc) must be priced separately and identified as a specific System. Shipping costs and taxes must be identified. Vendor may return a copy of the Pricing Workbook as a PDF, but one submitted copy must remain in it's native EXCEL format within the printed file and the electronic copy.

7 - Project Cost Summary

Item	Extended Price	Notes
7a - System Costs		
Hardware	\$0.00	
Software	\$0.00	
Services	\$0.00	
Maintenance	\$0.00	
Miscellaneous	\$0.00	
Sub-Total System Costs	\$0.00	
7d - Optional Costs		
Sub-Total Optional Cos	\$0.00	
8 - Project Total Costs		
Total All Costs	\$0.00	



Request for Proposals for Public Safety CAD/RMS Mobile System Replacement

RFP NO. 19-1511

KEY RFP DATES

Issue Date: February 20, 2019

Questions Due: March 11, at 4:00 PM

Submittals Due: March 22, at 4:00 PM

CITYOFIRVINE.ORG/PURCHASING

Address:
1 Civic Center Plaza, Irvine, CA

Email Address:
purchasing@cityofirvine.org

TABLE OF CONTENTS

SECTION

- 1. PROPOSER RFP CHECKLIST**
- 2. INTRODUCTION**
- 3. QUESTIONS**
- 4. OVERVIEW AND SCOPE OF SERVICES**
- 5. MINIMUM QUALIFICATIONS REQUIRED FOR PROPOSAL SUBMITTAL**
- 6. EVALUATION AND AWARD SCHEDULE**
- 7. TERMS AND CONDITIONS**
- 8. ORGANIZATION OF PROPOSAL**
- 9. SELECTION PROCESS**
- 10. SUBMITTAL INSTRUCTIONS**
- 11. GENERAL INFORMATION**

ATTACHMENT I – SCOPE OF SERVICES

ATTACHMENT II - AGREEMENT FOR CONSULTING SERVICES

ATTACHMENT III – PRICING PROPOSAL MATRIX

ATTACHMENT IV – CITY TECHNOLOGY STANDARDS

ATTACHMENT V – CITY GIS SERVICES

1. PROPOSER RFP CHECKLIST

- Download the RFP from the City's website.**
- Read the entire document.** Note critical items such as minimum requirements; supplies/services required; proposal submittal dates and format; contract requirements (e.g. insurance, performance and or reporting, etc.)
- Note the City's contact information.** Firms may only contact those listed in the RFP and in the manner and dates specified in this document. Communication with any other City employee, official, or agent regarding the RFP is prohibited.
- Take advantage of the "Question" period.** Submit your questions to the City's contacts by the due date and time listed on the front page of the RFP document. Questions received by the date, time, and manner specified in the RFP will be answered via an addendum.
- Download, review and acknowledge all addenda** issued for the RFP. All addenda are posted on the City's website as stated in the RFP.
- Follow the format required in the RFP** when preparing your response. Provide point-by-point response to all sections in a clear and concise manner. The proposals are evaluated based solely on the information and material provided in your proposal response.
- Upload your proposal on time to the City's website.** Follow the submittal instructions listed in the RFP. Note the submittal date and time listed on the front page of the RFP and be sure to allow enough time to fully submit your response. No late proposals will be accepted. Staff cannot view submissions prior to RFP closing.

2. INTRODUCTION

Thank you for considering the attached Request for Proposals (RFP). If you are interested in submitting a Proposal, please follow these instructions for submissions:

Only RFP documents downloaded from the City's website (www.cityofirvine.org/purchasing) shall be considered official, as the City must track RFP holders in the event an addendum is issued. Failure to download the RFP document and any addendum from the website will result in disqualification of the proposal.

Proposal Submittal: Please refer to the Submittal Instructions section of this RFP for full details. Proposals submitted by any other method such as hard copy or email will be disqualified.

3. QUESTIONS

Any requests for clarification or other questions concerning this RFP must be submitted in writing and sent via email to the following City contacts no later than the date and time specified on the cover page of this RFP.

Jade Mazzio
Business Services Administrator
jmazzio@cityofirvine.org

Brian D. Brown
Senior Buyer
bbrown@cityofirvine.org

4. OVERVIEW AND SCOPE OF SERVICES

The City of Irvine (hereinafter referred to as the "City") is requesting proposals to establish a contract for Public Safety CAD/RMS Mobile System Replacement, with work to commence on or about June 30, 2019 and cutover to be accomplished by December 31, 2020. Scope of Services in accordance with ATTACHMENT I, attached hereto.

5. MINIMUM QUALIFICATIONS REQUIRED FOR PROPOSAL SUBMITTAL

Firms who fail to meet the minimum qualifications set forth below should not submit a proposal; any such proposal shall be deemed non-responsive and not be considered.

- 1) Minimum three (3) most recent years of experience performing similar services as those detailed in the Scope of Services section of this RFP.

6. EVALUATION AND AWARD SCHEDULE*

Review of proposals to be completed by staff	March 29, 2019
Recommendation to department management that the highest-rated firms be interviewed	Week of April 1
If performed, interviews with highest-rated firms	Week of April 1

Recommendation to Purchasing Agent for contract award	April 2019
Recommendation to Finance Commission for City Council recommendation	April 2019
Recommendation to City Council for contract award in open session	May 2019
Contract award	June 2019

***Schedule subject to change**

7. TERMS AND CONDITIONS

Agreement: The City’s standard Agreement for Consulting Services is included as ATTACHMENT II. Upon award of the contract, it is expected that the successful proposer will accept the Agreement terms and conditions “as is” without modification. (Please refer to Part III Special Provisions of ATTACHMENT II for special requirements relating to these services.) The Agreement for Consulting Services will include an as-yet defined Functionality Matrix. The contents of the Functionality Matrix shall be negotiated between the City and the awarded firm.

Respondent’s Proposal: At the discretion of the City, any or all parts of the respondent’s proposal shall be made a binding part of the selected firm’s contract. The City reserves the right to reject in whole or in part any of the proposals.

Insurance Documents: At the time the contract is awarded, the firm must be able to provide all required insurance documentation to the City’s insurance certificate tracking company as set forth in ATTACHMENT II. If these requirements are not met, the City reserves the right to select the next best qualified firm.

Business License: Consultants who provide services for the City of Irvine within the city limits of Irvine shall obtain, within five (5) days of executing this Agreement and prior to commencing any work herein, a City of Irvine business license and shall maintain a current business license throughout the term of this Agreement.

Failure to Execute the Agreement: Failure to execute the Agreement and furnish the required insurance and business license within the required time period shall be just cause for the rescission of the award. If bonds are also required, failure to furnish sufficient bonds shall cause rescission of the award. If the successful proposer refuses or fails to execute the Agreement, the City may award the Agreement to the next highest-rated firm.

8. ORGANIZATION OF PROPOSAL

If your proposal does not include all of the items below, it may be deemed non-responsive. The proposal will be evaluated by the City and shall include, at a minimum, the following information:

- **BUSINESS INFORMATION**

State the full legal name of your firm, including the state of incorporation if applicable. Include your address, phone number, and email address. State the number of years your firm has been doing business. List the names of principals or officers authorized to bind your firm, including position titles.

- **EXPERIENCE/QUALIFICATIONS INFORMATION**

Provide information concerning your firm's experience and qualifications directly related to the services set forth herein. Provide a detailed description of the capabilities/functionality of your firm's proposed solution as it relates to the City's needs which are identified in this RFP document. Include specifics regarding your firm's proven ability to deliver innovative technology. Additionally, this section shall define the experience of the Project Manager, other key personnel and sub-consultants assigned to the project. Include resumes for all managers, supervisors, and other key individuals including sub-consultants who will comprise the team. Demonstrate the relevant expertise and experience of each team member. The designated Project Manager shall be the primary contact with the City during the project period. The proposer (prime consultant) must perform a majority of the services. Proposer shall disclose in the project proposal any and all proposed sub-consultant(s), including details regarding which tasks they would perform.

- **PRICING PROPOSAL**

Provide a fee schedule/pricing information for the project, which must include a project lump sum price. The pricing information must also include the cost for annual software maintenance for the first five years after cutover. Additionally, include hourly rates for each category of employee or sub-consultants required to perform the services as set forth in ATTACHMENT I.

The City shall not provide reimbursement for business or travel-related expenses; therefore, such costs must be absorbed in the hourly rate or lump sum fee structure.

- **PROJECT APPROACH / METHODOLOGY**

Explain in detail how your firm would perform the services required as set forth herein. Describe how the proposed modules integrate with each other to yield a fully-integrated solution. Demonstrate how the requirements and provisions of the scope of this project will be implemented. Demonstrate knowledge of the project's objectives and existing conditions/assumptions; identify potential issues/challenges; and describe your firm's approach to minimize disruptions to performance. Present a comprehensive plan for completing the specified work in accordance with the Scope of Services. The response should demonstrate an efficient use of work force, material resources, equipment, and technology to complete the project within the constraints outlined in the Scope of Services. Provide any additional information that communicates how your team intends to achieve the required outcomes and fulfill the responsibilities of the anticipated contract. If appropriate, a project schedule should be included that details each task and sub-task, the timeframe for each and

showing the total number of calendar days from issuance of the Notice to Proceed through 100% completion of the Scope of Services.

- **REFERENCES**

Provide a minimum of three (3) references for work similar to this scope of services that your firm has provided within the last five (5) years. Include a detailed description of the services, the agency or firm names, contact names, phone numbers, email addresses, and dates of services performed.

- **SIGNATURE**

The proposal shall be signed by an official authorized to bind the firm, including his or her printed name and title.

Proposer shall include a statement to the effect that their firm's proposal is valid for ninety (90) days.

9. SELECTION PROCESS

The contract award will be made after selection of one (1) respondent's proposal from among all respondents with implementation of services to follow. However, this RFP does not indicate a commitment by the City to award a contract to any successful respondent. The City intends to evaluate the proposed services based upon the data presented in response to the RFP. The following general selection criteria will be used to evaluate the proposals:

Phase 1:

1. Capability/Functionality of firms proposed product. Relevant experience, innovation and qualifications of firm and designated project management staff, other key personnel, and sub-consultants, if applicable. (50%)
2. Proposal Pricing (20%)
3. Methodology/Project Approach provided (20%)
4. Responsiveness to the Request for Proposals (10%)

Phase 2 for highest-rated firm(s):

- The City reserves the right to conduct interviews with the highest-rated firm or firms. In the event the City does perform an interview process, the additive weighting shall be 50%.

Phase 3 for highest-rated firm(s):

- The City will perform reference checks for similar work completed within the last five (5) years for the highest-rated firm(s), with an additive weighting of 20%.

The City reserves the right to negotiate final pricing with the most qualified/highest-rated firm(s).

The City reserves the right to reject any or all proposals, to waive any informality in any proposal, and to select the proposal that best meets the City's needs.

10. SUBMITTAL INSTRUCTIONS

Proposals submitted by any other method such as hard copy or email will be disqualified.

Submittals:

- **Must be completed** no later than the date and time specified on the cover sheet of this RFP
 - **Failure to completely upload** your document(s) by the deadline shall result in disqualification
- **May be submitted** at any time prior to the deadline
- Submitted proposal **may be withdrawn and resubmitted** at any time prior to the deadline
- **Large files** may take time to upload; so, plan the timing of your submittal accordingly
- **Cannot be viewed** by City staff until the close date and time

Proposals must be submitted electronically as follows:

Proposals must be submitted electronically by visiting the City's website at www.cityofirvine.org/purchasing. **No other form of submission will be accepted.**

1. Click on the "Supplier Registration and Bid Opportunities" link.
2. Next, click the BidsOnline link and then click "Log In."
3. Enter your User Name and Password.
4. Click "Bid Opportunities" and then select the RFP.
5. Click on "Place eBid" and follow the instructions.

Proposal Document Files

The proposal submittal **requires one (1) file**. Use the naming convention as shown below. Do not exceed 20 characters; abbreviate your firm's name if necessary. **Do not use** symbols such as "\$" as your file may not load correctly.

1. Proposal, including pricing: "CompanyName"

Technical Support

In the event you encounter technical difficulties during the uploading process, please contact the Planet Bids, BidsOnline system team as shown below (M-F from 8 am to 5 pm PST):

support@planetbids.com or call (818) 992-1771 ext. 0

11. GENERAL INFORMATION

Costs

Any costs incurred in the preparation of a proposal, presentation to the City, travel in conjunction with such presentations, or samples of items shall be the responsibility of the respondent. The City assumes no responsibility and no liability for costs incurred by respondents prior to issuance of a contract or purchase order.

Additional Information

The proposer shall furnish the City with such additional information as the City may reasonably require.

Property of the City

All data, documents and other products used or developed during performance of the services will remain the property of the City upon completion of the services.

Payment Terms

The City will make payments monthly on approved invoices, with payment terms of net 30 days upon receipt of invoice. Payment for additional work, if any, will be negotiated as required. Final payment will be made after approval and acceptance of the work. The City of Irvine encourages its vendors to choose electronic payment, either through Electronic Fund Transfer (EFT) or ePayables, in order to promote efficiency.

Sincerely,

Brian D. Brown
Senior Buyer

Attachments

ATTACHMENT I

SCOPE OF SERVICES

Consultant shall perform the services as set forth below.

1 SCOPE OF SERVICES

1.1 *Background Information*

1.1.1 The Community

The City of Irvine, located Orange County, CA was formally incorporated in 1971. The City was formed as a master planned community encompassing many residential villages; commercial centers particularly in the technology and semiconductor sectors with many having their national headquarters within the city; religious institutions and educational institutions such as the University of California Irvine, Concordia University, Brandman University, and satellite campuses for numerous colleges, including University of Southern California, California State University Fullerton, University of La Verne and Pepperdine University – just to name a few.

Fire protection in Irvine is provided by the Orange County Fire Authority (“OCFA”) with ambulance service by a private Consultant. Law enforcement is provided by the Irvine Police Department (“IPD”), staffed with approximately 232 sworn officers and 241 non-sworn personnel. The City of Irvine is rated as having the lowest violent crime rate in the nation among larger cities (population over 100,000 to 499,999) based on FBI statistics. Irvine has held the safest city designation for thirteen consecutive years. Irvine’s 2019 population estimated to be at least 285,000 with continued growth over the next two decades that will likely make Irvine the largest city in Orange County, California.

The agency’s Communications Bureau, located at Police Headquarters (1 Civic Center Plaza, Irvine, CA 92606) provides a central service point for responding to both emergency and non-emergency calls for police and animal services with emergency calls taking preference. Staffing consists of 16 full-time dispatchers and 5 supervisors each of whom are committed to providing exceptional service to the public.

The Communications Bureau receives an average of 200,000 phone calls annually. The Communications Bureau operates with state-of-the-art equipment, including a computer aided dispatch system, GPS automatic vehicle location system, intelligent phone workstations and an 800 MHz trunked radio system. The center is also equipped with a video wall that allows dispatchers to view live video from a closed-circuit TV system, as well as from nearly 130 traffic intersection cameras located throughout the City. This innovative feature helps dispatchers to be more proactive in their duties by providing deployed resources with updates they may be obtaining visually.

1.1.2 Sizing Information Summary

The following information is being provided with the sole purpose of assisting Consultants in sizing the correct solution within their proposals.

Public Safety Employees	Police
Sworn Employees	232
Auxiliary Officers	2
Civilian Employees	241
Total Employee Count	475
CAD Access Equipment	Police
Dispatch and Call Taking	8
Mobile Computers	82
Desktop Computers w CAD Access	16
Desktop Computers w PD RMS Access	300
Public Safety Stats	Police
Calls for Service	187,042
Dispatched Responses, Police & Fire	187.042

1.1.3 Current CAD & Police RMS System

IPD currently utilizes disparate systems to include; Hexagon's I/CAD products, Hexagon's Ileads for records management, Trittech's Copperfire for report writing, DIMS for digital evidence management, Crossroads for citation and accidents reporting and Hyland's OnBase for case and records management.

Approximately 90% of Public Safety staff use the following systems: CAD dispatcher, CAD mobile, CAD web, California Law Enforcement Telecommunication System ("CLETS") interface, jail management, property and evidence management, report writing, investigations, case management, records management, records archiving, custom reports, and database management.

Although the City intends to evaluate the Contractor's total solution for CAD / RMS and Mobile, eExisting Sub-systems may require integration in the event the Consultant's solution does not meet the functionality requirements. These subsystems include a citation and accident reporting application called Crossroads.

The Police Department headquarters and substations are interconnected via fiber and traditional T1 circuits, but the network backbone is primarily 1GB to the desktops. The City standardized with Dell for the desktop computers and Dell OptiPlex 7010 workstations for all the dispatch console positions (all desktops and workstations run Windows 7 Pro 32bit and 64bit). Computer systems are refreshed every three years and MDC's every five years. All networking equipment is Brocade, which may be replaced by CISCO and all servers are HP.

The existing CAD system consists of 7 servers (one physical and 6 virtual). The City uses VMWare's product and plans to remain with VMWare for virtualization. The existing Dell interface servers maintain interfaces for CLETS and ALI-ANI.

Servers run Win2k8. The City's Directory Services/Domain are planned to be upgraded to either Windows 2008 or Windows 2012. The City's database standard is Microsoft SQL.

1.2 Project Goals

With a new CAD and RMS, the City's ability to prevent, respond to, manage, and analyze situations threatening the safety and property of citizens, and provide other critical emergency services

resources will be significantly enhanced. An integrated Police and RMS System will lay the foundation for intelligence led policing, enhanced criminal justice, and overall strategic public safety resource deployment.

The system must advance the overall mission, goals, and objectives of the City by making public safety personnel more effective in preventing, combating, and responding to public safety matters through strategic resource deployment.

The City is aware of current industry technologies and is seeking a balance between mainstream and state-of-the-art technology. The City wants to employ solutions that will prolong the life of the new system and postpone the need for replacement. The City envisions that the system will be based upon current, proven technology that is derived from current industry and City standards.

1.2.1 CAD, RMS and Mobile Systems Objectives

The system must be able to perform so that an operator will not have to wait for critical information and will rarely have to wait for routine information.

The system must utilize an easily understandable user interface that optimizes efficiency and the viewing of critical data in real time. Users must be able to filter information according to their preferences utilizing the mouse, hot keys and/or command line functionality. All critical functions must be accessible via the keyboard, as mousing between entries is discouraged.

The system must be easily configurable and permit the System Administrator to create, update, and manage the key records and tables, dialog boxes, status monitors, and masks, as well as create, modify, and, print reports.

The proposed solution must adhere to City's technology standards. The standards are consistent with those being adopted by public safety entities throughout the country, as well as with the interoperability standards adopted by the US Federal government. The "City Technology Standards" is being provided as Attachment "IV" within this RFP.

The system must be in compliance with Section 508 of the Rehabilitation Act of 1973, as amended (29 U.S.C. §792).

The City is increasingly adopting the .Net platform for new development and interfaces utilizing XML-based web services. Thin client applications are preferred. This consideration is critical for new and upgraded applications in the public safety arena where appropriate.

The underlying IT Infrastructure (Network, Computer, Storage) must be built on the WINTEL Platform (current version minus one), the database should be MS SQL Server, and capable of virtualization with VMware's ESX hypervisor platform. The underlying storage must offer three tiers of block level storage; Solid-State Drive ("SSD"), Serial-Attached Storage ("SAS"), Serial AT Attachment ("SATA") and dynamically move data between each tier based on access frequency.

1.3 Services

1.3.1 Project Management Services

Major City information technology projects, including the CAD, RMS and Mobile Replacement project, are managed by Consultant specific subject matter experts ("SME") and project

managers reporting to the City Project Manager as the primary lead in this project. Project sponsorship is through business units and City resources for the project are staffed and managed through a matrix management project structure. A project steering committee will oversee the CAD, RMS and Mobile project. The City expects significant project management activities to include, but not be limited to, Project Scheduling, Risk Management, Cost Management, Change Control Management, Communications Management and on-site meetings as (and when) required.

Prior to contract signing, the Consultant shall prepare and submit to the City Project Manager for approval a Statement of Work to include;

- a. Draft proposed schedule,
- b. All features of Consultants base system that are available in the base system price
- c. All features request via the functional matrix and the cost of each
- d. Annual maintenance costs, and
- e. Final Implementation Plan

1.3.2 Project Schedule

Consultant must provide draft project schedule in Microsoft Project format utilizing a Work Breakdown Structure (“WBS”) format including resources and milestones. The intent of the City is to develop and maintain a shared project schedule that includes all Consultant and City tasks and activities. Implementation schedule should incorporate the major subproject implementation phases such as CAD, RMS, Mobile, etc.

1.3.3 Consultant Project Staffing Plan

Given the high-profile nature of this project, the City expects best in class project management services from the Consultant. The City expects the Consultant shall work closely in conjunction with City’s Project Manager. The City will only accept Consultant personnel who have significant and relevant experience with the Consultant’s CAD, RMS and Mobile system and can show a successful track record at locations of similar size and complexity as the City.

Consultant shall:

- a. Identity proposed staffing resources and level of effort for each major task. Consultant must also include an organization chart for proposed project personnel, including proposed sub-Consultants.
- b. Describe expectation of City staffing resources and Level of Effort for each major phase, including expected skill set needed to successfully complete each task.
- c. List key personnel that will be assigned to the project.
- d. Provide resumes of all key staff that provides enough information to allow the City to evaluate their capability and qualifications to perform proposed tasks.
- e. Describe roles and tasks for all key personnel for each major phase of the project,
- f. Identify whether this is their major assignment, and a projection of other assignments they may be working on during the implementation period.
- g. Describe for all key personnel what percentage of time will be on project.
- h. Provide information regarding who will be on site for each major phase of the project, and who will be remote.
- i. Provide the Consultant’s escalation process of issues.
- j. Describe facilities and equipment that the City is required to provide on-site staff.

- k. Submit all Consultant personnel assigned to work on-site on the CAD, RMS and Mobile project to undergo a criminal history check. Off-site personnel may also be subject to a criminal history check. Please note that arrangements for required criminal history checks should be made in advance with appropriate City personnel. The City reserves the right to reject any personnel proposed by the Consultant for any reason. All key personnel will be required to sign a confidentiality agreement for access to sensitive data.
- l. Ensure that support personnel proposed have the necessary level of training and experience with the application suite to ensure that the City is receiving expert-level support. The Consultant may be requested to provide the City with a listing of all certificates, training courses and other relevant evidence to document the level of expertise of proposed support personnel.
- m. Understand that the Consultant's Project Manager is expected to coordinate and participate in all activities related to Consultant demonstrations.

1.3.4 Project Reporting

The Consultant shall participate, at a minimum, in a bi-weekly Project Meeting to report progress toward contract deliverables, update status from the previous reporting period, and advise current objectives, problems or delay issues, proposed corrections and other relevant information.

1.3.5 Project Status Reports

The Consultant's Project Manager shall provide, at a minimum, bi-weekly project status reports detailing relevant information to the City's Project Manager.

1.3.6 Implementation Management Plan

The City uses the Project Management Book of Knowledge ("PMBOK") as a guide for implementation of all projects. Please provide how the Consultant's implementation planning activities incorporate all of the major PMBOK phases: Initiation, Planning Execution, Monitoring & Control, and Closing. For each phase, Consultant shall:

- a. Provide the Consultant's process to complete each major phase (i.e. CAD, RMS, Mobile, AFR, etc.);
- b. Provide the Consultant's methodology to prepare servers (i.e., completed on-site or at the Consultant's location);
- c. Provide the Consultant's Deployment plan of all phases and why this methodology is being proposed;
- d. Provide the Consultant's Risk Management plan that shall be used to ensure successful implementation of all phases;
- e. Provide the Consultant's Quality Management plan that shall be used to ensure successful implementation of all phases; and
- f. Provide any Change Management solutions provided by the Consultant that are a component of the proposal.

1.3.7 Training

The Consultant shall develop a training work plan and curriculum to be approved by the City project manager in conjunction with City personnel. The work plan should also include periodic follow-up and update training when a new release or version of any application is installed. The

Consultant must develop a training plan and curriculum that specifies the required training and technical staff supporting the application. The Consultant's City-approved training schedule must be closely coordinated with City staff to coincide with the installation of the software and hardware. Upon acceptance by the City Project Manager, the Consultant shall implement said approved plan.

The City requires a hybrid training approach that utilizes both Consultant-supplied trainers, as well as a train-the-trainer capability. All initial CAD, RMS and Mobile training shall be performed by Consultant training City personnel as trainers. Thereafter, the Consultant shall shadow a training session conducted by the City trainers, who will become responsible for completing the rest of the training sessions. The shadow period is expected to run for one (1) class for each training type (dispatchers, records, field personnel and administrators).

The City requires an optional provision to have each of the dispatchers trained by the Consultant, as opposed to a train-the-trainer approach. This option will be determined at the time training is to commence and will be based on the comfort level of the project team.

The City will work with and assist the Consultant in the scheduling of the initial shadow training programs. The City shall provide space adequate for conducting the training and housing and securing the training equipment.

Given the shift assignments of public safety personnel, training courses will often need to be scheduled outside of normal working hours, including weekends and evenings. In order to keep the training relevant to the ultimate system look-and-feel, as well as fresh as possible and still accommodate the necessary number of sessions, it is expected that training will not begin until after preliminary system acceptance and before cut-over, but in no case will begin longer than 30 days prior to the scheduled "Go-live" date.

If the system Go-live date is significantly delayed due to the Consultant's actions or faults, any repeat training sessions as determined by the City must be performed at no cost to the City.

With some exceptions (e.g. System Administration training), classes will contain no more than 6 trainees for CAD training and no more than 12 trainees for RMS and Mobile systems and will not last longer than eight hours.

The Consultant shall be responsible for providing training materials and take-away documents such as user manuals and user guides and cheat sheets to adequately perform the initial training and provide follow-up reference material for the trainees. These documents should also be provided in an electronic format.

The Consultant must provide a comprehensive training program minimally covering:

- a. PSAP personnel user training;
- b. Police field personnel;
- c. Agency-Based supervisory personnel;
- d. Standard and ad hoc reporting;
- e. Records personnel
- f. CAD/RMS/Mobile system administration (including Consultant supplied Interfaces);
- g. CAD technical Operations; and
- h. GIS Functions and Operation

1.3.8 Data Conversion

It is the City's desire to have historical data from CAD and RMS systems accessible, resident or not, within the new CAD, RMS and Mobile solution. It is imperative that all historical data is either archived or maintained in a manner that allows querying of the data from the new proposed system or is converted and added to the new proposed system.

Consultants are encouraged to use their expertise in this area to provide the City applicable options in the form of a Data Conversion. The City understands there may be many methodologies available to manage legacy data in a cost-effective and user-friendly manner. The City is seeking to migrate the following data from the legacy systems:

- a. Incidents,
- b. Incident Premise History,
- c. Case Reports,
- d. Case Narratives,
- e. Case Persons,
- f. Case Property,
- g. Case Vehicles,
- h. Arrests and Associated Booking records,
- i. Case Attachments,
- j. Historical Case Report Requests,
- k. Field Interviews,
- l. Citations Data and Attachments,
- m. Accident Reports and Attachments,
- n. Pawns
- o. Equipment Lists,
- p. Personnel Data,
- q. Master Name Index,
- r. Master Property Index, and
- s. Master Locations Index,

The Consultant shall include a description of all Consultant and City processes and activities required to successfully migrate legacy data from the legacy systems into the Consultant's proposed solution. The study should include the following:

- a. The Consultant's proposed data conversion process;
- b. Specific functionality and features of the proposed solution(s). For example, precise information how City personnel would access the historical data;
- c. Specific roles and responsibilities for proposed City resources, as well as recommended skills of personnel required to perform City tasks;
- d. Specific roles and responsibilities for proposed Consultant resources, as well as recommended skills of personnel required to perform City tasks;
- e. Qualification, experience and resumes of Consultant staff proposed for the Data Conversion Task;
- f. A description of the Consultant's proposed automated data conversion tools;
- g. Recommended solutions for end-users to access non-migrated legacy data via integrated system or separate queries;
- h. Recommended storage location for non-migrated legacy data;

- i. Any prior data conversion experience with the City's legacy systems. Please list the relevant projects, the versions involved, and provide contact information for the clients. We are particularly interested in projects that involved the proposed Data Conversion personnel; and
- j. The Consultant shall include a description of its process for implementing data conversion and archiving legacy data.

Consultants shall provide pricing estimates and recommended methodology for conversion based on converting ten years of data from Hexagon's I/CAD, ILEADS and Hyland's OnBase

1.3.9 Operational Migration Plan

The migration from one CAD, RMS and Mobile system to a new one can present significant threats to the health and safety of the public and first responders if problems arise. The City CAD cutover will take place in its existing Communications Center and will require an extraordinary level of coordination and staging to avoid impacting existing operations.

Cut-over activities shall be approved in advance by the City. A cut-over working group composed of City, CAD, RMS and Mobile Consultant and other relevant personnel will be formed to develop a detailed migration plan and the actual execution of the CAD, RMS and Mobile system cut-over.

1.4 General Software Requirements

1.4.1 GIS Requirements

The City uses an ESRI GIS database. Consultant must interface with this database to develop the geo-file required for the proposed systems. The interface should be designed to load an initial file from the City's GIS and to also periodically enable updates of CAD, RMS and Mobile system's geo-file from the City's GIS database. The Consultant must provide the tools necessary for City GIS staff to perform the geo-file creation and upload process. Specific details of the City's GIS Services are outlined within this RFP in "Attachment "V", City GIS Services"

1.4.2 Browser Based Functionality

The proposed solution must include browser-based functionality. This functionality allows authorized staff to access the system from non-dispatch or call taking terminals utilizing a thin or thick client. The browser-based functionality must include:

- a. The ability to see all CAD activity in real time;
- b. The ability to see the CAD GIS map, including available units, units on calls, calls holding, active calls, etc.;
- c. The ability to send and receive messages within the system, including individuals, units, dispatch positions, call taking positions, etc.; and
- d. The ability to access information within the system, including all call information, all unit information, all timestamps, all AVL/GPS data and routing information to any location.

1.4.3 Data Purging

The system must have a purge facility that will off-load data from the servers for archival storage, access, and/or destruction. Purging must be administrator-configurable by multiple parameters. All purges must be subject to strict audit tracking and reporting and must occur while the system is fully operational, without degradation of performance.

1.4.4 Back-up and Recovery

The servers must have an appropriate automated back-up capability for system and application back-up and transactional level recovery. Back-up media shall be in a format suitable for convenient off-site storage. The system must provide differential back-up schedules for various system components and be configurable by the system administrator. Incremental and full back-up capabilities must be provided. All back-up and recovery processes must be subject to auditing and reporting. System back-ups must be accomplished without taking the application out of service and without degradation of performance or disruption to operations.

The City desires to utilize its existing backup system to perform all necessary backups providing for full-restore should an event occur that requires it. A full restore means that all primary and ancillary systems that are being backed up are restored and fully functional. If specific backup parameters are required by the Consultant, please describe those requirements in detail. If the proposal includes backup alternatives, it is required to specify the system, cost, and methodologies that will be used to accomplish the back-up and recovery of the system.

The City's current Back-Up and Recovery Software and process is more fully described in the "City Technology Standards" being provided as Attachment "IV" within this RFP.

1.4.5 CAD Stand-Alone Mode

The CAD workstations must have the ability to operate in a stand-alone, off-line mode in the event the CAD servers become unavailable. At a minimum, the system must provide the ability to track basic unit availability and status information in a standalone mode.

1.4.6 Automatic Update of Workstations/MDCs

All software updates to both desktop CAD and RMS workstations and MDC computer terminals must be accomplished through an automated network facility and not require a technician to perform a manual procedure on each workstation/MDC. This update utility must be configurable by multiple parameters, e.g., workstation type, and able to support the scheduling of update activities in batch and non-batch modes. A summary report is required, documenting the results of the update activity.

1.4.7 Data Integrity

The system must ensure the integrity of the data which it maintains. Interruptions in processing due to incidents such as aborted transactions, hardware failures, or network unavailability must not result in inaccurate or inconsistent data in the system. If data transfers occur, the system must provide a method of audit validation to ensure that all data sent was received in the target application.

1.4.8 Coding

The system shall be developed utilizing a current programming language such as .NET Framework, ASP.NET MVC, or other language acceptable to the City. The City requires Consultants to actively advance development technologies as provided by industry standards and not maintain any portion of the proposed solution with technology that is outdated, end of life, end of support, etc. The Consultant must disclose the programming language used in the proposed solution.

1.4.9 Scalability

Future requirements for regional cooperation and interoperability will only increase. Since this may result in the system being subjected to a greater than normal amount of traffic, the system must be able to scale up to handle the additional load without any performance impact, specifically on the CAD operations. Increased loads of up to 50 percent may be the result of temporary surges based on a major event. Also, the need may arise to permanently increase the standard capabilities of the system. The former will be handled by building in excess capacity over historical trends, the latter by seamlessly adding hardware and software components to adapt to the new workload. Adding or upgrading hardware components must be accomplished without bringing the system down or negatively affecting its performance.

1.4.10 Flexibility

The system shall be able to retain its performance levels when adding additional users, functions and data. The solution functionality and associated business rules must be able to be configured with the use of applications or functions that do not require "code" modifications. The screens shall be highly configurable, providing ability to reposition and rename field labels, remove or "turn-off" unused fields, maintain data, and allow the addition of user-defined fields. The system shall provide the ability to create and/or modify business rules.

1.4.11 System Reliability/Availability and Access

The public safety mission requires consistent operations, at a minimum 99.999% up time. Routine maintenance or administrative procedures must not require system "down-time" or a re-start to take effect.

1.4.12 System Administration

The proposed solution must provide a suite of system administration tools to support the effective ongoing operation of the systems. The full suite of system administration tools shall be available to appropriate City personnel. System administration capabilities, at a minimum, must include the ability to:

- a. Create and maintain user and group accounts;
- b. Integrate with Active Directory to allow for single sign on;
- c. Manage security (as described below);
- d. Manage back-up and recovery processes;
- e. Monitor and tune system performance;
- f. Install and configure hardware;
- g. Install and configure software/updates;
- h. Interface with ESRI Web Services and google maps for updating CAD geo data;
- i. Monitor and maintain interfaces;
- j. Schedule procedures (staff, assignments);
- k. Schedule report distribution;
- l. Manage disaster recovery procedures;
- m. Configure alerts;
- n. Organize and maintain system documentation; and
- o. Perform remote management.

The systems must allow the System Administrator to configure by jurisdiction, agency, or user group the display of all available information, including maps, status screens, event forms, call

entry screen, dispatch screens, and pull-down menus. Changes to one agency/jurisdiction/user-group configuration must not affect any other agency/jurisdiction/user-group configurations.

The System Administrator must be able to modify the layout and data elements displayed on all Consultant supplied forms and screen masks, and the ability to create macros or shortcuts for common user functions.

The System Administrator or other authorized user must also be able to add a report, macro, or function to the application menu and add new data elements to forms or report formats.

All system administration procedures must be supported by a detailed logging, auditing and reporting capability.

1.4.13 Database Administration

The full suite of database administration tools and capabilities for the system must be available to the City. These include, but are not limited to, the ability to:

- a. Alter on-screen field attributes, i.e., positioning, labels, drop-down lists;
- b. Specify edit and validation checks on fields;
- c. Modify content of drop-down lists; radio button lists, etc.;
- d. Perform system diagnostics;
- e. Monitor and tune database performance;
- f. Perform database back-up and recovery;
- g. Execute queries;
- h. Download data directly into Microsoft Excel, Microsoft Access, and SQL Server format;
- i. Support integration via web services;
- j. Configure alerts; and
- k. Log and archive all database activity.

Database imports and exports must be accomplished with minimal impact on system performance and must maintain the integrity of all relational linkages. Import/export tools must support both automated and ad hoc operations.

All database administration procedures must be supported by a detailed logging, auditing and reporting capability. Changes to one agency/jurisdiction/user-group configuration must not affect any other agency/jurisdiction/user-group configurations.

1.4.14 Security

A mission-critical application affecting the safety of the public, as well as the City's first responders, the system must be supported by robust security controls. Security considerations to be addressed minimally include: hardware and networks; application security; user identification and authentication; and multi-jurisdictional considerations.

Multiple firewalls, encryption, anti-virus software, intrusion detection, advanced authentication for remote users and LDAP authentication are all utilized within the existing City's systems. Software must support the City's virus scanning software.

All hardware implemented within the City networks must go through a security review and be certified by the City Information Services Manager for compliance with the City standards.

1.4.15 Security Requirements

The system/security administrator must have, at a minimum, the ability to assign different user profiles based on individual and group classifications and sub-classifications and assign differential access privileges. To protect HIPAA, CJIS and other restricted data, the System Administrator must have the ability to define security profiles down to the individual data field level. Profiles must support read-only access and selective read/write privileges. Security profiles must also be able to be assigned to individual devices such as workstations and printers.

Secure Platform Application: The Consultant must support deployment of host server and database security patches and service pack updates within one month of patch release (e.g., application running on Windows server Operating System (“OS”) should not limit installation security patches on host operating system). Application and Consultant must support new operating system versions within one year of release. Application security vulnerabilities shall be remediated with the development, testing and timely release of security patches by the application Consultant within three calendar months of the vulnerability being identified.

User Authentication/Single Sign-on (SSO): The City standard for a single point of user authentication is Microsoft Active Directory (“AD”), using the Lightweight Directory Access Protocol (“LDAP”). The City standard for authentication is to allow properly authorized users to login just once on their computer and be able to access all approved applications during that active session.

Secure Authentication: All authentication activity occurring over the network should be encrypted using FIPS to ensure that logins and passwords are not transmitted in clear text. This includes using FIPS 140-2 (at a minimum) and administrator authentication activity.

Sensitive Data: Applications containing or hosting sensitive data, as defined by State of California or US Federal law or regulation, shall encrypt data at rest, using (at a minimum) FIPS 140-2, data in motion over the network and all authentication activity. Encryption algorithm used to encrypt data and authorization activity shall be industry standard.

Auditing and Logging: Application must log all security-related events including logon, logoff, data modification, data deletion, change in rights or permission levels, and the addition of data/information to the application. Logs must include user ID generating the transaction, time of the transaction, and details regarding the activity (e.g., logon, logoff or data details). System should support interoperability with centralized logging and Security Information Event Management (“SIEM”) technologies.

Compliance with Organization’s Security Policy, Standards and Procedures - Application Consultants working directly on City-owned applications or from City facilities are subject to all City policies, standards and guidelines.

Specific security information for the City’s Public Safety Network is provided in the “City Technology Standards” being provided as Attachment “IV”.

1.4.16 Application Security Coding Requirements

- a. Parameter Manipulation: Applications shall be designed to ensure that parameter manipulation does not provide access to data or application functionality that the user is not authorized to see or use.
- b. Input Validation: Sanitize all user input fields to ensure that cross-site scripting, SQL injection and other input related vulnerabilities are closed through secure application coding. Input validation should be performed on the server/application and not on the client devices.
- c. Hidden Fields: System should not use “hidden fields” for Security.
- d. Cookies: System should not rely on cookies to define security settings. Cookies must not contain or be used to obtain sensitive information.
- e. Session Identifiers: If system uses session identifiers, they should be generated with unpredictable numbers and should contain enough key space to prevent unauthorized use or guessing of the session ID’s.
- f. Error Messages: System should handle system errors in an appropriate manner. Failed login attempts to the system should not generate detailed information about the failed login attempt (e.g., incorrect password or unknown user account). Other security related errors (e.g., file not found, or permission denied) should generate generic error responses. Detailed error information should be written to secure logs so that developers and system administrators have access to error details required to address the error. Error messages should be clear.

1.4.17 National & State Public Safety Data Standards

The US Federal government has taken the lead recently in developing standards for facilitating information sharing among local, state and federal first responders and emergency operations managers. The proposed CAD, RMS and Mobile applications must comply and be maintained to these standards.

Deviations from the architecture and standards may represent a barrier to the implementation of the City’s public safety integration and interoperability goals and may be reviewed with prejudice. All Consultants must specifically disclose all aspects of the proposed solution which deviate from the documented standards and desired architectures and provide approaches for consideration about the way non-standard components may be integrated.

The US Federal government, California Department of Justice and other parties, such as APCO, occasionally update and improve the referenced standards or develop new ones. In that the City may adopt such future standards, it is mandatory that the CAD Consultant monitor these developments and upgrade their offerings as necessary to comply.

The time between purchase of a CAD system and its implementation may be significant; therefore, it is possible that updated standards may have been released in the interim. The City shall not accept products that will be outdated by the time they are implemented. It shall be the Consultants responsibility to verify and validate all new standards as they are implemented. The City shall not be responsible for determining when new standards are required.

Consultants are encouraged to review the standards and comply at minimum to the standards associated with each of the following:

NIBRS - National Incident Based Reporting System, CIBRS - California Incident Based Reporting System and UCR-Uniform Crime Report

Capture data to report official crime statistics to the Federal Bureau of Investigation under Uniform Crime Report (“UCR”), National Incident-Based Reporting System (“NIBRS”) and California Incident-Based Reporting System (“CIBRS”), once approved by California DOJ, implemented to improve the overall quality of crime data collected by law enforcement, captures details on each single crime incident—as well as on separate offenses within the same incident—including information on victims, known offenders, relationships between victims and offenders, arrestees, weapons, and property/evidence involved in the crimes.

<https://ucr.fbi.gov/nibrs-overview>

NIEM - National Information Exchange Mode

NIEM is a product developed by the Office of Justice Programs in the US Department of Justice and adopted by the US Department of Homeland Security. NIEM describes XML schema for a variety of attributes associated with incidents and events including NCIC and NIBRS. The schemas allow for the easy sharing of data among disparate agencies and are becoming the de-facto incident-based integration and interoperability standard. Having CAD NIEM-compatible XML schemas available in a depository is required to improve the City’s ability to quickly respond to current and future data-sharing requirements. The Consultant’s solution must specifically meet Global Justice Extensible Markup Language Data Model (“GJXDM”).

<http://www.niem.gov/>

<http://it.ojp.gov/jxdm/>

LEITSC - Law Enforcement Information Technology Standards Council

The LEITSC was established by the Office of Justice Programs in the US Department of Justice to foster integrated justice systems through the definition and implementation of standards of CAD and RMS systems.

https://it.ojp.gov/documents/leitsc_law_enforcement_rms_systems.pdf

https://it.ojp.gov/documents/leitsc_law_enforcement_cad_systems.pdf

NENA – National Emergency Number Association

NENA provides 9-1-1 policy, technology, operations and education standards for public safety communication centers. The City has adopted the standards for ALI Data Exchange, ALI Response and GIS Mapping as a minimum standard. As the technology advances, the City requires compliance for NG 9-1-1 standards as adapted by NENA.

<https://www.nena.org/>

Next-Gen 9-1-1

Consultant must be prepared to meet all existing and proposed Next-Gen 9-1-1 functionality, including VOIP, Voice to Text, Text to 911, Video Submission and T.D.D. requirements.

<http://www.its.dot.gov/ng911/>

HIPAA - Health Insurance Portability and Accountability Act of 1996

HIPAA requires, among other things, that the privacy and security of protected health information be assured. This includes such information as may be transmitted and/or stored by electronic systems, including via wireless telecommunications. The CAD, RMS and Mobile systems must comply with the requirements of the law and the proposal must identify the steps taken to test and certify compliance with the standard prior to implementation.

<http://www.hhs.gov/ocr/privacy/>

CJIS Security Policy – Criminal Justice Information Services Security Policy

The CJIS Security Policy provides Criminal Justice Agencies (“CJA”) and Noncriminal Justice Agencies (“NCJA”) with a minimum set of security requirements for access to Federal Bureau of Investigation (“FBI”) Criminal Justice Information Services (“CJIS”) Division systems and information and to protect and safeguard Criminal Justice Information (“CJI”). The CAD, RMS and Mobile systems must comply with the policy and the proposal must identify the steps taken to certify compliance with the standards prior to implementation.

<http://www.fbi.gov/about-us/cjis/cjis-security-policy-resource-center/view>

CLETS - California Law Enforcement Telecommunications System

California Law Enforcement Telecommunications System (“CLETS”) is an efficient law enforcement communications network available to all public agencies of law enforcement within the state. The CLETS provides all law enforcement and criminal justice user agencies with the capability of obtaining information directly from federal and state computerized information files. The CAD, RMS and Mobile systems must adhere to the statutes established in the CLETS Policies, Practices and Procedures publication.

<http://oag.ca.gov/>

RIPA – Racial and Identify Profiling Act

The Racial and Identity Profiling Act of 2015 (“RIPA”)(AB953) requires each state and local law enforcement agency to annually report to the Attorney General data on all stops, as defined, conducted by the agency’s peace officers, and require that data to include specified information, including the time, date, and location of the stop, and the reason for the stop. The RIPA Board has established a requirement of reporting stop data by April 1, 2019. Specific required data elements are defined in Article 3. Data Elements to be Reports of the California Code of Regulations, Title 11. LAW, Division 1. ENFORCEMENT, Chapter 19, Final Text of Regulations. The proposed systems must comply with the RIPA stop data reporting requirements no later than the earliest of the dates required by the RIPA Board. Consultants must submit specification on how the proposed solution shall collect all required data elements and how the data will be reported via a secure file transfer or web service to the California Department of Justice Stop Data Collection System (“SDCS”)

<https://oag.ca.gov/sites/all/files/agweb/pdfs/ripa/stop-data-reg-final-text-110717.pdf?>

APCO - The Association of Public-Safety Communications Officials

APCO is an international leader committed to providing complete public safety communications expertise, professional development, technical assistance, advocacy and outreach to benefit and the public. APCO is an American National Standards Institute (“ANSI”)-Accredited Standards Developer (“ASD”) that develops standards for public safety communications. The CAD system must comply with these standards and the proposal must identify the steps taken to certify compliance with the standards.

<https://www.apcointl.org/>

1.5 CAD Software Requirements

The City requires the proposed CAD solution to be fully integrated with RMS and Mobile, with neither of these systems provided by a third party. The CAD solution must meet the same general requirements as depicted in “Section 1.4, General Software Requirements”.

The proposed CAD system shall facilitate incident response and communication with operations in the field. The system allows operations and communications to be augmented, assisted, or partially controlled by atomization that includes the ability for computer-controlled resource dispatching, resource status management, incident reporting and analytical information. The system must be optimized for rapid response time and system reliability. Because time is of the essence, the system must accurately provide a date and time-stamp for every activity. The system must be capable of interfacing with more than one RMS system and support the exchange of data between other agency CAD systems.

The CAD solution must be designed to conform to the national standard for computer aided dispatch functional specifications, Unified Computer-Aided Dispatch Functional Requirements (“UCADFR”), developed by the LEITSC and the Law Enforcement Information Sharing Program (“LEISP”) technical standards of the U.S. Department of Justice’s (“US DOJ”) Global Justice Extensible Markup Language (“XML”) Data Model (Global “JXDM”).

https://it.ojp.gov/documents/LEITSC_Law_Enforcement_CAD_Systems.pdf

For all exchanges generated by CAD, conformance with US DOJ’s Global JXDM is required.

The City desires a hosted or cloud-based system over a traditional server-client based solution requiring in-house expertise to support and maintain the infrastructure and software suite.

The CAD application must support complex, agency-defined resource recommendation algorithms that meet the needs of the public safety users. Resource recommendations must be based on either AVL locations and/or Patrol Beat, depending on the event type. The CAD application must maintain and track public safety resources by status and location provided by real-time AVL.

The CAD application must support complex event distribution based on event location, service agency, service type, and/or jurisdiction. Certain event types must automatically create “linked” events for multiple agencies/services and distribute each to the appropriate dispatch position.

The systems must meet the following performance specifications as measured by maximum response time. Response time is measured as the time between a user-initiated command via any mode and the return of the requested data or action from the system. The system must (at a minimum) provide 99.999% uptime performance.

Transaction	Maximum Response Time
Locally attached CAD workstations, no external data access	1 second
Locally attached CAD workstations, geo-file validation required	2 second
Locally attached CAD workstations, non-CAD data access required	3 second
Locally attached Report Server, simple query	2 second
Locally attached Report Server, complex query	3 second
Standalone MDC computer, single record access	1 second

NOTE: For each transaction listed, 95% of the occurrences must complete within the specified Maximum Response Time.

A workstation shall be deemed to be locally attached when it is in the same premise and on the same physical network as the application server. All CAD workstations located in the PSAP will be locally attached on a 1GB network backbone with 100MB to the desktop.

The maximum response time for CAD queries that necessitate access to data sources outside the City's computing environment, such as a mutual aid request or CLETS lookup, shall be measured as the response time provided by the external source plus three (3) seconds.

Response times for MDC computers shall be measured in standalone mode to discount any wireless network latency.

1.6 MDC Software Requirements

The City requires the proposed Mobile solution to be fully integrated with CAD and RMS, with neither of these systems provided by a third party. It is expected that the Mobile application will be an extension of CAD and RMS, providing the necessary functionality of a public safety user to receive and manage an incident and to further initiate and complete the reporting of an incident into the RMS system. The Mobile solution must meet the same general requirements as depicted in "Section 1.4, General Software Requirements".

The proposed Mobile system shall facilitate communication between operations in the field and the communication center, specifically for the atomization of notification of a Call for Service from the CAD to the MDC. The CAD application's Mobile component must provide the public safety user with real-time, incident-specific information. Information must be accessible with minimal effort by the operator. Routine queries and status functions must be form-driven or single function key/screen press, minimizing the need to type commands.

The Mobile environment must support multiple applications, such as mapping and field-based reporting while maintaining CAD status, messaging, and dispatch functionality as the primary operation. Third party software applications must be able to co-exist on the same mobile hardware without impacting the performance of the Mobile solution.

The City's MDC's are configured with software to provide advanced authentication as required by the CLETS and the FBI CJIS Security Policy. Specific details of the City's mobile security standards are depicted in Attachment "IV", City Technology Standards, within this RFP.

The proposed solution must be fully capable of being deployed on the City's existing hardware and operating system. The City utilizes Panasonic CF-33, Getac F110 and Getac T800 ruggedized mobile computers for police and civilian vehicles. Each MDC are equipped with a GPS chipset and accesses the City's secured network by Verizon Wireless as their public wireless carrier.

The proposed mobile solution must be capable of being utilized on a smart devices or similar functionality must be provided within an application to be used on a smart device.

1.7 RMS Software Requirements

The City requires the proposed RMS solution to be fully integrated with CAD and Mobile and be developed as a native solution and not provided by a third party. The RMS solution must meet the same general requirements as depicted in "Section 1.4, General Software Requirements".

The proposed Law Enforcement RMS solution shall provide for the storage, retrieval, retention, manipulation, archiving, and viewing of information, records, documents, or files pertaining to law enforcement operations and cover the entire life span of records development, from the initial generation of the case file to its completion. The RMS solution, at minimum, shall provide for the

following business functions: calls for service, incident reporting, booking, investigative case management, property and evidence management, arrests, warrants, traffic accident reporting, citations, field interviews/contacts, registrants, pawns, civil process orders and restraints, permits and licenses, equipment and asset management, fleet management, personnel, and analytical support (crime analysis).

The RMS solution must be designed to conform to technical standards by the US DOJ Global Justice Extensible Markup Language (XML) Data Model (Global JXDM).

The RMS shall provide, at a minimum, the following general requirements: single entry (i.e., no duplicate data entry); automatic submission of data to external sources; maximization of the utilization of code tables; provide the ability to enter and query narrative(s)/text fields; spell check and formatting capability on narrative(s)/ text fields; provide the ability to access multiple systems from a single RMS workstation; utilization of a single database (virtual or physical); validation on data entry (i.e., logical edits, edit checks for all fields); and provide the ability for operators to generate inquiries to internal (i.e., CAD and RMS) and external data sources (i.e., CLETS, NCIC, DMV, LinX) from within each module where such inquiries make sense.

The proposed RMS solution must provide the operator with, at a minimum, the ability to reuse and/or import data returned from external sources to eliminate redundant data entry. RMS must provide the capability to electronically forward RMS data to external data sources, either automatically or upon the user's request (i.e., based on agency rules embedded within RMS). The above capabilities should be based on existing and emerging criminal justice standards, including DOJ's Global JXDM; the NIEM; and the National Institute of Science and Technology (NIST), including the Electronic Fingerprint Transmission Specification (EFTS) and Facial Recognition Collection standards.

The proposed RMS solution must have basic master indices that correlate and aggregate information in the following areas: people, locations, property, conveyances (e.g., vehicles), and organizations (including businesses and gangs). Master indices eliminate redundant data entry by allowing the reuse of previously stored information and the automatic update of the master indices upon the entry of report information. Master indices information should be captured in a variety of ways to include, at a minimum during the input of, information from an incident, traffic accident, vehicle reports, citation, booking, arrest, juvenile, fingerprint, and mug shot subsystems. Prior to accepting an entry, RMS should automatically give the user the option of determining whether there is a match based on existing data. The system should support the validation and linking of addresses, commonplace names, and street intersections. Linkages among any information contained in the master indices (e.g., people to places or person to person) must be included in RMS.

The proposed RMS solution must be compatible with third party reporting tools such as Crystal Reports. The City requires the solution to provide standard reports for Federal and State Statistical Reporting, including Uniform Crime Reporting ("UCR") and National Incident Based Reporting System ("NIBRS").

The proposed RMS solution must be capable of being utilized on an MDC and a smart devices or similar functionality must be provided within an application to be used on a smart device.

1.8 Interface Software Requirements

The CAD/Mobile/RMS must be designed to operate as a component of a tightly integrated, comprehensive, multi-jurisdictional, multi-agency, multi-user, incident based public safety system. Therefore, the proposed solution must interface with several of the City's ancillary systems. For each interface, all functionality will be fully described within a Functional Specification Document ("FSD") that will be developed by the Consultant and approved by the City. The FSD shall be developed and approved after the Consultant is selected but before any work begins on the interface. In the event a standard interface exists, the Consultant shall provide, in response to this RFP, the capabilities and functionality of each interface by submitting the FSD. Each interface, if appropriate, must operate from the CAD, Mobile, RMS & Smart Device platforms.

1.8.1 ANI/ALI

An interface with the City's Public Safety Answering Points ("PSAP") software, VIPER® is required. The interface must enable incoming E9-1-1 ANI/ALI data to be automatically mapped to corresponding address and phone data fields based on the Master Street Address Guide ("MSAG") standard in the CFS event entry form and geo-locate the location of the caller on the CAD map display. The interface must support all E9-1-1 ANI/ALI formats including wire-line, Wireless Phase I and Wireless Phase II, Voice over IP, and Multi-Line Telephone Systems. The interface must enable the insertion of additional fields captured in the CFS event, including ESN, call type (landline, wireless), and ANI/ALI tracking ID (if available).

If the Consultant has an integrated PSAP software application as part of the CFS process, the integration shall be included as standard functionality and not be delivered nor implemented as a secondary option.

Next Generation 9-1-1 (NG-9-1-1)

The Consultant shall be responsible for progressive research and development of new technologies as they relate to NG-9-1-1 to be capable of receiving cellular calls, text messages, instant messaging, legacy 9-1-1 calls (wireline), telematics (automatic crash notification) data directly from the vehicle, VoIP calls, and live video feeds. The Consultant shall include this functionality as standard functionality and not be delivered nor implemented as a secondary option.

The Consultant shall describe their vision, both immediate and long-term, for CAD-integrated Next Generation 9-1-1 services. This should include a description of NG9-1-1-associated data management (receipt, case integration, storage and retention), as well as access for both CAD and mobile users. The Consultant shall describe any NG9-1-1-related capabilities, functionality and features of the proposed CAD system, including any integration of NG9-1-1 data into the CAD call workflow.

To the extent that the functional elements of NG9-1-1 are defined, The Consultant is required to describe the proposed solution's ability to meet NENA i3 (08-002/08-003) and associated standards. The City recognizes that current NENA standards do not specifically address core CAD functionality; however, it is clear that there are points of interaction with standardized i3 functional elements. Consultant shall describe how the proposed CAD solution will be updated as new and revised standards, functionalities and features are developed, as well as how data elements from NG9-1-1 and CAD are managed to ensure data received from NG9-1-1 is usable without extensive reformatting by the CAD solution.

References:

<http://www.its.dot.gov/ng911/>
http://www.nena.org/?page=FuncIntrface_NG911

1.8.2 Alarm Monitoring Company Public Safety Answering Point

The City is anticipating implementing an interface to provide the atomization between an Alarm Monitoring Company and the City's Public Safety Answer Point ("PSAP"). The proposed solution must be capable of establishing a bi-directional interface to receive an initial notification of an alarm event and provide status updates by the PSAP to the initiating alarm company. Bi directional updates may include the request for cancellation by the alarm company, updates by the key-holders information, notifications by the PSAP of the primary response along with associated status changes such as a unit being dispatched, arriving on scene and closing of the incident with disposition.

<https://www.apcointl.org/resources/interoperability/asap-to-psap/asap-to-psap-protocol/>
<https://www.apcointl.org/download/alarm-monitoring-company-to-psap-cad-automated-secure-alarm-protocol-asap/?wpdmdl=5938>

1.8.3 License Plate Reader – Vigilant Solutions

The City Police Department uses a License Plate Reader ("LPR") system by Vigilant Solutions. Vigilant Solutions provides the capability to interface their technology with CAD to assist in automating alerts within CAD and/or the MDC's for matches against various hotlists. The proposed solution must provide the ability to interface with Vigilant Solutions Mobile LPR solution.

1.8.4 Radio Console Interface / Push to Talk

The City utilizes Project 25 ("P25") compliant fixed mount and portable radios by Motorola in conjunction with a Motorola MCC 7500 IP Dispatch Console. The proposed solution must provide ability to display on a CAD workstation, the radio Push to Talk ("PTT") IDs and EIDs (Emergency IDs) when received by the dispatcher for Police. The IDs must include the Unit Radio Name (i.e. 100M or E1...etc.) and the location, by address or cross street as determined by GPS data provided by the P25 compliant radio. In addition, the proposed solution must also display "Action Commands" as entered in the field on an MDC or other mobile device, i.e. "Acknowledged", "Enroute", "Staged", "Onscene", "Clear", "Change Location", etc.

1.8.5 Global Positioning System (GPS) / Automatic Vehicle Location (AVL)

The City requires that the CAD/Mobile/Smart Device applications utilize the most current, real-time to near real-time location of each police vehicle and/or personnel. Latitude and Longitude information needs to be converted to address data and appropriately displayed on the integrated CAD and Mobile maps. The CAD and Mobile applications must be able to manually poll any GPS-equipped vehicle or person by assigned radio, MDC and/or Smart Device. The CAD and Mobile applications must be configurable to control the automatic polling update rate based on location, status, time and/or distance, or any combination thereof. GPS data is available from following:

Mobile Data Computers: The City utilizes a Panasonic and Getac Rugged Tablet equipped with a built in GPS chipset in police vehicles. The system must be capable of being configured to track the location of the MDC as the primary method of receiving GPS data for vehicle location.

Radio System: The City utilizes Motorola P25 compliant radios equipped with an internal GPS receiver and should be used as the primary, or secondary method of receiving GPS data. The system should be capable of being configured to track the location of the portable radio if the portable radio assigned to an officer is not within a defined perimeter of the vehicle they are assigned to.

Cellular/Smart Devices: The City utilizes a variety of cellular enabled smart devices to include, Apple IOS, Android and Windows based operating systems. Most devices are equipped with Assisted GPS (A-GPS). The system should be capable of being configured to track the location of the smart device assigned to an officer, and if necessary, be a secondary method of tracking the location of the assigned officer if the smart devices is not within a defined perimeter of the vehicle they are assigned to.

1.8.6 Records Check System

The City requires an interface be implemented to provide the ability to access and complete either; queries, locating, entering, modifying, clearing, cancelling, and or commenting on records on multiple systems either individually, or a combination thereof.

The Records Check system must be capable of accessing; agency local databases such as CAD and RMS, state databases such as the CLETS and DMV, National Databases such as NLETS/NCIC, Local Databases such as the local Orange County Automated Telecommunications System ("OCATS") system and the regional LInX and CopLink Databases.

In addition, the Consultants must provide their experience in completing each of the following interfaces and where applicable, provide the experience in working with specific applications that are depicted below.

1.8.7 California Dept of Justice CLETS

The City requires an interface to; the CLETS for the purpose of accessing files of the CJIS, the Department of Motor Vehicles ("DMV"), the National Crime Information Center ("NCIC"), and the National Law Enforcement Telecommunications System ("NLETS") over the California Department of Justice ("CA DoJ") secure telecommunication backbone. Connectivity to the CLETS is through the Orange County Sheriff's Department's OCATS message switch. The Orange County Sheriff's Department is the CLETS Direct Interfaces System Host for Orange County.

The interface shall be designed to handle all CLETS traffic; transmitting and receiving responses to inquiries, entries and updates, and the processing of administrative messages such as All-Point Bulletins on a statewide or nationwide basis.

The CLETS interface must provide for all data forms currently available for the CLETS system to complete queries, locating, entering, modifying, clearing, cancelling, and or commenting on records including LoJack records. The interface must be able to "nest" queries (example, when a registered owner's information is returned from a vehicle tag query, the system automatically runs the registered owner's information, etc.).

The interface shall present the returned CLETS information in a formatted display with capability to add specific returned information as a supplement to the CAD incident or RMS record, or be forwarded to an MDC or smart device application. The proposed solution shall also provide for the display of images (mug shots, driver's license or ID photos, etc.).

The interface shall provide the ability to “spawn” additional queries based on the information returned from a previous query to any other interfaced database. The ability to generate spawned queries shall be configurable by a system administrator (example, when a return from CLETS is received and the info contains the name of an individual, the system shall spawn an additional query to the regional LInX database).

The proposed solution should provide the ability to perform multiple simultaneous searches from a single-entry screen form (i.e. with a single entry of identifying information in a query) and automatically search CLETS, NCIC, DMV, local databases via OCATS, and the resident CAD, RMS and BOLO files, etc.

1.8.8 Orange County Automated Telecommunications System (“OCATS”)

The Orange County Sheriff’s Department maintains a message switch, known as OCATS for local subscribing agencies to inquiry and update records within the local Automated Jail System (“AJS”), Automated Warrant Services System (“AWSS”), and the Local Arrest Records System (“LARS”). The City intends to maintain its direct interface with OCATS for performing queries of the local systems similar to the CLETS system. OCATS has established an established protocol for CAD and RMS providers. The proposed solution must provide for the simultaneous query of both CLETS and the OCATS system.

1.8.9 Law Enforcement Information Exchange (“LInX”)

The City is a participating member of the So Cal LInX Region. LInX is a national cooperative law enforcement data share consisting of participating members of municipal, county, state and federal law enforcement agencies broken down into 12 regions, primarily in jurisdictions with military bases nearby.

The LInX database consists of law enforcement data to include: Incident Reports, Accident Reports, Warrants, Arrest Reports, Booking Records, Field Interviews/Contacts, Pawn Shop Records, Citations, Traffic Stops, Sexual Offender Registry, Mugshots, Photo’s Associated with Record Types, Narratives and Supplemental Narratives.

LInX has established a web service interface using NIEM-based LEXS S/R standards, specifically, Global Justice Extensible Markup Language Data Model (“GJXDM”).

<http://it.ojp.gov/jxdm/>

The proposed solution must provide the ability to export data to the LInX system with the ability to control what data and when the data shall be sent with the ability to restrict sensitive data. In addition to providing data to LInX, the City intends to have a direct interface with LInX for performing queries of the LInX database similar to queries of the CLETS system. The proposed solution must provide for the simultaneous query of both CLETS and LInX.

1.8.10 California Dept of Justice - Cal-Photo

The California Department of Justice (“DOJ”) Cal-Photo application provides law enforcement users with the ability to search and retrieve DMV images from DMV, and Mugshot images from the various connected Law Enforcement Agency (“LEA”) image databases throughout California. These images are instantly available through an XML for a computer to computer interface using

a custom interface. The proposed solution must provide for the simultaneous query of Cal-Photo in conjunction with CLETS queries.

1.8.11 California Dept of Corrections and Rehabilitation - Parole LEADS

The CDCR has an externally published web service to enable law enforcement agencies the ability to automate inquiries via a Simple Object Access Protocol ("SOAP"). The proposed solution must provide an option to simultaneously query the Parole LEADS system in conjunction with CLETS queries.

1.8.12 Forensic Logic (formerly CopLink)

Similar to LinX, the City is a participating member of CopLink. CopLink, now owned by Forensic Logic, is a data sharing and crime analytics platform designed to help law enforcement organizations by providing tactical, strategic and command-level access to vast quantities seemingly unrelated data.

<https://forensiclogic.com/platform/>

The CopLink database consists of law enforcement data to include: Incident Reports, Accident Reports, Warrants, Arrest Reports, Booking Records, Field Interviews/Contacts, Pawn Shop Records, Citations, Traffic Stops, Sexual Offender Registry, Mugshots, Photo's Associated with Record Types, Narratives and Supplemental Narratives.

The proposed solution must provide the ability to export data to the CopLink system with the ability to control what data and when the data shall be sent with the ability to restrict sensitive data. In addition to providing data to CopLink, the City intends to have a direct interface with CopLink for performing queries of the CopLink database similar to queries of the CLETS system. The proposed solution must provide for the simultaneous query of both CLETS and CopLink.

1.8.13 Crossroads Software – Citation, Analytics and Report Writing

The City utilizes Crossroads Software for citations and collision reports. The software provides for analytics and report writing functions. Crossroads provides a desktop application as well as a mobile application on a handheld device with Microsoft Windows Mobile Operating System. Data from these devices is synchronized with a centralized server which is interfaced with the Orange County Court. The proposed solution must provide the ability to interface with Crossroads for ingesting Citation and Accident data elements, and associated attachments to a report to include file formats consistent with pictures and portal document format ("PDF").
LJTEapon4jsf

If the proposed solution includes an Accident and/or Citation module as part of the solution, the Consultant should provide details of the functionality and whether the module can be run on a hand-held device utilized in the field. An interface with Orange County Courts will be required.

1.8.14 License Plate Reader – Vigilant Solutions

The City Police Department utilizes a License Plate Reader (“LPR”) system by Vigilant Solutions. Vigilant Solutions provides the capability to interface their technology with CAD to assist in automating alerts within CAD and/or the MDC’s for matches against various hotlists. The proposed solution must provide the ability to interface with the LPR solution to alert dispatchers and patrol officers on a hot hit from a stationary trailer or vehicle mounted reader. Upon recognition of a hot hit, the CAD system shall receive the location of reader at the time of the hot hit, and the captured photo and an indication of the status of the plate, whether lost, stolen, or if the vehicle is wanted or of interest. Upon receipt of a hot hit, the CAD system must complete an automated CLETS query. The CAD system must create a call for service/incident, utilizing the location provided by the hot hit, and if from a vehicle mounted reader, assign the unit to the incident. Further requirements will be defined in an interface functional specification.

1.8.15 California Highway Patrol - Allied Agencies to SWITRS Reporting Services

The California Highway Patrol (“CHP”) Allied Agencies Reporting Service (“AARS”) has developed a system for Allied Agencies (“AA”) to transmit collision data electronically to the CHP Statewide Integrated Traffic Records System (“SWITRS”) by way of a web service known as AARS Web (Collision) Reporting Service. The proposed solution must provide the ability to interface with the AARS Web Reporting Service for electronic submission of collision data.

1.8.16 LiveScan

The City utilizes live scan hardware to capture and store biometrics that includes fingerprints, data and a mugshot to the regional Cal-ID system. The proposed solution must provide the ability to interface with the live scan hardware to provide data required by the live scan system to eliminate the need to manually re-enter data. In addition, the interface must be capable of ingesting a mugshot provided by the live scan system and associating it with master name record the RMS.

1.8.17 Lexis Nexis – Desk Officer Reporting System

The City has implemented a citizen self-reporting system called Desk Officer Reporting System (“DORS”) by Lexis Nexis. The DORS system is exposed to the citizens by way of the City’s website. The City is currently allowing citizens to submit report on: attempted thefts, petty theft, mail theft, lost property, vandalism and vehicle tampering and allowing citizens to file for a bicycle license or request patrol checks for home while vacationing. The proposed solution must be capable of ingesting the information from the DORS system and created associated calls for service and case files within the RMS system.

https://risk.lexisnexis.com/-/media/files/government/dors_brochure-pdf.pdf

1.8.18 Orange County District Attorney – Electronic Direction for Compliant

The City is interested in interfacing directly with the Orange County District Attorney (“DA”) to submit arrest and case information electronically to the DA’s Case Management System via their Electronic Directions for Complaint (“EDC”) interface. The DA’s IT Department is currently developing an API for the interface. The proposed solution must be capable of sending arrest and case related information to the CA and provide the ability for a user to determine the data

and associated case reports and attachments to be sent. Given this interface is new to the DA, the DA may be open working the CAD/RMS provider to comply with a current interface deployed.

1.8.19 Video Management System

The City utilizes an array of camera systems and has access to private camera systems throughout the City. The proposed solution must be capable of integrating with these systems to provide a display of the physical location of each camera, the cameras field of view, and provide a link to access and display the live feed of the selected camera or cameras.

1.8.20 Body Warn Camera / Dash Mount Camera Metadata Tagging

The City currently utilizes dash mount camera and will be deploying body-worn cameras in the future. The proposed solution must provide an interface to provide data to be utilized for tagging videos. Data element should include the incident ID, type of incident, location of incident, the unit(s) assigned to the incident, the personnel assigned to the incident, and time stamp to be utilized to associate status changes during the incident. Further requirements will be defined in an interface functional specification.

1.8.21 CAD-to-CAD Interface

The purpose of the CAD-to-CAD interface is to connect disparate CAD systems for the purpose of exchanging data to assist in the transfer or receipt of a call for service of neighboring police agencies and to allow the transfer of each agencies resources location and status information.

The proposed interface functionality, whether a single instance for multiple CAD system or a single instance for each CAD connection, must be capable of, but not limited to, the following: establishing a heartbeat to monitor the connectivity of the two systems; sending and receiving incident data; establishing a link between the incidents on either end for updates; acknowledgment of receipt of an incident; assigned resource identification and corresponding status changes of each assigned resource; resource position (GPS) or location sharing; incident cancellation processing; request for shared resources; and messaging between the two CAD systems. The interface shall provide an audit trail of the exchanged information to enable research by way of querying the data.

Ideally, the CAD-to-CAD interface in its basic function is a single data exchange switch facilitating the exchange of data between each of the disparate CAD systems to enable a dispatcher on either end of the interface to visually monitor the current location and status of neighboring agencies resources and to enable the CAD system to make resource response recommendations based on the known real-time location and proximity of the resources, regardless of which agency the resource belongs to. Initiation of the request for resource response shall be automated by sending incident information and the requested resources to the neighboring agency's CAD system. Upon receipt, the receiving dispatcher shall manually accept or deny the request and manage the dispatching functions resident to their CAD system.

The City wants to explore an interface for each of the following agencies:

1. Orange County Fire Authority ("OCFA"). The interface would be with Tellus (formerly FatPot) which is interfaced with the OCFA TriTech CAD system.
2. Orange County Sheriff's Department ("OCSD"). The interface would be direct with the agency's TriTech CAD system.

1.8.22 Tow Provider Interface

The City currently contracts with several tow providers and utilizes a rotation process to identify which provider is to be utilized when a request for tow is initiated. The City desires an output from the CAD for service requests that could be sent via an email, a page or SMS text, a fax, or an interface to the tow provider CAD system. The City may, in the future, integrate with a regional system dispatching and tracking system. The proposed solution must provide the capability of a notification at minimum. Further requirements will be defined in an interface functional specification.

1.8.23 DIMS Digital Information Management System

The City utilizes Linear DIMS Software for digital evidence. The software manages the acquisition of digital images and video. If the proposed solution includes a digital evidence module as part of the solution, the Consultant should provide details of the functionality. If the functionality of DIMS is preferred the proposed solution must provide the ability to interface with DIMS.

1.9 *System Testing, Reliability and Acceptance*

The City requires a system acceptance process comprised of at least the following components; the System Test Period, the System Reliability Period, and the Final System Acceptance as described further below. During the System Test Period and the System Reliability Period, if the system reveals any major defects or several minor defects impacting the completion of testing and/or production use of the system, the process shall be terminated, and the Consultant shall reasonably resolve outstanding issues. Once the issues have been addressed, the Consultant will recommence. The Consultant shall describe its trouble reporting, priority, and severity plan for this process. The Consultant shall describe responses to failed user acceptance tests, including when the testing must be held in abeyance, and recommenced in its entirety from the beginning as may be required by the City.

1.9.1 System Test Period

The Consultant's software shall be delivered to the City accompanied with written documentation stating the system is ready for testing and a draft acceptance test plan ("ATP") for the City to use in its acceptance testing process. The City will review the written draft of the testing plan and schedule the installation of the software within the City test environment. The acceptance test period shall begin when the City, along with the assistance of the Consultant, first performs all tests in accordance with the ATP and successfully completes the tests. If major defects or numerous minor defects are found during the acceptance testing, the tests shall be terminated, and the Consultant shall resolve outstanding issues.

Once all issues have been addressed, the Consultant will recommence the ATP process, in its entirety, from the beginning as may be required by the City.

The Consultant shall provide the City with draft test plans that include, but is not necessarily limited to the following:

- a. Drafting a test plan for City staff;
- b. User acceptance testing;
- c. Product performance testing;

- d. Interfaces testing;
- e. Security testing;
- f. Data conversion testing;
- g. Hardware and network capacity testing;
- h. Integration testing;
- i. Load testing; and
- j. Fail-over testing.

The City shall be responsible for conducting a final unit, subsystem, and system acceptance test that shall include, but is not necessarily limited to, the following:

- a. Testing all software components in accordance with published functions and features;
- b. Testing all software components;
- c. Testing all system software based on business scenarios;
- d. Testing all system software based on user friendliness;
- e. Testing of all contracted interfaces based on design and business scenario;
- f. Parallel testing prior to cutover (if parallel processing is appropriate);
- g. Security testing;
- h. Data Conversion testing;
- i. Testing based on business scenarios;
- j. Hardware and network capacity testing;
- k. Integration testing;
- l. Load testing; and
- m. Fail-over testing.

The Consultant shall review the City's additions to the test plans for accuracy and completeness. The City reserves the right to revise the test plans provided that reasonable notice is given to the Consultant. The City maintains sole authority to certify the successful completion of any and all tests performed by the Consultant on the proposed system.

1.9.2 System Reliability Period

After the successful completion of the cutover period, there shall be a minimum of ninety (90) day reliability testing during which the newly installed system will be in production and its performance monitored. During this period, the system must perform fully without degradation of any kind for the System Reliability Period to be satisfied. If any major defects or numerous minor defects are discovered, the System Reliability Period shall be terminated, and the Consultant shall resolve all issues. Once all issues have been addressed, the Consultant shall recommence the System Reliability Period, in its entirety, from the beginning as may be required by the City.

Severity levels pertaining to the system are defined as:

Severity Level 1 (S1): Critical system errors, which are defined as: Loss of Data, Corruption of Data, or Loss of Productive Use of the System. In the event this type of error occurs, the City shall immediately notify Consultant and the ninety (90) day Reliability period shall be cancelled. Consultant personnel shall promptly resolve the problem at no additional cost and a new ninety (90) day Reliability period shall begin. Once the system operates for (90) consecutive days without a Severity Level 1, the ninety (90) day Reliability test shall be completed.

Severity Level 2 (S2): Critical errors exist when the primary purpose of the Consultant's CAD/Mobile software is compromised, and productive use of the system is significantly impacted. A procedural workaround is either not immediately or readily available or has been proposed and has been found to be unacceptable by the City. In the event this type of error occurs, the City shall immediately notify the Consultant and the ninety (90) day Reliability period shall be suspended. The Consultant's personnel shall promptly resolve the problem at no additional cost to the City, and the ninety (90) day Reliability period shall re-commence at the point where it was suspended.

Severity Level 3 (S3): Non-critical errors which are defined as incomplete operation of system where a procedural workaround is readily and immediately available, and productive use of the system is not significantly impacted on software or operations. In the event this type of error occurs, the City shall immediately notify the Consultant, but the ninety (90) day Reliability period shall continue. If possible, the Consultant shall resolve the problem during the ninety (90) day Reliability period, but if necessary, resolve in a future bug fixes release of the product.

Severity Level 4 (S4): Cosmetic errors which are defined as configuration issues that can be corrected by the City, data integrity issues that must be addressed by the City, Help File documentation errors, or enhancements that can be made in the future to the presently installed system. Severity level 4 defects shall be remedied within a future software fixes release.

1.9.3 Final System Acceptance

At the successful completion of the System Reliability Period and completion of all data conversions, and demonstration they system backup and recovery features function successfully, the City shall issue final acceptance certificate.

1.10 *Hardware Requirements*

All hardware must be new equipment delivered in the manufacturers' original packaging and carrying the manufacturers' full warranty. The warranty period begins after system acceptance and certification by the City that the equipment is in production use. All equipment must be installed according to manufacturers' requirements.

All hardware components must be sized appropriately to ensure that the performance requirements of the Consultant's application will be met. Equipment specifications provided by the City within this RFP shall be considered as minimal requirements. All servers provided by the Consultant shall, at a minimum, meet the City Technology Standards as outlined in Attachment "IV" within this RFP.

Consultant must provide servers and workstations that meet the following minimum requirements:

1.10.1 CAD Servers:

The Consultant shall furnish and install the necessary Servers to support the CAD and all Interfaces and Report Server(s). All server architecture must comply with the City's IS Technology Standards provided in Attachment "IV" in this RFP, and leverage VMware's virtualization technology and Industry Standard 3rd Party Automated Tools to facilitate high-availability and immediate failover from a network, computer, and storage layer.

The Consultant shall recommend the quantity and provide such servers as to meet or exceed the minimum requirements of their software and the required performance standards delineated within this RFP.

The operating system kernel may not be modified. All support for hardware redundancy must be provided by Consultant-supplied middleware and firmware that can be upgraded as required.

The solution must provide the guaranteed availability of 99.999% uptime (at a minimum), utilizing fully redundant hardware i.e., functionally critical hardware within the single server must be duplexed. Interface and Report Servers are not required to be fault tolerant. For the primary CAD servers, the following components must be fully redundant, at minimum:

Motherboard, including CPU chipsets and Memory DIMMs

The motherboards must be completely encased for safety, and designed to allow insertion and removal, for repair, without shutting down the operating system, or the applications.

Disk Drives

All disk drives in the proposed solution must use RAID 1 mirroring (*at a minimum*). This data protection must be provided with redundant SAS controllers that perform all Input/Output (“I/O”) operations across a redundant bus. The mirror technique must be implemented in a fashion that has no performance penalty. All disk drives must be completely encased for safety, and designed to allow insertion and removal, for repair, without shutting down the operating system, or the applications.

Power Cords

Two external, twist-locking power cords are required for the proposed solution. The server must have onboard dual power supplies with dual power cords connected to two separate and distinct Uninterruptible Power Supplies connected to two separate power circuits.

For security reasons, all encased components must be designed so that City personnel and/or operational staff can be trained in the replacement of failed parts. Replacement parts must be shipped to the City utilizing a priority overnight carrier with guaranteed delivery.

The proposed server solution must contain self-diagnosing logic that will determine, based on error thresholds, if a component is failing. Once that determination is made, and without human intervention, the server must be capable of contacting the supplying Consultant and requesting replacement components.

The Consultant shall maintain a support infrastructure that is fully operational 24 hours per day, and seven days per week. This infrastructure must be global in nature, and also accept calls from City personnel as they have questions or issues pertaining to the proposed solution.

1.10.2 Workstations

The Consultant shall furnish and install six (6) workstations to support the Operations, Training, and Testing environments. The Consultant shall provide such workstations as to meet or exceed

the minimum requirements of their software and the required performance standards delineated within this RFP. All workstation architecture must comply with the City's IS Technology Standards as outlined in Attachment "IV" within this RFP.

1.10.3 Position Requirements

- a. Eight (8) – Combination Dispatch and Call Taking Positions
- b. Site License – Mobile Computers
- c. Site License – Browser Based Functionality
- d. Site License – Police Records Management System
- e. Site License – Records Check System

1.10.4 CAD Printers

The Consultant shall provide two (2) laser printers to support the printing of reports. The printer must have a network interface controller ("NIC") installed. All printers, at a minimum, must comply with the City's IS Technology Standards as outlined in Attachment "IV" within this RFP.

1.11 Licenses

Consultants shall provide a copy of all end user software license agreements ("EULA") that they will be requesting the City to execute.

1.12 Maintenance, Support and Updates

The Consultant shall make available to the City all updates to the software, as they are released, at no additional charge, so long as the City is currently under the Consultant's software maintenance agreement. To ensure that documentation is consistent with the operating environment, updated documentation must be delivered concurrently with the software update.

1.13 Warrant

The Consultant shall include in its proposal a list and description of warranties provided, including, but not limited to:

- a. Warrant of Performance – one-year performance warranty covering the specifications for and performance of all software and services, commencing upon system acceptance;
- b. Warrant of representations made by Consultant in response to RFP;
- c. Warrant Against Viruses – Consultant warrants against deliberate time bombs – encrypted key technology to disable the system or otherwise hinder system functionality;
- d. Warrant of Consultant Capability – Consultant is financially viable and there are no legal proceedings against the Consultant that could jeopardize this agreement;
- e. Warrant of Past Success – System is installed and running at other similar locations, and there is no pending litigation against the Consultant based upon problems with the system and Consultant performance;
- f. Configuration Warrant – Consultant warrants that the system provided and installed includes all components necessary to perform the processing presented; and
- g. Release Warrant – Consultant warrants the combination of hardware, software, and operating system requirements.
- h. Product Continuance Warrant- Consultant warrants the continuance of their product including incorporating state and federal mandates, and/or the ability to transition without cost to their refreshed product line.

1.14 **Quality Control**

This RFP requires the establishment of a quality control system by the Consultant to ensure that hardware and software supplies and/or services meet the quality standards explicitly and implicitly specified in this RFP. The quality control system, including procedures, is subject to surveillance by the City.

The quality control system and procedures shall be designed by the Consultant. The Consultant's procedures used to implement the requirements of this sub-specification shall be subject to the approval of the City. In the event of disapproval, the Consultant is solely responsible for devising new procedures that meet with the explicit approval of the City.

The quality control system shall ensure that adequate control of quality is maintained throughout all areas of contract performance, including, as applicable, the receipt, identification, stocking, and issuance of material; the entire physical process of manufacture, packaging, shipping, storage, installation, and maintenance; and processes of software development including design structure, coding, testing, integration, and implementation.

All equipment, supplies, and services under the contract, whether manufactured or performed at the Consultant's facility or at any other source, shall be subject to control at such points as necessary to ensure conformity with the specifications and contractual requirements. The proposed solution shall provide for the prevention and ready detection of discrepancies and for timely and positive corrective action. The Consultant must make objective evidence of quality performance readily available to the City.

ATTACHMENT II

AGREEMENT FOR CONSULTING SERVICES

THIS AGREEMENT FOR CONSULTING SERVICES (the "Agreement") is made and entered into as of _____ 2019, by and between the CITY OF IRVINE, a municipal corporation ("City"), and _____, a (insert legal entity such as "sole proprietorship" or "California corporation") ("Consultant").

PART I

FUNDAMENTAL TERMS

A. Location of Project: The City of Irvine location(s) as set forth in PART IV, Scope of Services, included herein.

B. Description of Services/Goods to be Provided: Public Safety CAD/RMS Mobile Software Replacement in accordance with PART IV, Scope of Services, included herein (reference RFP 19-1511).

C. Term: Unless terminated earlier as set forth in this Agreement, the services shall commence on June 30, 2019 ("Commencement Date") and shall continue through December 31, 2021.

D. Party Representatives:

D.1. The City designates the following person/officer to act on City's behalf:
Jade Mazzio, email: jmazzio@cityofirvine.org

D.2. The Consultant designates the following person to act on Consultant's behalf:
_____, email: _____

E. Notices: Consultant shall deliver all notices and other writings required to be delivered under this Agreement to City at the address set forth in Part II ("General Provisions"). The City shall deliver all notices and other writings required to be delivered to Consultant at the address set forth following Consultant's signature below.

F. Attachments: This Agreement incorporates by reference the following Attachments to this Agreement:

- | | | |
|------|-----------|--------------------|
| F.1. | Part I: | Fundamental Terms |
| F.2. | Part II: | General Provisions |
| F.3. | Part III: | Special Provisions |
| F.4. | Part IV: | Scope of Services |
| F.5. | Part V: | Budget |

G. Integration: This Agreement represents the entire understanding of City and Consultant as to those matters contained herein. No prior oral or written understanding shall be of any force or effect with regard to those matters covered by this Agreement. This Agreement supersedes and cancels any and all previous negotiations, arrangements, agreements, and understandings, if any, between the parties, and none shall be used to interpret this Agreement.

IN WITNESS WHEREOF, the parties have executed and entered into this Agreement as of the date first set forth above.

CITY OF IRVINE

CONTRACTOR NAME

By: _____
Jimmee Medina
Its: Director of Human Resources
and Innovation

By: _____

Its: _____

By: _____
John A. Russo
Its: City Manager

By: _____

Its: _____

By: _____
Donald P. Wagner
Its: Mayor of the City of Irvine

Attest:

By: _____
Molly McLaughlin
City Clerk

Contractor Information
Address for Notices and Payments:

APPROVED AS TO FORM:
RUTAN & TUCKER, LLP

Jeffrey Melching

Attn:

PART II**GENERAL PROVISIONS****SECTION ONE: SERVICES OF CONSULTANT**

1.1 Scope of Services. In compliance with all terms and conditions of this Agreement, Consultant shall provide the goods and/or services shown on Part IV hereto ("Scope of Services"), which may be referred to herein as the "services" or the "work." If this Agreement is for the provision of goods, supplies, equipment or personal property, the terms "services" and "work" shall include the provision (and, if designated in the Scope of Services, the installation) of such goods, supplies, equipment or personal property.

1.2 Changes and Additions to Scope of Services. City shall have the right at any time during the performance of the services, without invalidating this Agreement, to order extra work beyond that specified in the Scope of Services or make changes by altering, adding to, or deducting from said work. No such work shall be undertaken unless a written order is first given by City to Consultant, incorporating therein any adjustment in (i) the Budget, and/or (ii) the time to perform this Agreement, which adjustments are subject to the written approval of the Consultant. City approval and/or payment for work claimed by Consultant as changed or additional shall not act to prevent City at any time to claim such work is covered by the Scope of Work and should be performed by Consultant without additional consideration due. It is expressly understood by Consultant that the provisions of this Section 1.2 shall not apply to services specifically set forth in the Scope of Services or reasonably contemplated therein. Consultant hereby acknowledges that it accepts the risk that the services to be provided pursuant to the Scope of Services may be more costly or time consuming than Consultant anticipates and that Consultant shall not be entitled to additional compensation therefor.

1.3 Standard of Performance. Consultant agrees that all services shall be performed in a competent, professional, and satisfactory manner in accordance with the standards prevalent in the industry, and that all goods, materials, equipment or personal property included within the services herein shall be of good quality, fit for the purpose intended.

1.4 Performance to Satisfaction of City. Notwithstanding any other provision herein, Consultant agrees to perform all work to the satisfaction of City within the time specified. If City reasonably determines that the work is not satisfactory, City shall have the right to take appropriate action, including but not limited to: (i) meeting with Consultant to review the quality of the work and resolve matters of concern; (ii) requiring Consultant to repeat unsatisfactory work at no additional charge until it is satisfactory; (iii) suspending the delivery of work to Consultant for an indefinite time; (iv) withholding payment; and (v) terminating this Agreement as hereinafter set forth.

1.5 Instructions from City. In the performance of this Agreement, Consultant shall report to and receive instructions from the City's Representative designated in Paragraph D.1 of Part I ("Fundamental Terms") of this Agreement. Tasks or services other than those specifically described in the Scope of Services shall not be performed without the prior written approval of the City's Representative.

1.6 Familiarity with Work. By executing this Agreement, Consultant warrants that Consultant (i) has thoroughly investigated and considered the scope of services to be performed, (ii) has carefully considered how the services should be performed, and (iii) fully understands the facilities, difficulties, and restrictions attending performance of the services under the Agreement. If

the services involve work upon any site, Consultant warrants that Consultant has or will investigate the site and is or will be fully acquainted with the conditions there existing, prior to commencement of services hereunder. Should the Consultant discover any conditions, including any latent or unknown conditions, which will materially affect the performance of the services hereunder, Consultant shall immediately inform the City of such fact in writing and shall not proceed except at Consultant's risk until written instructions are received from the City's Representative.

1.7 Identity of Persons Performing Work.

(A) Consultant represents that it employs or will employ at its own expense all personnel required for the satisfactory performance of any and all tasks and services required hereunder. Any personnel performing the services under this Agreement on behalf of Consultant shall at all times be under Consultant's exclusive direction and control. Consultant shall pay all wages, salaries, and other amounts due such personnel in connection with their performance of services under this Agreement and as required by law.

(B) Consultant represents that the tasks and services required hereunder will be performed by Consultant or under its direct supervision, and that all personnel engaged in such work shall be fully qualified and shall be authorized and permitted under applicable State and local law to perform such tasks and services. Consultant will exclusively determine the means, methods and details of performing the services subject to the requirements of this Agreement.

(C) This Agreement contemplates the personal services of Consultant and Consultant's employees, and it is recognized by the parties hereto that a substantial inducement to City for entering into this Agreement was, and is, the professional reputation and competence of Consultant. Neither this Agreement nor any interest therein may be assigned by Consultant, except upon written consent of City.

1.8 Prohibition Against Subcontracting or Assignment. Consultant shall not contract with any other entity to perform in whole or in part the services required hereunder without the express written approval of City. In addition, neither the Agreement nor any interest herein may be transferred, assigned, conveyed, hypothecated, or encumbered voluntarily or by operation of law, whether for the benefit of creditors or otherwise, without the prior written approval of City. In the event of any unapproved transfer, including any bankruptcy proceeding, City may void the Agreement at City's option in its sole and absolute discretion. No approved transfer shall release any surety of Consultant of any liability hereunder without the express written consent of City.

SECTION TWO: INSURANCE AND INDEMNIFICATION

2.1 Insurance. Without limiting Consultant's indemnification obligations, Consultant shall procure and maintain, at its sole cost and for the duration of this Agreement, insurance coverage as provided below, against all claims for injuries against persons or damages to property which may arise from or in connection with the performance of the work hereunder by Consultant, its agents, representatives, employees, and/or subconsultants. In the event that Consultant subcontracts any portion of the work in compliance with Section 1.8 of this Agreement, the contract between the Consultant and such subconsultant shall require the subconsultant to maintain the same policies of insurance that the consultant is required to maintain pursuant to this Section 2.1.

2.1.1 Insurance Coverage Required. The Insurance obligations under this agreement shall be (1) all the Insurance coverage and/or limits carried by or available to the Consultant; or (2) the minimum Insurance coverage requirements and/or limits shown in

this agreement; whichever is greater. Any insurance proceeds in excess of or broader than the minimum required coverage and/or minimum required limits, which are applicable to a given loss, shall be available to the City. No representation is made that the minimum insurance requirements of this agreement are sufficient to cover the obligations of the Consultant under this agreement.

The policies and amounts of insurance required hereunder shall be as follows:

A. Comprehensive General Liability Insurance which affords coverage at least as broad as Insurance Services Office "occurrence" form CG 00 01 including completed operations and contractual liability, with limits of liability of not less than \$1,000,000 per occurrence and \$2,000,000 annual aggregate for liability arising out of Consultant's performance of this Agreement. The limits shall be provided by either a single primary policy or combination of policies. If limits are provided with excess and/or umbrella coverage the limits combined with the primary will equal the minimum limits set forth above. If written with an aggregate, the aggregate shall be double the each occurrence limit. Such insurance shall be endorsed to:

- (1) Name the City of Irvine and its employees, representatives, officers and agents (collectively hereinafter "City and City Personnel") as additional insured for claims arising out of Consultant's performance of this Agreement.
- (2) Provide that the insurance is primary and non-contributing with any other valid and collectible insurance or self-insurance available to City.

A statement on an insurance certificate will not be accepted in lieu of the actual endorsement.

B. Automobile Liability Insurance with a limit of liability of not less than \$1,000,000 each occurrence and \$1,000,000 annual aggregate. The limits shall be provided by either a single primary policy or combination of policies. If limits are provided with excess and/or umbrella coverage the limits combined with the primary will equal the minimum limits set above. Such insurance shall include coverage for all "owned," "hired" and "non-owned" vehicles, or coverage for "any auto." Such insurance shall be endorsed to:

- (1) Name the City of Irvine and its employees, representatives, officers and agents as additional insured for claims arising out of Consultant's performance of this Agreement.
- (2) Provide that the insurance is primary and non-contributing with any other valid and collectible insurance or self-insurance available to City.

A statement on an insurance certificate will not be accepted in lieu of the actual endorsement.

C. Workers' Compensation Insurance in accordance with the Labor Code of California and covering all employees of the Consultant providing any service in the performance of this agreement. Such insurance shall be endorsed to:

- (1) Waive the insurer's right of Subrogation against the City and City Personnel.

A statement on an insurance certificate will not be accepted in lieu of the actual endorsement unless your insurance carrier is the State of California Insurance Fund (SCIF) and the endorsement numbers 2570 and 2065 are referenced on the certificate of insurance.

Consultant's completion of the form attached hereto as Exhibit 1 shall be a condition precedent to Consultant's rights under this Agreement. Should Consultant certify, pursuant to Exhibit 1, that, in the performance of the work under this Agreement, it shall not employ any person in any manner so as to become subject to the workers' compensation laws of California, Consultant shall nonetheless maintain responsibility for requiring that any subconsultants performing work under this Agreement have and maintain workers' compensation insurance, as required by Section 3700 of the Labor Code, for the work performed under this Agreement.

D. Professional Liability Insurance with minimum limits of \$1,000,000 each claim. Covered professional services shall include all work performed under this Agreement and delete any exclusion that may potentially affect the work to be performed.

E. If the consultant maintains broader coverage and/or higher limits than the minimums shown above, the City requires and shall be entitled to the broader coverage and/or higher limits maintained by the consultant.

F. Evidence of Insurance: Consultant shall provide to City a Certificate(s) of Insurance evidencing such coverage together with copies of the required policy endorsements no later than five (5) business days prior to commencement of service and at least fifteen (15) business days prior to the expiration of any policy. Coverage shall not be suspended, voided, cancelled, reduced in coverage or in limits, non-renewed, or materially changed for any reason, without thirty (30) days prior written notice thereof given by the insurer to City by U.S. mail, or by personal delivery, except for nonpayment of premiums, in which case ten (10) days prior notice shall be provided.

The City project title or description MUST be included in the "Description of Operations" box on the certificate.

The City's insurance certificate tracking services provider, Exigis, LLC, will send Consultant an email message providing instructions for submitting insurance certificates and endorsements.

Certificate Holder:

City of Irvine, California
c/o: Exigis LLC
PO Box 4668 ECM #35050
New York, NY 10168-4668

G. Endorsements: A statement on an insurance certificate will not be accepted in lieu of the actual endorsement. Insurance policies shall not be in compliance if they include any limiting provision or endorsement that has not been submitted to the City for approval.

Additional Insured Endorsements shall not:

1. Be limited to "Ongoing Operations"
2. Exclude "Contractual Liability"

3. Restrict coverage to the "Sole" liability of Consultant
4. Contain any other exclusion contrary to the Agreement.

H. Any Deductible in Excess of \$100,000 and/or Self-Insured Retentions must be approved in writing by the City.

I. Acceptability of Insurers. Each policy shall be from a company with current A.M. Best's rating of A- VII or higher and authorized to do business in the State of California, or otherwise allowed to place insurance through surplus lines brokers under applicable provisions of the California Insurance Code or any federal law. Any other rating must be approved in writing by the City.

J. Insurance of Subconsultants. Consultant shall be responsible for causing Subconsultants to maintain the same types and limits of coverage in compliance with this Agreement, including naming the City as an additional insured to the Subconsultant's policies.

2.2 Indemnification. Consultant shall indemnify, defend, and hold City and City Personnel harmless from and against any and all actions, suits, claims, demands, judgments, attorney's fees, costs, damages to persons or property, losses, penalties, obligations, expenses or liabilities (herein "claims" or "liabilities") that may be asserted or claimed by any person or entity arising out of the willful or negligent acts, errors or omissions of Consultant, its employees, agents, representatives or subconsultants which directly or indirectly relate to the work being performed or services being provided under this Agreement, whether or not there is concurrent active or passive negligence on the part of City and/or City Personnel, but excluding such claims or liabilities arising from the sole active negligence or willful misconduct of City or City Personnel in connection therewith:

2.2.1 Consultant shall defend any action or actions filed in connection with any such claims or liabilities, and shall pay all costs and expenses, including attorney's fees incurred in connection therewith.

2.2.2 Consultant shall promptly pay any judgment rendered against City or any City Personnel for any such claims or liabilities.

2.2.3 In the event City and/or any City Personnel is made a party to any action or proceeding filed or prosecuted for any such damages or other claims arising out of or in connection with the work being performed or services being provided under this Agreement, Consultant shall pay to City any and all costs and expenses incurred by City or City Personnel in such action or proceeding, together with reasonable attorney's fees and expert witness fees.

These Indemnification provisions are independent of, and shall not in any way be limited by, the Insurance Requirements of this Agreement. City approval of the insurance contracts required by this Agreement does not in any way relieve the Consultant from liability under this section.

SECTION THREE: LEGAL RELATIONS AND RESPONSIBILITIES

3.1 Compliance with Laws. Consultant shall keep itself fully informed of all existing and future state and federal laws and all county and city ordinances and regulations which in any manner affect those employed by it or in any way affect the performance of services pursuant to this Agreement. Consultant shall at all times observe and comply with all such laws, ordinances,

and regulations and shall be responsible for the compliance of all work and services performed by or on behalf of Consultant. When applicable, Consultant shall not pay less than the prevailing wage, which rate is determined by the Director of Industrial Relations of the State of California.

3.2 Licenses, Permits, Fees and Assessments. Consultant shall obtain at its sole cost and expense all licenses, permits, and approvals that may be required by law for the performance of the services required by this Agreement. Consultant shall have the sole obligation to pay any fees, assessments, and taxes, plus applicable penalties and interest, which may be imposed by law and arise from or are necessary for Consultant's performance of the services required by this Agreement, and shall indemnify, defend, and hold harmless City against any such fees, assessments, taxes, penalties, or interest levied, assessed, or imposed against City thereunder.

3.3 Covenant against Discrimination. Consultant covenants for itself, its heirs, executors, assigns, and all persons claiming under or through it, that there shall be no discrimination against any person on account of race, religious creed, color, national origin, ancestry, physical disability, mental disability, medical condition, genetic information, marital status, sex, gender, gender identity, gender expression, age, sexual orientation, or military and veteran status of any person, in the performance of this Agreement. Consultant further covenants and agrees to comply with the terms of the Americans with Disabilities Act of 1990 (42 U.S.C. §12101 et seq.) as the same may be amended from time to time.

3.4 Independent Consultant. Consultant shall perform all services required herein as an independent consultant of City and shall remain at all times as to City a wholly independent consultant. City shall not in any way or for any purpose become or be deemed to be a partner of Consultant in its business or otherwise, or a joint venturer, or a member of any joint enterprise with Consultant. Consultant shall not at any time or in any manner represent that it or any of its agents or employees are agents or employees of City. Neither Consultant nor any of Consultant's employees shall, at any time, or in any way, be entitled to any sick leave, vacation, retirement, or other fringe benefits from the City; and neither Consultant nor any of its employees shall be paid by City time and one-half for working in excess of forty (40) hours in any one week. City is under no obligation to withhold State and Federal tax deductions from Consultant's compensation. Neither Consultant nor any of Consultant's employees shall be included in the competitive service, have any property right to any position, or any of the rights an employee may have in the event of termination of this Agreement.

3.5 Covenant against Contingent Fees. Consultant warrants that it has not employed or retained any company or person other than a bona fide employee working for Consultant, to solicit or secure this Agreement and that it has not paid or agreed to pay any company or person any fee, commission, percentage, brokerage fee, gift, or any other consideration contingent upon, or resulting from, the award or making of this Agreement. For breach or violation of this warranty, City shall have the right to annul this Agreement without liability or, in its discretion, to deduct from the Agreement price or consideration, or otherwise recover, the full amount of such fee, commission, percentage, brokerage fee, gift or contingent fee.

3.6 Use of Patented Materials. Consultant shall assume all costs arising from the use of patented or copyrighted materials, including but not limited to equipment, devices, processes, and software programs, used or incorporated in the services or work performed by Consultant under this Agreement. Consultant shall indemnify, defend, and save the City harmless from any and all suits, actions or proceedings of every nature for or on account of the use of any patented or copyrighted materials consistent with Section 2.2 herein.

3.7 Proprietary Information. All proprietary information developed specifically for City by Consultant in connection with, or resulting from, this Agreement, including but not limited to inventions, discoveries, improvements, copyrights, patents, maps, reports, textual material, or software programs, but not including Consultant's underlying materials, software, or know-how, shall be the sole and exclusive property of City, and are confidential and shall not be made available to any person or entity without the prior written approval of City. Consultant agrees that the compensation to be paid pursuant to this Agreement includes adequate and sufficient compensation for any proprietary information developed in connection with or resulting from the performance of Consultant's services under this Agreement. Consultant further understands and agrees that full disclosure of all proprietary information developed in connection with, or resulting from, the performance of services by Consultant under this Agreement shall be made to City, and that Consultant shall do all things necessary and proper to perfect and maintain ownership of such proprietary information by City.

3.8 Retention of Funds. Consultant hereby authorizes City to deduct from any amount payable to Consultant (whether arising out of this Agreement or otherwise) any amounts the payment of which may be in dispute hereunder or which are necessary to compensate City for any losses, costs, liabilities, or damages suffered by City, and all amounts for which City may be liable to third parties, by reason of Consultant's negligent acts, errors, or omissions, or willful misconduct, in performing or failing to perform Consultant's obligations under this Agreement. City in its sole and absolute discretion, may withhold from any payment due Consultant, without liability for interest, an amount sufficient to cover such claim or any resulting lien. The failure of City to exercise such right to deduct or withhold shall not act as a waiver of Consultant's obligation to pay City any sums Consultant owes City.

3.9 Termination by City. City reserves the right to terminate this Agreement at any time, with or without cause, upon written notice to Consultant. Upon receipt of any notice of termination from City, Consultant shall immediately cease all services hereunder except such as may be specifically approved in writing by City. Consultant shall be entitled to compensation for all services rendered prior to receipt of City's notice of termination and for any services authorized in writing by City thereafter. If termination is due to the failure of Consultant to fulfill its obligations under this Agreement, City may take over the work and prosecute the same to completion by contract or otherwise, and Consultant shall be liable to the extent that the total cost for completion of the services required hereunder, including costs incurred by City in retaining a replacement consultant and similar expenses, exceeds the Budget.

3.10 Right to Stop Work; Termination by Consultant. Consultant shall have the right to stop work and terminate only if City fails to timely make a payment required under the terms of the Budget. Consultant shall provide City thirty (30) day prior written notice of such claimed payment owed and City shall have an opportunity to remedy any such claimed breach during such time with no legal consequence to City. Consultant shall immediately cease all services hereunder following the thirty (30) day notice, except such services as may be specifically approved in writing by City. Consultant shall be entitled to compensation for all services rendered prior to termination and for any services authorized in writing by City thereafter. If Consultant terminates this Agreement because of an error, omission, or a fault of Consultant, or Consultant's willful misconduct, the terms of Section 3.9 relating to City's right to take over and finish the work and Consultant's liability shall apply.

3.11 Waiver. No delay or omission in the exercise of any right or remedy by a nondefaulting party with respect to any default shall impair such right or remedy or be construed as a waiver. A party's consent to or approval of any act by the other party requiring the party's consent

or approval shall not be deemed to waive or render unnecessary consent to or approval of any subsequent act. A waiver by either party of any default must be in writing.

3.12 Legal Actions. Legal actions concerning any dispute, claim, or matter arising out of or in relation to this Agreement shall be instituted and maintained in the Superior Courts of the State of California in the County of Orange, or in any other appropriate court with jurisdiction in such County, and Consultant agrees to submit to the personal jurisdiction of such court.

3.13 Rights and Remedies are Cumulative. Except as may be expressly set forth in this Agreement, the rights and remedies of the parties are cumulative and the exercise by either party of one or more of such rights or remedies or other rights or remedies as may be permitted by law or in equity shall not preclude the exercise by such party, at the same or different times, of any other rights or remedies to which such party may be entitled.

3.14 Attorneys' Fees. In any action between the parties hereto seeking enforcement of any of the terms or provisions of this Agreement or in connection with the performance of the work hereunder, the party prevailing in the final judgment in such action or proceeding, in addition to any other relief which may be granted, shall be entitled to have and recover from the other party its reasonable costs and expenses, including, but not limited to, reasonable attorney's fees, expert witness fees, and courts costs. If either party to this Agreement is required to initiate or defend litigation with a third party because of the violation of any term or provision of this Agreement by the other party, then the party so litigating shall be entitled to its reasonable attorney's fees and costs from the other party to this Agreement.

3.15 Force Majeure. The time period specified in this Agreement for performance of services shall be extended because of any delays due to unforeseeable causes beyond the control and without the fault or negligence of City or Consultant, including, but not restricted to, acts of nature or of the public enemy, unusually severe weather, fires, earthquakes, floods, epidemics, quarantine restrictions, riots, strikes, freight embargoes, wars, litigation, and/or acts of any governmental agency, including City, if the delaying party shall within ten (10) days of the commencement of such delay notify the other party in writing of the causes of the delay. If Consultant is the delaying party, City shall ascertain the facts and the extent of delay, and extend the time for performing the services for the period of the enforced delay when and if in the judgment of City such delay is justified. City's determination shall be final and conclusive upon the parties to this Agreement. In no event shall Consultant be entitled to recover damages against City for any delay in the performance of this Agreement, however caused. Consultant's sole remedy shall be extension of this Agreement pursuant to this Section 3.15.

3.16 Non-liability of City Officers and Employees. No officer, official, employee, agent, representative, or volunteer of City shall be personally liable to Consultant, or any successor in interest, in the event of any default or breach by City, or for any amount which may become due to Consultant or its successor, or for breach of any obligation of the terms of this Agreement.

3.17 Conflicts of Interest.

A. No officer, official, employee, agent, representative or volunteer of City shall have any financial interest, direct or indirect, in this Agreement, or participate in any decision relating to this Agreement that affects his or her financial interest or the financial interest of any corporation, partnership, association or other entity in which he or she is interested, in violation of any federal, state or city statute, ordinance or regulation. Consultant shall not employ any such person while this Agreement is in effect.

B. Consultant represents, warrants and covenants that he, she or it presently has no interest, direct or indirect, which would interfere with or impair in any manner or degree the performance of Consultant's obligations and responsibilities under this Agreement. Consultant further agrees that while this Agreement is in effect, Consultant shall not acquire or otherwise obtain any interest, direct or indirect, that would interfere with or impair in any manner or degree the performance of Consultant's obligations and responsibilities under this Agreement.

C. Consultant acknowledges that pursuant to the provisions of the Political Reform Act (Government Code section 87100 *et seq.*), City may determine Consultant to be a "Consultant" as that term is defined by the Act. In the event City makes such a determination, Consultant agrees to complete and file a "Statement of Economic Interest" with the City Clerk to disclose such financial interests as required by City. In such event, Consultant further agrees to require any other person doing work under this Agreement to complete and file a "Statement of Economic Interest" to disclose such other person's financial interests as required by City.

3.18 Consultant Ethics. Consultant represents and warrants that it has not provided or promised to provide any gift or other consideration, directly or indirectly, to any officer, employee, or agent of City to obtain City's approval of this Agreement. Consultant shall not, at any time, have any financial interest in this Agreement or the project that is the subject of this Agreement other than the compensation to be paid to Consultant as set forth in this Agreement. In the event the work and/or services to be performed hereunder relate to a project and/or application under consideration by or on file with the City, (i) Consultant shall not possess or maintain any business relationship with the applicant or any other person or entity which Consultant knows to have a personal stake in said project and/or application, (ii) other than performing its work and/or services to City in accordance with this Agreement Consultant shall not advocate either for or against said project and/or application, and (iii) Consultant shall immediately notify City in the event Consultant determines that Consultant has or acquires any such business relationship with the applicant or other person or entity which has a personal stake in said project and/or application. The provisions in this Section shall be applicable to all of Consultant's officers, directors, employees, and agents, and shall survive the termination of this Agreement.

3.19 Compliance with California Unemployment Insurance Code Section 1088.8. If Consultant is a Sole Proprietor, then prior to signing the Agreement, Consultant shall provide to the City a completed and signed Form W-9, Request for Taxpayer Identification Number and Certification. Consultant understands that pursuant to California Unemployment Insurance Code Section 1088.8, the City will report the information from Form W-9 to the State of California Employment Development Department, and that the information may be used for the purposes of establishing, modifying, or enforcing child support obligations, including collections, or reported to the Franchise Tax Board for tax enforcement purposes.

3.20 CalPERS Annuitants. If Consultant is a California Public Employees' Retirement System ("CalPERS") annuitant, Consultant must provide the City with written notification of such fact a minimum of 14 calendar days prior to commencement of services under this Agreement. Failure to provide such notification may result in termination of the Agreement, and any penalties or other costs relating thereto shall be borne by Consultant. If this Agreement remains in place, Consultant shall execute any amendment(s) to this Agreement requested by the City in order to comply with all laws and regulations applicable to CalPERS annuitants.

SECTION FOUR: MISCELLANEOUS PROVISIONS

4.1 Records and Reports. The City Manager of the City of Irvine or his/her designee reserves the right to perform such audits, performance reviews, and other evaluations (collectively 'audit') that relate to or concern this Agreement at any time. Consultant agrees to participate and cooperate in up to five (5) hours of meetings and interviews (at no additional cost to City), if the same are requested by the City in connection with such an audit. Further, provided that the City pays Consultant's commercially reasonable hourly rate for services, Consultant agrees to participate and cooperate in such additional meetings and interviews (in excess of five (5) hours), if the same are requested by the City in connection with such an audit. Upon request by City, Consultant shall prepare and submit to City any reports concerning Consultant's performance of the services rendered under this Agreement. City shall have access, with 72 hours advance written notice delivered to Consultant, to the books and records of Consultant related to Consultant's performance of this Agreement in the event any audit is required. All drawings, documents, and other materials prepared by Consultant in the performance of this Agreement (i) shall be the property of City and shall be delivered at no cost to City upon request of City or upon the termination of this Agreement, and (ii) shall not be made available to any individual or entity without prior written approval of City. The obligations of this Section 4.1 shall survive the expiration (or earlier termination) of this Agreement for a period of three (3) years. During said three (3) year period, Consultant shall keep and maintain all records and reports related to this Agreement, and City shall have access to such records in the event any audit is required.

4.2 Notices. Unless otherwise provided herein, all notices required to be delivered under this Agreement or under applicable law shall be personally delivered, or delivered by United States mail, prepaid, certified, return receipt requested, or by reputable document delivery service that provides a receipt showing date and time of delivery. Notices personally delivered or delivered by a document delivery service shall be effective upon receipt. Notices delivered by mail shall be effective at 5:00 p.m. on the second calendar day following dispatch. Notices to the City shall be delivered to the following address, to the attention of the City Representative set forth in Paragraph D.1 of the Fundamental Terms of this Agreement:

<u>To City:</u>	City of Irvine One Civic Center Plaza (92606) (Hand Deliveries) P. O. Box 19575 Irvine, CA 92623-9575
-----------------	--

Notices to Consultant shall be delivered to the address set forth below Consultant's signature on Part I of this Agreement, to the attention of Consultant's Representative set forth in Paragraph D.2 of the Fundamental Terms of this Agreement. Changes in the address to be used for receipt of notices shall be effected in accordance with this Section 4.2.

4.3 Construction and Amendment. The terms of this Agreement shall be construed in accordance with the meaning of the language used and shall not be construed for or against either party by reason of the authorship of this Agreement or any other rule of construction which might otherwise apply. The headings of sections and paragraphs of this Agreement are for convenience or reference only, and shall not be construed to limit or extend the meaning of the terms, covenants and conditions of this Agreement. This Agreement may only be amended by the mutual consent of the parties by an instrument in writing.

4.4 Severability. Each provision of this Agreement shall be severable from the whole. If any provision of this Agreement shall be found contrary to law, the remainder of this Agreement shall continue in full force.

4.5 Authority. The person(s) executing this Agreement on behalf of the parties hereto warrant that (i) such party is duly organized and existing, (ii) they are duly authorized to execute and deliver this Agreement on behalf of said party, (iii) by so executing this Agreement, such party is formally bound to the provisions of this Agreement, and (iv) the entering into this Agreement does not violate any provision of any other Agreement to which said party is bound.

4.6 Special Provisions. Any additional or supplementary provisions or modifications or alterations of these General Provisions shall be set forth in Part III of this Agreement ("Special Provisions").

4.7 Precedence. In the event of any discrepancy between Part I ("Fundamental Terms"), Part II ("General Provisions"), Part III ("Special Provisions"), Part IV ("Scope of Services"), and/or Part V ("Budget") of this Agreement, the order of precedence shall be as follows.

Part III
Part II
Part IV
Part V
Part I

PART III

SPECIAL PROVISIONS

- 1) **Business License Requirement.** Consultants who provide services for the City of Irvine within the city limits of Irvine shall obtain, within five (5) days of executing this Agreement and prior to commencing any work herein, a City of Irvine business license and shall maintain a current business license throughout the term of this Agreement.
- 2) **Insurance Requirements.** PART II GENERAL PROVISIONS, Section 2.1.1 – B Automobile Liability Insurance and Section 2.1.1 - D. Professional Liability Insurance, are deleted in their entirety.
- 3) **Live Scan Fingerprinting Requirements.** Prior to commencing services, Consultants are required to successfully pass a Department of Justice fingerprinting background check (“Live Scan”) performed by a certified fingerprinting service provider or at the City of Irvine Police Department. The Consultant shall be responsible for obtaining the Live Scan for its staff and shall bear the cost thereof. The agency completing the fingerprints must provide the City of Irvine Human Resources with the background check results and subsequent records for review. Consultants must obtain a Consultant’s badge issued by the City of Irvine Human Resources prior to performing work.

PART IV
SCOPE OF SERVICES

**Services shall be performed as set forth below and in accordance with ATTACHMENT I.
(To be inserted after contract award.)**

PART V

BUDGET

Pricing shall be as set forth below and in accordance with ATTACHMENT II. (To be inserted after contract award.)

Included in the total compensation are all ordinary and overhead expenses incurred by Consultant and its agents and employees, including meetings with City representatives, and incidental costs incurred in performing under this Agreement. The total compensation for the Scope of Services set forth herein **shall not exceed \$ _____ annually**, including all amounts payable to Consultant for its overhead, payroll, profit, and all costs of whatever nature, including without limitation all costs for subcontracts, materials, equipment, supplies, and costs arising from or due to termination of this Agreement.

No work shall be performed in connection with this Agreement until the receipt of a signed City of Irvine Purchase Order; and no work shall be performed with a value in excess of the Purchase Order amount as the City has not authorized nor is it obligated to pay Consultant any such excess amount.

In the event Consultant anticipates the potential need to perform services beyond those set forth herein where additional funding may be needed, Consultant shall notify City in writing allowing sufficient time for City to consider further action.

Payment for services will be made monthly on invoices deemed satisfactory to the City, with payment terms of net 30 days upon receipt of invoice. Consultant shall submit invoices within fifteen (15) days from the end of each month in which services have been provided. Consultant shall provide invoices with sufficient detail to ensure compliance with pricing as set forth in this Agreement. The information required may include: date(s) of work, hours of work, hourly rate(s), and material costs.

The Purchase Order number must be included on all invoices, along with the City Representative's name. Failure to include this information on the invoice shall result in the return of the unpaid invoice.

Consultants should submit invoices electronically to: **invoicesubmittal@cityofirvine.org**

Payment by City under this Agreement shall not be deemed as a waiver of the City's right to claim at a later point that such payment was not due under the terms of this Agreement.

Pricing shall remain firm for the entire first term of the Agreement. Thereafter, any proposed pricing adjustment for follow-on renewal periods shall be submitted to the City Representative in writing at least ninety (90) days prior to the new Agreement term. The City reserves the right to negotiate any proposed pricing adjustment not to exceed the Bureau of Labor Statistics Consumer Price Index (CPI) data as follows: Los Angeles-Long Beach-Anaheim, CA; All Urban Consumers; Not Seasonally Adjusted; annualized change comparing the most recent month's reported data to the same month of the prior year. (This information may be found on the U.S. Department of Labor's website at www.bls.gov.)

Exhibit 1

WORKERS' COMPENSATION INSURANCE CERTIFICATION

Consulting Services Description: Public Safety CAD/RMS Mobile Software Replacement

WORKERS' COMPENSATION DECLARATION

I hereby affirm under penalty of perjury one of the following declarations:

(CHECK ONE APPLICABLE BOX BELOW)

I have and will maintain workers' compensation insurance, as required by Section 3700 of the Labor Code, for the performance of the work to be performed under this Agreement and shall submit insurance certificates evidencing such coverage as set forth herein.

I certify that, in the performance of the work under this Agreement, **I shall not employ any person** in any manner so as to become subject to the workers' compensation laws of California, and I hereby agree to indemnify, defend, and hold harmless the City of Irvine and all of its officials, employees, and agents from and against any and all claims, liabilities, and losses relating to personal injury or death, economic losses, and property damage arising out of my failure to provide such worker's compensation insurance. I further agree that, **if I should become subject to the workers' compensation provisions of Section 3700 of the Labor Code, I shall forthwith comply with those provisions and immediately furnish insurance certificates** evidencing such coverage as set forth herein.

WARNING: FAILURE TO SECURE WORKERS' COMPENSATION COVERAGE IS UNLAWFUL, AND SHALL SUBJECT AN EMPLOYER TO CRIMINAL PENALTIES AND CIVIL FINES UP TO ONE HUNDRED THOUSAND DOLLARS (\$100,000), IN ADDITION TO THE COST OF COMPENSATION, DAMAGES AS PROVIDED FOR IN SECTION 3706 OF THE LABOR CODE, INTEREST, AND ATTORNEY'S FEES.

Dated:	
Contracting Firm:	
Signature:	
Title:	
Address:	

ATTACHMENT III

PRICING PROPOSAL MATRIX (See attached Excel Spreadsheet)

ATTACHMENT IV

CITY TECHNOLOGY STANDARDS

The City maintains a segmented Public Safety Network (“PSN”) operated by the Information Technology (“IT”) Department. The IT Department has established general standards and best practices for the components that make up the various systems deployed with Public Safety as follows;

Network Environment: A segmented public safety network is maintained and operated by the IT Department. Each agency within the public safety network is further isolated into VLAN’s into two functional disciplines, Police and Communications, to ensure access to protect data is secure. I.e., CJIS data vs HIPAA data, etc.

The segments and VLAN’s are isolated behind SonicWALL Firewalls (“FW”). The PSN has interconnections with other public safety agencies locally and at the County and State via many different mediums including VPN, Point-to-Point and LAN-to-LAN connections. All layer three switches are VDX 6740/7750 and ICX 6610 series Enterprise-Class Brocade Switches. All firewalls are SonicWALL SRA Series 4600 firewalls.

Network Access and Security: The City has deployed as its standard, Microsoft Enterprise Endpoint Protection, to impose two standards that encompass security on desktop computers, mobile computers and servers. Desktop and mobile computers require Microsoft’s Windows Defender Security Center software to be loaded. This software acts as the anti-virus and malware software. Also required is Windows Defender Security Center on all servers that serve information to computers such as a file server.

Users are authenticated on both stationary desktop computers and mobile computers by Windows Active Directory. For stationary desktop computers, user’s login using the standard Windows login and once the user’s credentials are verified; the user arrives at the Windows desktop.

MDC traffic is using Windows 10 OS firewall and encrypted by NetMotion using 256 AES encryption. Generated traffic is sent across the commercial wireless carrier (Verizon and AT&T) to the PSN through a dedicated circuit into Cisco routers. The routers are then connected to the CAD VLAN segment which has access to the Cal DOJ CLETS via a Point-To-Point connection. The CAD system has access to the same VLAN via the COM router server.

The Cal DoJ CLETS information is accessed via the CAD server by an MDC via the CAD client. NetMotion client is used to encrypt/decrypt the communications between the MDC and CAD VLAN. No CLETS data is stored on the MDC hard drives.

MDC, Tablet and Smartphone users will utilize NetMotion Mobility Client to secure a VPN connection via the agency’s wireless network provider, Verizon and AT&T, with the agency’s secured network for accessing the CLETS. NetMotion works in conjunction with a CJIS compliant 2-factor authentication provider, Rapid Identity (formerly 2FA) using RFID cards in

combination with NetMotion to accomplish “something you know”; username and password, with “something you have”; an access card.

There is a tertiary authentication that occurs between the MDC, AD, Microsoft Certificate Authority (“CA”), and Microsoft RADIUS. This authentication is called machine authentication. After the computer joins the Domain, the computer object in Active Directory is moved to the appropriate Organizational Unit (“OU”). The object then authenticates against RADIUS and the CA issues a valid certificate. This entrusts that the computer that has VPN access through NetMotion identifies as an authorized computer to then access network resources.

Time Synchronization: The City synchronizes system time to an NTP server. Windows utilizes a time service called ‘Windows Time’, which is automatically installed in the service list. The program executable is ‘w32time.exe’. The service is installed and enabled by default during installation.

Windows Domain Networking is deployed, and only the Primary Domain Controller (PDC) synchronizes with the time reference. All other servers and workstations in the domain sync to the PDC using Windows proprietary protocol. The default installation procedure automatically configures workstations and servers to sync to the controlling PDC. Only the PDC needs to be configured to synchronize to an external time reference. The City currently sync to the following url: north-america.pool.ntp.org.

All servers, workstations, MDCs and Brocade/Cisco network equipment are setup to sync with the City’s PDC. Mobile devices like phones and tablets use the cellular provider network to sync their clocks.

NetMotion Mobility: By F-Secure Corporation (NIST Cert# 237, 441, & 493, FIPS 140-2 Certified) provides the secure VPN tunnel with end-to-end security standards-based encryption to FIPS 140-2 validated AES encryption.

Software Updates: The IT Department utilizes Microsoft’s System Center Configuration Manager to deploy software to each desktop computer, mobile computer and server on the network. IT uses the same software to provide operating system software updates to these resources as well. IT defines this process as “Patch Tuesday” in which updates are sent out to affected systems that receive the updates once a month. When a threat is recognized prior to the standard Patch Tuesday interval, IT staff triggers the system to perform the update at that time, rather than waiting for the next Patch Tuesday.

Desktop Hardware and Operating System Software: The City standardizes with Dell Optiplex Desktop computers with Windows 7 Pro-64-bit, Windows 8.1, and Windows 10. The City is phasing out older Lenovo desktop computers. The PC should have a minimum Intel Core i5 3.2GHz processor, 8 GB of RAM, a 500 GB HDD and a DVDRW. Each computer is equipped with Dell/Lenovo monitors varying from 17 inch to 24 inch models.

The City replaces desktop computers on a 5-year cycle and the monitors on an as needed basis. For the purpose of the CAD, RMS and Mobile Replacement Project, the City has held off replacing the hardware within the Communication Center until a Consultant has been selected and specific requirements are determined.

Server Hardware and Operating System Software: The City standardizes with Dell FX/FC hosts and Hyper-V software for the virtual servers. The servers' operating system ranges from Microsoft Windows 2008 to 2016.

The City replaces physical servers on a 7-year cycle. For the purpose of the CAD, RMS and Mobile Replacement Project, the City has held off replacing the hardware for CAD servers and ancillary interface servers until a Consultant has been selected and specific requirements are determined.

Mobile Hardware and Operating System Software: The standard hardware is the Panasonic CF-33 Rugged Tablet; 12in Display, 5MP Camera, Intel i5-6300U 2.4GHz Processor, 16GB RAM, 500GB SSD, 1200 NITs Touchscreen Display, Dual batteries, 5MP camera, 802.11AC Wireless, Bluetooth, TPM, GPS built in receiver, 4G.LTE Broadband (Multi Carrier). Each tablet is configured to run Windows 10 enterprise 64-bit. BitLocker provides full disk encryption.

The City replaces mobile computers on a 7-year cycle. For the purpose of the CAD, RMS and Mobile Replacement Project, the City requires the Consultant to ensure their mobile applications are capable of being installed and perform as designed without any degradation.

Mobile Smartphone's: The City standardizes on Apple iPhone 7x and 8x with an iOS operating system.

Mobile Device Management ("MDM"): The City utilizes Microsoft Intune cloud-based enterprise mobility management software as an MDM for all mobile devices. Microsoft Intune provides over-the-air centralized management, diagnostics, and monitoring for the mobile devices managed by the City. The City primarily uses Microsoft Intune for Cell Phones. Microsoft Intune monitors each device, showing useful metrics such as client hardware/software information, location of each device, and remote lock and erase devices. The following is the extent to which Microsoft Intune is utilized by the city; push applications to devices, manage user mail exchange credentials, track location of lost devices, and remote lock or wipe of stolen devices.

Back-Up and Recovery Software and Process: The City currently backs up the existing CAD and RMS system using Carbonite's eVault solution. The method of backup is disk to disk to cloud backups. The data is stored on the City's eVault appliances located at the City Hall datacenter and identical copies are sent to the cloud for offsite storage.

City Telephone System: The City has deployed a Voice over Internet Protocol ("VoIP") enterprise telephone system from Cisco. The system utilizes the Cisco Call Manager version 11. The Cisco system is locally hosted on a virtual server and utilizes PRI trunks. The system is SIP compatible and provides legacy analog functionality. The Cisco system supports 500+ phones for the City, to include standard features such as voicemail, call forwarding, conference calling and more.

ATTACHMENT V

CITY GIS STANDARDS

Hardware: GIS maintains a total of six virtual servers. One each staging and production SQL Servers, three web servers (one staging) and one test server.

Software: ESRI based application platform for server and client side access. Inventory includes Server based products: ArcGIS Server Enterprise (Enterprise Geodatabase for MS SQL, ArcGIS Server), and client based desktop ArcGIS. Desktop licensing is concurrent for multi-user access. Twelve concurrent advanced licenses and nine concurrent Basic. Two Single Use.

Data: GIS maintains vector and raster data. Raster data are mainly ortho-images which date back as early as 1976, and images that cover most of the years from 2000 to 2017.

Processes: Irvine GIS currently utilizes ArcMap to publish a variety of Map Services for internal and external use. Public Safety has its own GIS staff who manage the police related data while Irvine GIS manages the City GIS data.

Personnel: The GIS division has 4 full time employees, 1 part-time and 2 interns.

Theme	Description Frame Work Layers	Type	SDE
Parcels	GIS staff maintains the parcel in-house after the parcels are recorded by the County of Orange. Ownership updates provided by Parcel Quest.	Vector	Y
City Boundary	Irvine Incorporation Boundary	Vector	Y
Building Footprint	Building footprints used for addressing, etc.	Vector	Y
Aerial Imagery	Aerial imagery of the City at various resolution from 1976 to 2017	Raster	Y
Street Centerline	Single carriage way road network, with public and private roadways. Also provides address ranges for geo-coding events linked to addresses	Vector	Y
County Centerlines	Street data that falls outside the City Limits in surrounding areas	Vector	Y
Public Safety Areas	These are police areas, beats and ESZ's	Vector	Y
Address points	Points created from the addresses in building footprints	Vector	Y

From: Noelle Smiley
Sent: Wednesday, February 20, 2019 6:16 PM PST
To: Julia Engen; Mike Hamel
Subject: FW: Bid Alert: Invited bid for Public Safety CAD/RMS Mobile System Replacement
Attachments: RFP 19-1511.doc, RFP 19-1511.pdf, ATTACHMENT III - Pricing Proposal Matrix.xlsx

Chief and AC,

Attached is the RFP for the CAD/RMS project.

Noelle

From: Jade Mazzio
Sent: Wednesday, February 20, 2019 6:04 PM
To: Noelle Smiley <nsmiley@cityofirvine.org>
Cc: James Hutchcraft <jhutchcr@cityofirvine.org>
Subject: FW: Bid Alert: Invited bid for Public Safety CAD/RMS Mobile System Replacement

FYI- The CAD/RMS project RFP was posted at 6:00pm tonight. Submittals are due March 22 at 4 p.m.

Jade Mazzio | *Business Services Administrator* | ext. 7111

Attachment "III" - Pricing Workbook

Vendor - Add as many lines in section as required. Make sure all subtotals are calculating and remained link the costs summary section at the bottom.

General Pricing Workbook Instructions

All costs must be identified within this pricing workbook. All proposal components (hardware, software, services, maintenance, misc) must be priced separately and identified as a specific System. Shipping costs and taxes must be identified. Vendor may return a copy of the Pricing Workbook as a PDF, but one submitted copy must remain in its native EXCEL format within the printed file and the electronic copy.

1 - Hardware

Vendor will specify the following information (within the description field below) for all proposed hardware including (but not limited to); Make, Model, Type (tower, desktop, rack server. Etc.), Processor Type, Processor Speed, RAM Type, RAM Amount, RAM Speed, OS Type(s) and Version, Hard Drive Type, Number of Hard Drives, Hard Drive Size, Hard Drive Speed, Optical Drive Type, Make and Model of Graphics Cards, Memory and Speed of Graphics Cards, Number of Graphics Cards required per device, Keyboard Type, Mouse Type, Monitor Type and Size, Number of Monitors per device and Warranty. Pricing shall not be "bundled", all hardware and software will be priced on a "per unit bases".

Vendor will use the sections "Proposal Reference Page Number" and " Proposal Reference Section Number" to identify where in their proposal the relevant information can be located.

Item	Description	System (CAD/RMS/Mobile)	Quantity	Unit Price	Extended Price	Notes
					\$0.00	
					\$0.00	
					\$0.00	
					\$0.00	
					\$0.00	
					\$0.00	
					\$0.00	
					\$0.00	
					\$0.00	
Sub-Total Hardware					\$0.00	

Attachment "III" - Pricing Workbook

Vendor - Add as many lines in section as required. Make sure all subtotals are calculating and remained link the costs summary section at the bottom.

General Pricing Workbook Instructions

All costs must be identified within this pricing workbook. All proposal components (hardware, software, services, maintenance, misc) must be priced separately and identified as a specific System. Shipping costs and taxes must be identified. Vendor may return a copy of the Pricing Workbook as a PDF, but one submitted copy must remain in it's native EXCEL format within the printed file and the electronic copy.

3 - Services

Vendor will specify the following information (within the description field below) for all proposed services, including (but not limited to); Project Management, CAD Configuration and Implementation, Interface Configuration and Implementation, Hardware Installation and Setup, Training, Development of Training Materials and Sub-Contractor Oversight.

Item	Description	System (CAD/RMS/Mobile)	Quantity	Unit Price	Extended Price	Notes
					\$0.00	
					\$0.00	
					\$0.00	
					\$0.00	
					\$0.00	
					\$0.00	
					\$0.00	
					\$0.00	
					\$0.00	
Sub-Total Software					\$0.00	

Attachment "III" - Pricing Workbook

Vendor - Add as many lines in section as required. Make sure all subtotals are calculating and remained link the costs summary section at the bottom.

General Pricing Workbook Instructions

All costs must be identified within this pricing workbook. All proposal components (hardware, software, services, maintenance, misc) must be priced separately and identified as a specific System. Shipping costs and taxes must be identified. Vendor may return a copy of the Pricing Workbook as a PDF, but one submitted copy must remain in its native EXCEL format within the printed file and the electronic copy.

4 - Optional Services

All "Optional Services" identified in the RFP are to be included in this section.

Vendor will use the sections "Proposal Reference Page Number" and " Proposal Reference Section Number" to identify where in their proposal the relevant information can be located

Item	Description	Quantity	Unit Price	Extended Price	Notes
				\$0.00	
				\$0.00	
				\$0.00	
				\$0.00	
				\$0.00	
				\$0.00	
				\$0.00	
				\$0.00	
Sub - Total Optional Se				\$0.00	

5 - Maintenance

Vendor will specify the following information (within the description field below) for all proposed maintenance charges including (but not limited to); Proposed Maintenance Period.

Vendor will use the sections "Proposal Reference Page Number" and " Proposal Reference Section Number" to identify where in their proposal the relevant information can be located

Item	Description	System (CAD/RMS/Mobile)	Quantity	Unit Price	Extended Price	Notes
Year 1					\$0.00	
Year 2					\$0.00	
Year 3					\$0.00	
Year 4					\$0.00	
Year 5					\$0.00	
Sub - Total Maintenance					\$0.00	

6 - Miscellaneous

Vendor will specify the following information (within the description field below) for all proposed miscellaneous charges including (but not limited to); Shipping, Travel, Documentation, Printing..etc.

Vendor will use the sections "Proposal Reference Page Number" and " Proposal Reference Section Number" to identify where in their proposal the relevant information can be located.

Item	Description	System (CAD/RMS/Mobile)	Quantity	Unit Price	Extended Price	Notes
Shipping					\$0.00	
					\$0.00	
					\$0.00	
					\$0.00	

Attachment "III" - Pricing Workbook

Vendor - Add as many lines in section as required. Make sure all subtotals are calculating and remained link the costs summary section at the bottom.

General Pricing Workbook Instructions

All costs must be identified within this pricing workbook. All proposal components (hardware, software, services, maintenance, misc) must be priced separately and identified as a specific System. Shipping costs and taxes must be identified. Vendor may return a copy of the Pricing Workbook as a PDF, but one submitted copy must remain in it's native EXCEL format within the printed file and the electronic copy.

					\$0.00	
Sub - Total Miscellaneous					\$0.00	

Attachment "III" - Pricing Workbook

Vendor - Add as many lines in section as required. Make sure all subtotals are calculating and remained link the costs summary section at the bottom.

General Pricing Workbook Instructions

All costs must be identified within this pricing workbook. All proposal components (hardware, software, services, maintenance, misc) must be priced separately and identified as a specific System. Shipping costs and taxes must be identified. Vendor may return a copy of the Pricing Workbook as a PDF, but one submitted copy must remain in it's native EXCEL format within the printed file and the electronic copy.

7 - Project Cost Summary

Item	Extended Price	Notes
7a - System Costs		
Hardware	\$0.00	
Software	\$0.00	
Services	\$0.00	
Maintenance	\$0.00	
Miscellaneous	\$0.00	
Sub-Total System Costs	\$0.00	
7d - Optional Costs		
Sub-Total Optional Cos	\$0.00	
8 - Project Total Costs		
Total All Costs	\$0.00	



Request for Proposals for Public Safety CAD/RMS Mobile System Replacement

RFP NO. 19-1511

KEY RFP DATES

Issue Date: February 20, 2019

Questions Due: March 11, at 4:00 PM

Submittals Due: March 22, at 4:00 PM

CITYOFIRVINE.ORG/PURCHASING

Address:
1 Civic Center Plaza, Irvine, CA

Email Address:
purchasing@cityofirvine.org

TABLE OF CONTENTS

SECTION

1. PROPOSER RFP CHECKLIST
2. INTRODUCTION
3. QUESTIONS
4. OVERVIEW AND SCOPE OF SERVICES
5. MINIMUM QUALIFICATIONS REQUIRED FOR PROPOSAL SUBMITTAL
6. EVALUATION AND AWARD SCHEDULE
7. TERMS AND CONDITIONS
8. ORGANIZATION OF PROPOSAL
9. SELECTION PROCESS
10. SUBMITTAL INSTRUCTIONS
11. GENERAL INFORMATION

ATTACHMENT I – SCOPE OF SERVICES

ATTACHMENT II - AGREEMENT FOR CONSULTING SERVICES

ATTACHMENT III – PRICING PROPOSAL MATRIX

ATTACHMENT IV – CITY TECHNOLOGY STANDARDS

ATTACHMENT V – CITY GIS SERVICES

1. PROPOSER RFP CHECKLIST

- Download the RFP from the City's website.**
- Read the entire document.** Note critical items such as minimum requirements; supplies/services required; proposal submittal dates and format; contract requirements (e.g. insurance, performance and or reporting, etc.)
- Note the City's contact information.** Firms may only contact those listed in the RFP and in the manner and dates specified in this document. Communication with any other City employee, official, or agent regarding the RFP is prohibited.
- Take advantage of the "Question" period.** Submit your questions to the City's contacts by the due date and time listed on the front page of the RFP document. Questions received by the date, time, and manner specified in the RFP will be answered via an addendum.
- Download, review and acknowledge all addenda** issued for the RFP. All addenda are posted on the City's website as stated in the RFP.
- Follow the format required in the RFP** when preparing your response. Provide point-by-point response to all sections in a clear and concise manner. The proposals are evaluated based solely on the information and material provided in your proposal response.
- Upload your proposal on time to the City's website.** Follow the submittal instructions listed in the RFP. Note the submittal date and time listed on the front page of the RFP and be sure to allow enough time to fully submit your response. No late proposals will be accepted. Staff cannot view submissions prior to RFP closing.

2. INTRODUCTION

Thank you for considering the attached Request for Proposals (RFP). If you are interested in submitting a Proposal, please follow these instructions for submissions:

Only RFP documents downloaded from the City's website (www.cityofirvine.org/purchasing) shall be considered official, as the City must track RFP holders in the event an addendum is issued. Failure to download the RFP document and any addendum from the website will result in disqualification of the proposal.

Proposal Submittal: Please refer to the Submittal Instructions section of this RFP for full details. Proposals submitted by any other method such as hard copy or email will be disqualified.

3. QUESTIONS

Any requests for clarification or other questions concerning this RFP must be submitted in writing and sent via email to the following City contacts no later than the date and time specified on the cover page of this RFP.

Jade Mazzio
Business Services Administrator
jmazzio@cityofirvine.org

Brian D. Brown
Senior Buyer
bbrown@cityofirvine.org

4. OVERVIEW AND SCOPE OF SERVICES

The City of Irvine (hereinafter referred to as the "City") is requesting proposals to establish a contract for Public Safety CAD/RMS Mobile System Replacement, with work to commence on or about June 30, 2019 and cutover to be accomplished by December 31, 2020. Scope of Services in accordance with ATTACHMENT I, attached hereto.

5. MINIMUM QUALIFICATIONS REQUIRED FOR PROPOSAL SUBMITTAL

Firms who fail to meet the minimum qualifications set forth below should not submit a proposal; any such proposal shall be deemed non-responsive and not be considered.

- 1) Minimum three (3) most recent years of experience performing similar services as those detailed in the Scope of Services section of this RFP.

6. EVALUATION AND AWARD SCHEDULE*

Review of proposals to be completed by staff	March 29, 2019
Recommendation to department management that the highest-rated firms be interviewed	Week of April 1
If performed, interviews with highest-rated firms	Week of April 1

Recommendation to Purchasing Agent for contract award	April 2019
Recommendation to Finance Commission for City Council recommendation	April 2019
Recommendation to City Council for contract award in open session	May 2019
Contract award	June 2019

***Schedule subject to change**

7. TERMS AND CONDITIONS

Agreement: The City’s standard Agreement for Consulting Services is included as ATTACHMENT II. Upon award of the contract, it is expected that the successful proposer will accept the Agreement terms and conditions “as is” without modification. (Please refer to Part III Special Provisions of ATTACHMENT II for special requirements relating to these services.) The Agreement for Consulting Services will include an as-yet defined Functionality Matrix. The contents of the Functionality Matrix shall be negotiated between the City and the awarded firm.

Respondent’s Proposal: At the discretion of the City, any or all parts of the respondent’s proposal shall be made a binding part of the selected firm’s contract. The City reserves the right to reject in whole or in part any of the proposals.

Insurance Documents: At the time the contract is awarded, the firm must be able to provide all required insurance documentation to the City’s insurance certificate tracking company as set forth in ATTACHMENT II. If these requirements are not met, the City reserves the right to select the next best qualified firm.

Business License: Consultants who provide services for the City of Irvine within the city limits of Irvine shall obtain, within five (5) days of executing this Agreement and prior to commencing any work herein, a City of Irvine business license and shall maintain a current business license throughout the term of this Agreement.

Failure to Execute the Agreement: Failure to execute the Agreement and furnish the required insurance and business license within the required time period shall be just cause for the rescission of the award. If bonds are also required, failure to furnish sufficient bonds shall cause rescission of the award. If the successful proposer refuses or fails to execute the Agreement, the City may award the Agreement to the next highest-rated firm.

8. ORGANIZATION OF PROPOSAL

If your proposal does not include all of the items below, it may be deemed non-responsive. The proposal will be evaluated by the City and shall include, at a minimum, the following information:

- **BUSINESS INFORMATION**

State the full legal name of your firm, including the state of incorporation if applicable. Include your address, phone number, and email address. State the number of years your firm has been doing business. List the names of principals or officers authorized to bind your firm, including position titles.

- **EXPERIENCE/QUALIFICATIONS INFORMATION**

Provide information concerning your firm's experience and qualifications directly related to the services set forth herein. Provide a detailed description of the capabilities/functionality of your firm's proposed solution as it relates to the City's' needs which are identified in this RFP document. Include specifics regarding your firm's proven ability to deliver innovative technology. Additionally, this section shall define the experience of the Project Manager, other key personnel and sub-consultants assigned to the project. Include resumes for all managers, supervisors, and other key individuals including sub-consultants who will comprise the team. Demonstrate the relevant expertise and experience of each team member. The designated Project Manager shall be the primary contact with the City during the project period. The proposer (prime consultant) must perform a majority of the services. Proposer shall disclose in the project proposal any and all proposed sub-consultant(s), including details regarding which tasks they would perform.

- **PRICING PROPOSAL**

Provide a fee schedule/pricing information for the project, which must include a project lump sum price. The pricing information must also include the cost for annual software maintenance for the first five years after cutover. Additionally, include hourly rates for each category of employee or sub-consultants required to perform the services as set forth in ATTACHMENT I.

The City shall not provide reimbursement for business or travel-related expenses; therefore, such costs must be absorbed in the hourly rate or lump sum fee structure.

- **PROJECT APPROACH / METHODOLOGY**

Explain in detail how your firm would perform the services required as set forth herein. Describe how the proposed modules integrate with each other to yield a fully-integrated solution. Demonstrate how the requirements and provisions of the scope of this project will be implemented. Demonstrate knowledge of the project's objectives and existing conditions/assumptions; identify potential issues/challenges; and describe your firm's approach to minimize disruptions to performance. Present a comprehensive plan for completing the specified work in accordance with the Scope of Services. The response should demonstrate an efficient use of work force, material resources, equipment, and technology to complete the project within the constraints outlined in the Scope of Services. Provide any additional information that communicates how your team intends to achieve the required outcomes and fulfill the responsibilities of the anticipated contract. If appropriate, a project schedule should be included that details each task and sub-task, the timeframe for each and

showing the total number of calendar days from issuance of the Notice to Proceed through 100% completion of the Scope of Services.

- **REFERENCES**

Provide a minimum of three (3) references for work similar to this scope of services that your firm has provided within the last five (5) years. Include a detailed description of the services, the agency or firm names, contact names, phone numbers, email addresses, and dates of services performed.

- **SIGNATURE**

The proposal shall be signed by an official authorized to bind the firm, including his or her printed name and title.

Proposer shall include a statement to the effect that their firm's proposal is valid for ninety (90) days.

9. SELECTION PROCESS

The contract award will be made after selection of one (1) respondent's proposal from among all respondents with implementation of services to follow. However, this RFP does not indicate a commitment by the City to award a contract to any successful respondent. The City intends to evaluate the proposed services based upon the data presented in response to the RFP. The following general selection criteria will be used to evaluate the proposals:

Phase 1:

1. Capability/Functionality of firms proposed product. Relevant experience, innovation and qualifications of firm and designated project management staff, other key personnel, and sub-consultants, if applicable. (50%)
2. Proposal Pricing (20%)
3. Methodology/Project Approach provided (20%)
4. Responsiveness to the Request for Proposals (10%)

Phase 2 for highest-rated firm(s):

- The City reserves the right to conduct interviews with the highest-rated firm or firms. In the event the City does perform an interview process, the additive weighting shall be 50%.

Phase 3 for highest-rated firm(s):

- The City will perform reference checks for similar work completed within the last five (5) years for the highest-rated firm(s), with an additive weighting of 20%.

The City reserves the right to negotiate final pricing with the most qualified/highest-rated firm(s).

The City reserves the right to reject any or all proposals, to waive any informality in any proposal, and to select the proposal that best meets the City's needs.

10. SUBMITTAL INSTRUCTIONS

Proposals submitted by any other method such as hard copy or email will be disqualified.

Submittals:

- **Must be completed** no later than the date and time specified on the cover sheet of this RFP
 - **Failure to completely upload** your document(s) by the deadline shall result in disqualification
- **May be submitted** at any time prior to the deadline
- Submitted proposal **may be withdrawn and resubmitted** at any time prior to the deadline
- **Large files** may take time to upload; so, plan the timing of your submittal accordingly
- **Cannot be viewed** by City staff until the close date and time

Proposals must be submitted electronically as follows:

Proposals must be submitted electronically by visiting the City's website at www.cityofirvine.org/purchasing. **No other form of submission will be accepted.**

1. Click on the "Supplier Registration and Bid Opportunities" link.
2. Next, click the BidsOnline link and then click "Log In."
3. Enter your User Name and Password.
4. Click "Bid Opportunities" and then select the RFP.
5. Click on "Place eBid" and follow the instructions.

Proposal Document Files

The proposal submittal **requires one (1) file**. Use the naming convention as shown below. Do not exceed 20 characters; abbreviate your firm's name if necessary. **Do not use** symbols such as "\$" as your file may not load correctly.

1. Proposal, including pricing: "CompanyName"

Technical Support

In the event you encounter technical difficulties during the uploading process, please contact the Planet Bids, BidsOnline system team as shown below (M-F from 8 am to 5 pm PST):

support@planetbids.com or call (818) 992-1771 ext. 0

11. GENERAL INFORMATION

Costs

Any costs incurred in the preparation of a proposal, presentation to the City, travel in conjunction with such presentations, or samples of items shall be the responsibility of the respondent. The City assumes no responsibility and no liability for costs incurred by respondents prior to issuance of a contract or purchase order.

Additional Information

The proposer shall furnish the City with such additional information as the City may reasonably require.

Property of the City

All data, documents and other products used or developed during performance of the services will remain the property of the City upon completion of the services.

Payment Terms

The City will make payments monthly on approved invoices, with payment terms of net 30 days upon receipt of invoice. Payment for additional work, if any, will be negotiated as required. Final payment will be made after approval and acceptance of the work. The City of Irvine encourages its vendors to choose electronic payment, either through Electronic Fund Transfer (EFT) or ePayables, in order to promote efficiency.

Sincerely,

Brian D. Brown
Senior Buyer

Attachments

ATTACHMENT I

SCOPE OF SERVICES

Consultant shall perform the services as set forth below.

1 SCOPE OF SERVICES

1.1 *Background Information*

1.1.1 The Community

The City of Irvine, located Orange County, CA was formally incorporated in 1971. The City was formed as a master planned community encompassing many residential villages; commercial centers particularly in the technology and semiconductor sectors with many having their national headquarters within the city; religious institutions and educational institutions such as the University of California Irvine, Concordia University, Brandman University, and satellite campuses for numerous colleges, including University of Southern California, California State University Fullerton, University of La Verne and Pepperdine University – just to name a few.

Fire protection in Irvine is provided by the Orange County Fire Authority (“OCFA”) with ambulance service by a private Consultant. Law enforcement is provided by the Irvine Police Department (“IPD”), staffed with approximately 232 sworn officers and 241 non-sworn personnel. The City of Irvine is rated as having the lowest violent crime rate in the nation among larger cities (population over 100,000 to 499,999) based on FBI statistics. Irvine has held the safest city designation for thirteen consecutive years. Irvine’s 2019 population estimated to be at least 285,000 with continued growth over the next two decades that will likely make Irvine the largest city in Orange County, California.

The agency’s Communications Bureau, located at Police Headquarters (1 Civic Center Plaza, Irvine, CA 92606) provides a central service point for responding to both emergency and non-emergency calls for police and animal services with emergency calls taking preference. Staffing consists of 16 full-time dispatchers and 5 supervisors each of whom are committed to providing exceptional service to the public.

The Communications Bureau receives an average of 200,000 phone calls annually. The Communications Bureau operates with state-of-the-art equipment, including a computer aided dispatch system, GPS automatic vehicle location system, intelligent phone workstations and an 800 MHz trunked radio system. The center is also equipped with a video wall that allows dispatchers to view live video from a closed-circuit TV system, as well as from nearly 130 traffic intersection cameras located throughout the City. This innovative feature helps dispatchers to be more proactive in their duties by providing deployed resources with updates they may be obtaining visually.

1.1.2 Sizing Information Summary

The following information is being provided with the sole purpose of assisting Consultants in sizing the correct solution within their proposals.

Public Safety Employees	Police
Sworn Employees	232
Auxiliary Officers	2
Civilian Employees	241
Total Employee Count	475
CAD Access Equipment	Police
Dispatch and Call Taking	8
Mobile Computers	82
Desktop Computers w CAD Access	16
Desktop Computers w PD RMS Access	300
Public Safety Stats	Police
Calls for Service	187,042
Dispatched Responses, Police & Fire	187.042

1.1.3 Current CAD & Police RMS System

IPD currently utilizes disparate systems to include; Hexagon's I/CAD products, Hexagon's Ileads for records management, Trittech's Copperfire for report writing, DIMS for digital evidence management, Crossroads for citation and accidents reporting and Hyland's OnBase for case and records management.

Approximately 90% of Public Safety staff use the following systems: CAD dispatcher, CAD mobile, CAD web, California Law Enforcement Telecommunication System ("CLETS") interface, jail management, property and evidence management, report writing, investigations, case management, records management, records archiving, custom reports, and database management.

Although the City intends to evaluate the Contractor's total solution for CAD / RMS and Mobile, eExisting Sub-systems may require integration in the event the Consultant's solution does not meet the functionality requirements. These subsystems include a citation and accident reporting application called Crossroads.

The Police Department headquarters and substations are interconnected via fiber and traditional T1 circuits, but the network backbone is primarily 1GB to the desktops. The City standardized with Dell for the desktop computers and Dell OptiPlex 7010 workstations for all the dispatch console positions (all desktops and workstations run Windows 7 Pro 32bit and 64bit). Computer systems are refreshed every three years and MDC's every five years. All networking equipment is Brocade, which may be replaced by CISCO and all servers are HP.

The existing CAD system consists of 7 servers (one physical and 6 virtual). The City uses VMWare's product and plans to remain with VMWare for virtualization. The existing Dell interface servers maintain interfaces for CLETS and ALI-ANI.

Servers run Win2k8. The City's Directory Services/Domain are planned to be upgraded to either Windows 2008 or Windows 2012. The City's database standard is Microsoft SQL.

1.2 Project Goals

With a new CAD and RMS, the City's ability to prevent, respond to, manage, and analyze situations threatening the safety and property of citizens, and provide other critical emergency services

resources will be significantly enhanced. An integrated Police and RMS System will lay the foundation for intelligence led policing, enhanced criminal justice, and overall strategic public safety resource deployment.

The system must advance the overall mission, goals, and objectives of the City by making public safety personnel more effective in preventing, combating, and responding to public safety matters through strategic resource deployment.

The City is aware of current industry technologies and is seeking a balance between mainstream and state-of-the-art technology. The City wants to employ solutions that will prolong the life of the new system and postpone the need for replacement. The City envisions that the system will be based upon current, proven technology that is derived from current industry and City standards.

1.2.1 CAD, RMS and Mobile Systems Objectives

The system must be able to perform so that an operator will not have to wait for critical information and will rarely have to wait for routine information.

The system must utilize an easily understandable user interface that optimizes efficiency and the viewing of critical data in real time. Users must be able to filter information according to their preferences utilizing the mouse, hot keys and/or command line functionality. All critical functions must be accessible via the keyboard, as mousing between entries is discouraged.

The system must be easily configurable and permit the System Administrator to create, update, and manage the key records and tables, dialog boxes, status monitors, and masks, as well as create, modify, and, print reports.

The proposed solution must adhere to City's technology standards. The standards are consistent with those being adopted by public safety entities throughout the country, as well as with the interoperability standards adopted by the US Federal government. The "City Technology Standards" is being provided as Attachment "IV" within this RFP.

The system must be in compliance with Section 508 of the Rehabilitation Act of 1973, as amended (29 U.S.C. §792).

The City is increasingly adopting the .Net platform for new development and interfaces utilizing XML-based web services. Thin client applications are preferred. This consideration is critical for new and upgraded applications in the public safety arena where appropriate.

The underlying IT Infrastructure (Network, Computer, Storage) must be built on the WINTEL Platform (current version minus one), the database should be MS SQL Server, and capable of virtualization with VMware's ESX hypervisor platform. The underlying storage must offer three tiers of block level storage; Solid-State Drive ("SSD"), Serial-Attached Storage ("SAS"), Serial AT Attachment ("SATA") and dynamically move data between each tier based on access frequency.

1.3 Services

1.3.1 Project Management Services

Major City information technology projects, including the CAD, RMS and Mobile Replacement project, are managed by Consultant specific subject matter experts ("SME") and project

managers reporting to the City Project Manager as the primary lead in this project. Project sponsorship is through business units and City resources for the project are staffed and managed through a matrix management project structure. A project steering committee will oversee the CAD, RMS and Mobile project. The City expects significant project management activities to include, but not be limited to, Project Scheduling, Risk Management, Cost Management, Change Control Management, Communications Management and on-site meetings as (and when) required.

Prior to contract signing, the Consultant shall prepare and submit to the City Project Manager for approval a Statement of Work to include;

- a. Draft proposed schedule,
- b. All features of Consultants base system that are available in the base system price
- c. All features request via the functional matrix and the cost of each
- d. Annual maintenance costs, and
- e. Final Implementation Plan

1.3.2 Project Schedule

Consultant must provide draft project schedule in Microsoft Project format utilizing a Work Breakdown Structure (“WBS”) format including resources and milestones. The intent of the City is to develop and maintain a shared project schedule that includes all Consultant and City tasks and activities. Implementation schedule should incorporate the major subproject implementation phases such as CAD, RMS, Mobile, etc.

1.3.3 Consultant Project Staffing Plan

Given the high-profile nature of this project, the City expects best in class project management services from the Consultant. The City expects the Consultant shall work closely in conjunction with City’s Project Manager. The City will only accept Consultant personnel who have significant and relevant experience with the Consultant’s CAD, RMS and Mobile system and can show a successful track record at locations of similar size and complexity as the City.

Consultant shall:

- a. Identity proposed staffing resources and level of effort for each major task. Consultant must also include an organization chart for proposed project personnel, including proposed sub-Consultants.
- b. Describe expectation of City staffing resources and Level of Effort for each major phase, including expected skill set needed to successfully complete each task.
- c. List key personnel that will be assigned to the project.
- d. Provide resumes of all key staff that provides enough information to allow the City to evaluate their capability and qualifications to perform proposed tasks.
- e. Describe roles and tasks for all key personnel for each major phase of the project,
- f. Identify whether this is their major assignment, and a projection of other assignments they may be working on during the implementation period.
- g. Describe for all key personnel what percentage of time will be on project.
- h. Provide information regarding who will be on site for each major phase of the project, and who will be remote.
- i. Provide the Consultant’s escalation process of issues.
- j. Describe facilities and equipment that the City is required to provide on-site staff.

- k. Submit all Consultant personnel assigned to work on-site on the CAD, RMS and Mobile project to undergo a criminal history check. Off-site personnel may also be subject to a criminal history check. Please note that arrangements for required criminal history checks should be made in advance with appropriate City personnel. The City reserves the right to reject any personnel proposed by the Consultant for any reason. All key personnel will be required to sign a confidentiality agreement for access to sensitive data.
- l. Ensure that support personnel proposed have the necessary level of training and experience with the application suite to ensure that the City is receiving expert-level support. The Consultant may be requested to provide the City with a listing of all certificates, training courses and other relevant evidence to document the level of expertise of proposed support personnel.
- m. Understand that the Consultant's Project Manager is expected to coordinate and participate in all activities related to Consultant demonstrations.

1.3.4 Project Reporting

The Consultant shall participate, at a minimum, in a bi-weekly Project Meeting to report progress toward contract deliverables, update status from the previous reporting period, and advise current objectives, problems or delay issues, proposed corrections and other relevant information.

1.3.5 Project Status Reports

The Consultant's Project Manager shall provide, at a minimum, bi-weekly project status reports detailing relevant information to the City's Project Manager.

1.3.6 Implementation Management Plan

The City uses the Project Management Book of Knowledge ("PMBOK") as a guide for implementation of all projects. Please provide how the Consultant's implementation planning activities incorporate all of the major PMBOK phases: Initiation, Planning Execution, Monitoring & Control, and Closing. For each phase, Consultant shall:

- a. Provide the Consultant's process to complete each major phase (i.e. CAD, RMS, Mobile, AFR, etc.);
- b. Provide the Consultant's methodology to prepare servers (i.e., completed on-site or at the Consultant's location);
- c. Provide the Consultant's Deployment plan of all phases and why this methodology is being proposed;
- d. Provide the Consultant's Risk Management plan that shall be used to ensure successful implementation of all phases;
- e. Provide the Consultant's Quality Management plan that shall be used to ensure successful implementation of all phases; and
- f. Provide any Change Management solutions provided by the Consultant that are a component of the proposal.

1.3.7 Training

The Consultant shall develop a training work plan and curriculum to be approved by the City project manager in conjunction with City personnel. The work plan should also include periodic follow-up and update training when a new release or version of any application is installed. The

Consultant must develop a training plan and curriculum that specifies the required training and technical staff supporting the application. The Consultant's City-approved training schedule must be closely coordinated with City staff to coincide with the installation of the software and hardware. Upon acceptance by the City Project Manager, the Consultant shall implement said approved plan.

The City requires a hybrid training approach that utilizes both Consultant-supplied trainers, as well as a train-the-trainer capability. All initial CAD, RMS and Mobile training shall be performed by Consultant training City personnel as trainers. Thereafter, the Consultant shall shadow a training session conducted by the City trainers, who will become responsible for completing the rest of the training sessions. The shadow period is expected to run for one (1) class for each training type (dispatchers, records, field personnel and administrators).

The City requires an optional provision to have each of the dispatchers trained by the Consultant, as opposed to a train-the-trainer approach. This option will be determined at the time training is to commence and will be based on the comfort level of the project team.

The City will work with and assist the Consultant in the scheduling of the initial shadow training programs. The City shall provide space adequate for conducting the training and housing and securing the training equipment.

Given the shift assignments of public safety personnel, training courses will often need to be scheduled outside of normal working hours, including weekends and evenings. In order to keep the training relevant to the ultimate system look-and-feel, as well as fresh as possible and still accommodate the necessary number of sessions, it is expected that training will not begin until after preliminary system acceptance and before cut-over, but in no case will begin longer than 30 days prior to the scheduled "Go-live" date.

If the system Go-live date is significantly delayed due to the Consultant's actions or faults, any repeat training sessions as determined by the City must be performed at no cost to the City.

With some exceptions (e.g. System Administration training), classes will contain no more than 6 trainees for CAD training and no more than 12 trainees for RMS and Mobile systems and will not last longer than eight hours.

The Consultant shall be responsible for providing training materials and take-away documents such as user manuals and user guides and cheat sheets to adequately perform the initial training and provide follow-up reference material for the trainees. These documents should also be provided in an electronic format.

The Consultant must provide a comprehensive training program minimally covering:

- a. PSAP personnel user training;
- b. Police field personnel;
- c. Agency-Based supervisory personnel;
- d. Standard and ad hoc reporting;
- e. Records personnel
- f. CAD/RMS/Mobile system administration (including Consultant supplied Interfaces);
- g. CAD technical Operations; and
- h. GIS Functions and Operation

1.3.8 Data Conversion

It is the City's desire to have historical data from CAD and RMS systems accessible, resident or not, within the new CAD, RMS and Mobile solution. It is imperative that all historical data is either archived or maintained in a manner that allows querying of the data from the new proposed system or is converted and added to the new proposed system.

Consultants are encouraged to use their expertise in this area to provide the City applicable options in the form of a Data Conversion. The City understands there may be many methodologies available to manage legacy data in a cost-effective and user-friendly manner. The City is seeking to migrate the following data from the legacy systems:

- a. Incidents,
- b. Incident Premise History,
- c. Case Reports,
- d. Case Narratives,
- e. Case Persons,
- f. Case Property,
- g. Case Vehicles,
- h. Arrests and Associated Booking records,
- i. Case Attachments,
- j. Historical Case Report Requests,
- k. Field Interviews,
- l. Citations Data and Attachments,
- m. Accident Reports and Attachments,
- n. Pawns
- o. Equipment Lists,
- p. Personnel Data,
- q. Master Name Index,
- r. Master Property Index, and
- s. Master Locations Index,

The Consultant shall include a description of all Consultant and City processes and activities required to successfully migrate legacy data from the legacy systems into the Consultant's proposed solution. The study should include the following:

- a. The Consultant's proposed data conversion process;
- b. Specific functionality and features of the proposed solution(s). For example, precise information how City personnel would access the historical data;
- c. Specific roles and responsibilities for proposed City resources, as well as recommended skills of personnel required to perform City tasks;
- d. Specific roles and responsibilities for proposed Consultant resources, as well as recommended skills of personnel required to perform City tasks;
- e. Qualification, experience and resumes of Consultant staff proposed for the Data Conversion Task;
- f. A description of the Consultant's proposed automated data conversion tools;
- g. Recommended solutions for end-users to access non-migrated legacy data via integrated system or separate queries;
- h. Recommended storage location for non-migrated legacy data;

- i. Any prior data conversion experience with the City's legacy systems. Please list the relevant projects, the versions involved, and provide contact information for the clients. We are particularly interested in projects that involved the proposed Data Conversion personnel; and
- j. The Consultant shall include a description of its process for implementing data conversion and archiving legacy data.

Consultants shall provide pricing estimates and recommended methodology for conversion based on converting ten years of data from Hexagon's I/CAD, ILEADS and Hyland's OnBase

1.3.9 Operational Migration Plan

The migration from one CAD, RMS and Mobile system to a new one can present significant threats to the health and safety of the public and first responders if problems arise. The City CAD cutover will take place in its existing Communications Center and will require an extraordinary level of coordination and staging to avoid impacting existing operations.

Cut-over activities shall be approved in advance by the City. A cut-over working group composed of City, CAD, RMS and Mobile Consultant and other relevant personnel will be formed to develop a detailed migration plan and the actual execution of the CAD, RMS and Mobile system cut-over.

1.4 General Software Requirements

1.4.1 GIS Requirements

The City uses an ESRI GIS database. Consultant must interface with this database to develop the geo-file required for the proposed systems. The interface should be designed to load an initial file from the City's GIS and to also periodically enable updates of CAD, RMS and Mobile system's geo-file from the City's GIS database. The Consultant must provide the tools necessary for City GIS staff to perform the geo-file creation and upload process. Specific details of the City's GIS Services are outlined within this RFP in "Attachment "V", City GIS Services"

1.4.2 Browser Based Functionality

The proposed solution must include browser-based functionality. This functionality allows authorized staff to access the system from non-dispatch or call taking terminals utilizing a thin or thick client. The browser-based functionality must include:

- a. The ability to see all CAD activity in real time;
- b. The ability to see the CAD GIS map, including available units, units on calls, calls holding, active calls, etc.;
- c. The ability to send and receive messages within the system, including individuals, units, dispatch positions, call taking positions, etc.; and
- d. The ability to access information within the system, including all call information, all unit information, all timestamps, all AVL/GPS data and routing information to any location.

1.4.3 Data Purging

The system must have a purge facility that will off-load data from the servers for archival storage, access, and/or destruction. Purging must be administrator-configurable by multiple parameters. All purges must be subject to strict audit tracking and reporting and must occur while the system is fully operational, without degradation of performance.

1.4.4 Back-up and Recovery

The servers must have an appropriate automated back-up capability for system and application back-up and transactional level recovery. Back-up media shall be in a format suitable for convenient off-site storage. The system must provide differential back-up schedules for various system components and be configurable by the system administrator. Incremental and full back-up capabilities must be provided. All back-up and recovery processes must be subject to auditing and reporting. System back-ups must be accomplished without taking the application out of service and without degradation of performance or disruption to operations.

The City desires to utilize its existing backup system to perform all necessary backups providing for full-restore should an event occur that requires it. A full restore means that all primary and ancillary systems that are being backed up are restored and fully functional. If specific backup parameters are required by the Consultant, please describe those requirements in detail. If the proposal includes backup alternatives, it is required to specify the system, cost, and methodologies that will be used to accomplish the back-up and recovery of the system.

The City's current Back-Up and Recovery Software and process is more fully described in the "City Technology Standards" being provided as Attachment "IV" within this RFP.

1.4.5 CAD Stand-Alone Mode

The CAD workstations must have the ability to operate in a stand-alone, off-line mode in the event the CAD servers become unavailable. At a minimum, the system must provide the ability to track basic unit availability and status information in a standalone mode.

1.4.6 Automatic Update of Workstations/MDCs

All software updates to both desktop CAD and RMS workstations and MDC computer terminals must be accomplished through an automated network facility and not require a technician to perform a manual procedure on each workstation/MDC. This update utility must be configurable by multiple parameters, e.g., workstation type, and able to support the scheduling of update activities in batch and non-batch modes. A summary report is required, documenting the results of the update activity.

1.4.7 Data Integrity

The system must ensure the integrity of the data which it maintains. Interruptions in processing due to incidents such as aborted transactions, hardware failures, or network unavailability must not result in inaccurate or inconsistent data in the system. If data transfers occur, the system must provide a method of audit validation to ensure that all data sent was received in the target application.

1.4.8 Coding

The system shall be developed utilizing a current programming language such as .NET Framework, ASP.NET MVC, or other language acceptable to the City. The City requires Consultants to actively advance development technologies as provided by industry standards and not maintain any portion of the proposed solution with technology that is outdated, end of life, end of support, etc. The Consultant must disclose the programming language used in the proposed solution.

1.4.9 Scalability

Future requirements for regional cooperation and interoperability will only increase. Since this may result in the system being subjected to a greater than normal amount of traffic, the system must be able to scale up to handle the additional load without any performance impact, specifically on the CAD operations. Increased loads of up to 50 percent may be the result of temporary surges based on a major event. Also, the need may arise to permanently increase the standard capabilities of the system. The former will be handled by building in excess capacity over historical trends, the latter by seamlessly adding hardware and software components to adapt to the new workload. Adding or upgrading hardware components must be accomplished without bringing the system down or negatively affecting its performance.

1.4.10 Flexibility

The system shall be able to retain its performance levels when adding additional users, functions and data. The solution functionality and associated business rules must be able to be configured with the use of applications or functions that do not require "code" modifications. The screens shall be highly configurable, providing ability to reposition and rename field labels, remove or "turn-off" unused fields, maintain data, and allow the addition of user-defined fields. The system shall provide the ability to create and/or modify business rules.

1.4.11 System Reliability/Availability and Access

The public safety mission requires consistent operations, at a minimum 99.999% up time. Routine maintenance or administrative procedures must not require system "down-time" or a re-start to take effect.

1.4.12 System Administration

The proposed solution must provide a suite of system administration tools to support the effective ongoing operation of the systems. The full suite of system administration tools shall be available to appropriate City personnel. System administration capabilities, at a minimum, must include the ability to:

- a. Create and maintain user and group accounts;
- b. Integrate with Active Directory to allow for single sign on;
- c. Manage security (as described below);
- d. Manage back-up and recovery processes;
- e. Monitor and tune system performance;
- f. Install and configure hardware;
- g. Install and configure software/updates;
- h. Interface with ESRI Web Services and google maps for updating CAD geo data;
- i. Monitor and maintain interfaces;
- j. Schedule procedures (staff, assignments);
- k. Schedule report distribution;
- l. Manage disaster recovery procedures;
- m. Configure alerts;
- n. Organize and maintain system documentation; and
- o. Perform remote management.

The systems must allow the System Administrator to configure by jurisdiction, agency, or user group the display of all available information, including maps, status screens, event forms, call

entry screen, dispatch screens, and pull-down menus. Changes to one agency/jurisdiction/user-group configuration must not affect any other agency/jurisdiction/user-group configurations.

The System Administrator must be able to modify the layout and data elements displayed on all Consultant supplied forms and screen masks, and the ability to create macros or shortcuts for common user functions.

The System Administrator or other authorized user must also be able to add a report, macro, or function to the application menu and add new data elements to forms or report formats.

All system administration procedures must be supported by a detailed logging, auditing and reporting capability.

1.4.13 Database Administration

The full suite of database administration tools and capabilities for the system must be available to the City. These include, but are not limited to, the ability to:

- a. Alter on-screen field attributes, i.e., positioning, labels, drop-down lists;
- b. Specify edit and validation checks on fields;
- c. Modify content of drop-down lists; radio button lists, etc.;
- d. Perform system diagnostics;
- e. Monitor and tune database performance;
- f. Perform database back-up and recovery;
- g. Execute queries;
- h. Download data directly into Microsoft Excel, Microsoft Access, and SQL Server format;
- i. Support integration via web services;
- j. Configure alerts; and
- k. Log and archive all database activity.

Database imports and exports must be accomplished with minimal impact on system performance and must maintain the integrity of all relational linkages. Import/export tools must support both automated and ad hoc operations.

All database administration procedures must be supported by a detailed logging, auditing and reporting capability. Changes to one agency/jurisdiction/user-group configuration must not affect any other agency/jurisdiction/user-group configurations.

1.4.14 Security

A mission-critical application affecting the safety of the public, as well as the City's first responders, the system must be supported by robust security controls. Security considerations to be addressed minimally include: hardware and networks; application security; user identification and authentication; and multi-jurisdictional considerations.

Multiple firewalls, encryption, anti-virus software, intrusion detection, advanced authentication for remote users and LDAP authentication are all utilized within the existing City's systems. Software must support the City's virus scanning software.

All hardware implemented within the City networks must go through a security review and be certified by the City Information Services Manager for compliance with the City standards.

1.4.15 Security Requirements

The system/security administrator must have, at a minimum, the ability to assign different user profiles based on individual and group classifications and sub-classifications and assign differential access privileges. To protect HIPAA, CJIS and other restricted data, the System Administrator must have the ability to define security profiles down to the individual data field level. Profiles must support read-only access and selective read/write privileges. Security profiles must also be able to be assigned to individual devices such as workstations and printers.

Secure Platform Application: The Consultant must support deployment of host server and database security patches and service pack updates within one month of patch release (e.g., application running on Windows server Operating System (“OS”) should not limit installation security patches on host operating system). Application and Consultant must support new operating system versions within one year of release. Application security vulnerabilities shall be remediated with the development, testing and timely release of security patches by the application Consultant within three calendar months of the vulnerability being identified.

User Authentication/Single Sign-on (SSO): The City standard for a single point of user authentication is Microsoft Active Directory (“AD”), using the Lightweight Directory Access Protocol (“LDAP”). The City standard for authentication is to allow properly authorized users to login just once on their computer and be able to access all approved applications during that active session.

Secure Authentication: All authentication activity occurring over the network should be encrypted using FIPS to ensure that logins and passwords are not transmitted in clear text. This includes using FIPS 140-2 (at a minimum) and administrator authentication activity.

Sensitive Data: Applications containing or hosting sensitive data, as defined by State of California or US Federal law or regulation, shall encrypt data at rest, using (at a minimum) FIPS 140-2, data in motion over the network and all authentication activity. Encryption algorithm used to encrypt data and authorization activity shall be industry standard.

Auditing and Logging: Application must log all security-related events including logon, logoff, data modification, data deletion, change in rights or permission levels, and the addition of data/information to the application. Logs must include user ID generating the transaction, time of the transaction, and details regarding the activity (e.g., logon, logoff or data details). System should support interoperability with centralized logging and Security Information Event Management (“SIEM”) technologies.

Compliance with Organization’s Security Policy, Standards and Procedures - Application Consultants working directly on City-owned applications or from City facilities are subject to all City policies, standards and guidelines.

Specific security information for the City’s Public Safety Network is provided in the “City Technology Standards” being provided as Attachment “IV”.

1.4.16 Application Security Coding Requirements

- a. Parameter Manipulation: Applications shall be designed to ensure that parameter manipulation does not provide access to data or application functionality that the user is not authorized to see or use.
- b. Input Validation: Sanitize all user input fields to ensure that cross-site scripting, SQL injection and other input related vulnerabilities are closed through secure application coding. Input validation should be performed on the server/application and not on the client devices.
- c. Hidden Fields: System should not use “hidden fields” for Security.
- d. Cookies: System should not rely on cookies to define security settings. Cookies must not contain or be used to obtain sensitive information.
- e. Session Identifiers: If system uses session identifiers, they should be generated with unpredictable numbers and should contain enough key space to prevent unauthorized use or guessing of the session ID’s.
- f. Error Messages: System should handle system errors in an appropriate manner. Failed login attempts to the system should not generate detailed information about the failed login attempt (e.g., incorrect password or unknown user account). Other security related errors (e.g., file not found, or permission denied) should generate generic error responses. Detailed error information should be written to secure logs so that developers and system administrators have access to error details required to address the error. Error messages should be clear.

1.4.17 National & State Public Safety Data Standards

The US Federal government has taken the lead recently in developing standards for facilitating information sharing among local, state and federal first responders and emergency operations managers. The proposed CAD, RMS and Mobile applications must comply and be maintained to these standards.

Deviations from the architecture and standards may represent a barrier to the implementation of the City’s public safety integration and interoperability goals and may be reviewed with prejudice. All Consultants must specifically disclose all aspects of the proposed solution which deviate from the documented standards and desired architectures and provide approaches for consideration about the way non-standard components may be integrated.

The US Federal government, California Department of Justice and other parties, such as APCO, occasionally update and improve the referenced standards or develop new ones. In that the City may adopt such future standards, it is mandatory that the CAD Consultant monitor these developments and upgrade their offerings as necessary to comply.

The time between purchase of a CAD system and its implementation may be significant; therefore, it is possible that updated standards may have been released in the interim. The City shall not accept products that will be outdated by the time they are implemented. It shall be the Consultants responsibility to verify and validate all new standards as they are implemented. The City shall not be responsible for determining when new standards are required.

Consultants are encouraged to review the standards and comply at minimum to the standards associated with each of the following:

NIBRS - National Incident Based Reporting System, CIBRS - California Incident Based Reporting System and UCR-Uniform Crime Report

Capture data to report official crime statistics to the Federal Bureau of Investigation under Uniform Crime Report (“UCR”), National Incident-Based Reporting System (“NIBRS”) and California Incident-Based Reporting System (“CIBRS”), once approved by California DOJ, implemented to improve the overall quality of crime data collected by law enforcement, captures details on each single crime incident—as well as on separate offenses within the same incident—including information on victims, known offenders, relationships between victims and offenders, arrestees, weapons, and property/evidence involved in the crimes.

<https://ucr.fbi.gov/nibrs-overview>

NIEM - National Information Exchange Mode

NIEM is a product developed by the Office of Justice Programs in the US Department of Justice and adopted by the US Department of Homeland Security. NIEM describes XML schema for a variety of attributes associated with incidents and events including NCIC and NIBRS. The schemas allow for the easy sharing of data among disparate agencies and are becoming the de-facto incident-based integration and interoperability standard. Having CAD NIEM-compatible XML schemas available in a depository is required to improve the City’s ability to quickly respond to current and future data-sharing requirements. The Consultant’s solution must specifically meet Global Justice Extensible Markup Language Data Model (“GJXDM”).

<http://www.niem.gov/>

<http://it.ojp.gov/jxdm/>

LEITSC - Law Enforcement Information Technology Standards Council

The LEITSC was established by the Office of Justice Programs in the US Department of Justice to foster integrated justice systems through the definition and implementation of standards of CAD and RMS systems.

https://it.ojp.gov/documents/leitsc_law_enforcement_rms_systems.pdf

https://it.ojp.gov/documents/leitsc_law_enforcement_cad_systems.pdf

NENA – National Emergency Number Association

NENA provides 9-1-1 policy, technology, operations and education standards for public safety communication centers. The City has adopted the standards for ALI Data Exchange, ALI Response and GIS Mapping as a minimum standard. As the technology advances, the City requires compliance for NG 9-1-1 standards as adapted by NENA.

<https://www.nena.org/>

Next-Gen 9-1-1

Consultant must be prepared to meet all existing and proposed Next-Gen 9-1-1 functionality, including VOIP, Voice to Text, Text to 911, Video Submission and T.D.D. requirements.

<http://www.its.dot.gov/ng911/>

HIPAA - Health Insurance Portability and Accountability Act of 1996

HIPAA requires, among other things, that the privacy and security of protected health information be assured. This includes such information as may be transmitted and/or stored by electronic systems, including via wireless telecommunications. The CAD, RMS and Mobile systems must comply with the requirements of the law and the proposal must identify the steps taken to test and certify compliance with the standard prior to implementation.

<http://www.hhs.gov/ocr/privacy/>

CJIS Security Policy – Criminal Justice Information Services Security Policy

The CJIS Security Policy provides Criminal Justice Agencies (“CJA”) and Noncriminal Justice Agencies (“NCJA”) with a minimum set of security requirements for access to Federal Bureau of Investigation (“FBI”) Criminal Justice Information Services (“CJIS”) Division systems and information and to protect and safeguard Criminal Justice Information (“CJI”). The CAD, RMS and Mobile systems must comply with the policy and the proposal must identify the steps taken to certify compliance with the standards prior to implementation.

<http://www.fbi.gov/about-us/cjis/cjis-security-policy-resource-center/view>

CLETS - California Law Enforcement Telecommunications System

California Law Enforcement Telecommunications System (“CLETS”) is an efficient law enforcement communications network available to all public agencies of law enforcement within the state. The CLETS provides all law enforcement and criminal justice user agencies with the capability of obtaining information directly from federal and state computerized information files. The CAD, RMS and Mobile systems must adhere to the statutes established in the CLETS Policies, Practices and Procedures publication.

<http://oag.ca.gov/>

RIPA – Racial and Identify Profiling Act

The Racial and Identity Profiling Act of 2015 (“RIPA”)(AB953) requires each state and local law enforcement agency to annually report to the Attorney General data on all stops, as defined, conducted by the agency’s peace officers, and require that data to include specified information, including the time, date, and location of the stop, and the reason for the stop. The RIPA Board has established a requirement of reporting stop data by April 1, 2019. Specific required data elements are defined in Article 3. Data Elements to be Reports of the California Code of Regulations, Title 11. LAW, Division 1. ENFORCEMENT, Chapter 19, Final Text of Regulations. The proposed systems must comply with the RIPA stop data reporting requirements no later than the earliest of the dates required by the RIPA Board. Consultants must submit specification on how the proposed solution shall collect all required data elements and how the data will be reported via a secure file transfer or web service to the California Department of Justice Stop Data Collection System (“SDCS”)

<https://oag.ca.gov/sites/all/files/agweb/pdfs/ripa/stop-data-reg-final-text-110717.pdf?>

APCO - The Association of Public-Safety Communications Officials

APCO is an international leader committed to providing complete public safety communications expertise, professional development, technical assistance, advocacy and outreach to benefit and the public. APCO is an American National Standards Institute (“ANSI”)-Accredited Standards Developer (“ASD”) that develops standards for public safety communications. The CAD system must comply with these standards and the proposal must identify the steps taken to certify compliance with the standards.

<https://www.apcointl.org/>

1.5 CAD Software Requirements

The City requires the proposed CAD solution to be fully integrated with RMS and Mobile, with neither of these systems provided by a third party. The CAD solution must meet the same general requirements as depicted in “Section 1.4, General Software Requirements”.

The proposed CAD system shall facilitate incident response and communication with operations in the field. The system allows operations and communications to be augmented, assisted, or partially controlled by atomization that includes the ability for computer-controlled resource dispatching, resource status management, incident reporting and analytical information. The system must be optimized for rapid response time and system reliability. Because time is of the essence, the system must accurately provide a date and time-stamp for every activity. The system must be capable of interfacing with more than one RMS system and support the exchange of data between other agency CAD systems.

The CAD solution must be designed to conform to the national standard for computer aided dispatch functional specifications, Unified Computer-Aided Dispatch Functional Requirements (“UCADFR”), developed by the LEITSC and the Law Enforcement Information Sharing Program (“LEISP”) technical standards of the U.S. Department of Justice’s (“US DOJ”) Global Justice Extensible Markup Language (“XML”) Data Model (Global “JXDM”).

https://it.ojp.gov/documents/LEITSC_Law_Enforcement_CAD_Systems.pdf

For all exchanges generated by CAD, conformance with US DOJ’s Global JXDM is required.

The City desires a hosted or cloud-based system over a traditional server-client based solution requiring in-house expertise to support and maintain the infrastructure and software suite.

The CAD application must support complex, agency-defined resource recommendation algorithms that meet the needs of the public safety users. Resource recommendations must be based on either AVL locations and/or Patrol Beat, depending on the event type. The CAD application must maintain and track public safety resources by status and location provided by real-time AVL.

The CAD application must support complex event distribution based on event location, service agency, service type, and/or jurisdiction. Certain event types must automatically create “linked” events for multiple agencies/services and distribute each to the appropriate dispatch position.

The systems must meet the following performance specifications as measured by maximum response time. Response time is measured as the time between a user-initiated command via any mode and the return of the requested data or action from the system. The system must (at a minimum) provide 99.999% uptime performance.

Transaction	Maximum Response Time
Locally attached CAD workstations, no external data access	1 second
Locally attached CAD workstations, geo-file validation required	2 second
Locally attached CAD workstations, non-CAD data access required	3 second
Locally attached Report Server, simple query	2 second
Locally attached Report Server, complex query	3 second
Standalone MDC computer, single record access	1 second

NOTE: For each transaction listed, 95% of the occurrences must complete within the specified Maximum Response Time.

A workstation shall be deemed to be locally attached when it is in the same premise and on the same physical network as the application server. All CAD workstations located in the PSAP will be locally attached on a 1GB network backbone with 100MB to the desktop.

The maximum response time for CAD queries that necessitate access to data sources outside the City's computing environment, such as a mutual aid request or CLETS lookup, shall be measured as the response time provided by the external source plus three (3) seconds.

Response times for MDC computers shall be measured in standalone mode to discount any wireless network latency.

1.6 MDC Software Requirements

The City requires the proposed Mobile solution to be fully integrated with CAD and RMS, with neither of these systems provided by a third party. It is expected that the Mobile application will be an extension of CAD and RMS, providing the necessary functionality of a public safety user to receive and manage an incident and to further initiate and complete the reporting of an incident into the RMS system. The Mobile solution must meet the same general requirements as depicted in "Section 1.4, General Software Requirements".

The proposed Mobile system shall facilitate communication between operations in the field and the communication center, specifically for the atomization of notification of a Call for Service from the CAD to the MDC. The CAD application's Mobile component must provide the public safety user with real-time, incident-specific information. Information must be accessible with minimal effort by the operator. Routine queries and status functions must be form-driven or single function key/screen press, minimizing the need to type commands.

The Mobile environment must support multiple applications, such as mapping and field-based reporting while maintaining CAD status, messaging, and dispatch functionality as the primary operation. Third party software applications must be able to co-exist on the same mobile hardware without impacting the performance of the Mobile solution.

The City's MDC's are configured with software to provide advanced authentication as required by the CLETS and the FBI CJIS Security Policy. Specific details of the City's mobile security standards are depicted in Attachment "IV", City Technology Standards, within this RFP.

The proposed solution must be fully capable of being deployed on the City's existing hardware and operating system. The City utilizes Panasonic CF-33, Getac F110 and Getac T800 ruggedized mobile computers for police and civilian vehicles. Each MDC are equipped with a GPS chipset and accesses the City's secured network by Verizon Wireless as their public wireless carrier.

The proposed mobile solution must be capable of being utilized on a smart devices or similar functionality must be provided within an application to be used on a smart device.

1.7 RMS Software Requirements

The City requires the proposed RMS solution to be fully integrated with CAD and Mobile and be developed as a native solution and not provided by a third party. The RMS solution must meet the same general requirements as depicted in "Section 1.4, General Software Requirements".

The proposed Law Enforcement RMS solution shall provide for the storage, retrieval, retention, manipulation, archiving, and viewing of information, records, documents, or files pertaining to law enforcement operations and cover the entire life span of records development, from the initial generation of the case file to its completion. The RMS solution, at minimum, shall provide for the

following business functions: calls for service, incident reporting, booking, investigative case management, property and evidence management, arrests, warrants, traffic accident reporting, citations, field interviews/contacts, registrants, pawns, civil process orders and restraints, permits and licenses, equipment and asset management, fleet management, personnel, and analytical support (crime analysis).

The RMS solution must be designed to conform to technical standards by the US DOJ Global Justice Extensible Markup Language (XML) Data Model (Global JXDM).

The RMS shall provide, at a minimum, the following general requirements: single entry (i.e., no duplicate data entry); automatic submission of data to external sources; maximization of the utilization of code tables; provide the ability to enter and query narrative(s)/text fields; spell check and formatting capability on narrative(s)/ text fields; provide the ability to access multiple systems from a single RMS workstation; utilization of a single database (virtual or physical); validation on data entry (i.e., logical edits, edit checks for all fields); and provide the ability for operators to generate inquiries to internal (i.e., CAD and RMS) and external data sources (i.e., CLETS, NCIC, DMV, LinX) from within each module where such inquiries make sense.

The proposed RMS solution must provide the operator with, at a minimum, the ability to reuse and/or import data returned from external sources to eliminate redundant data entry. RMS must provide the capability to electronically forward RMS data to external data sources, either automatically or upon the user's request (i.e., based on agency rules embedded within RMS). The above capabilities should be based on existing and emerging criminal justice standards, including DOJ's Global JXDM; the NIEM; and the National Institute of Science and Technology (NIST), including the Electronic Fingerprint Transmission Specification (EFTS) and Facial Recognition Collection standards.

The proposed RMS solution must have basic master indices that correlate and aggregate information in the following areas: people, locations, property, conveyances (e.g., vehicles), and organizations (including businesses and gangs). Master indices eliminate redundant data entry by allowing the reuse of previously stored information and the automatic update of the master indices upon the entry of report information. Master indices information should be captured in a variety of ways to include, at a minimum during the input of, information from an incident, traffic accident, vehicle reports, citation, booking, arrest, juvenile, fingerprint, and mug shot subsystems. Prior to accepting an entry, RMS should automatically give the user the option of determining whether there is a match based on existing data. The system should support the validation and linking of addresses, commonplace names, and street intersections. Linkages among any information contained in the master indices (e.g., people to places or person to person) must be included in RMS.

The proposed RMS solution must be compatible with third party reporting tools such as Crystal Reports. The City requires the solution to provide standard reports for Federal and State Statistical Reporting, including Uniform Crime Reporting ("UCR") and National Incident Based Reporting System ("NIBRS").

The proposed RMS solution must be capable of being utilized on an MDC and a smart devices or similar functionality must be provided within an application to be used on a smart device.

1.8 Interface Software Requirements

The CAD/Mobile/RMS must be designed to operate as a component of a tightly integrated, comprehensive, multi-jurisdictional, multi-agency, multi-user, incident based public safety system. Therefore, the proposed solution must interface with several of the City's ancillary systems. For each interface, all functionality will be fully described within a Functional Specification Document ("FSD") that will be developed by the Consultant and approved by the City. The FSD shall be developed and approved after the Consultant is selected but before any work begins on the interface. In the event a standard interface exists, the Consultant shall provide, in response to this RFP, the capabilities and functionality of each interface by submitting the FSD. Each interface, if appropriate, must operate from the CAD, Mobile, RMS & Smart Device platforms.

1.8.1 ANI/ALI

An interface with the City's Public Safety Answering Points ("PSAP") software, VIPER® is required. The interface must enable incoming E9-1-1 ANI/ALI data to be automatically mapped to corresponding address and phone data fields based on the Master Street Address Guide ("MSAG") standard in the CFS event entry form and geo-locate the location of the caller on the CAD map display. The interface must support all E9-1-1 ANI/ALI formats including wire-line, Wireless Phase I and Wireless Phase II, Voice over IP, and Multi-Line Telephone Systems. The interface must enable the insertion of additional fields captured in the CFS event, including ESN, call type (landline, wireless), and ANI/ALI tracking ID (if available).

If the Consultant has an integrated PSAP software application as part of the CFS process, the integration shall be included as standard functionality and not be delivered nor implemented as a secondary option.

Next Generation 9-1-1 (NG-9-1-1)

The Consultant shall be responsible for progressive research and development of new technologies as they relate to NG-9-1-1 to be capable of receiving cellular calls, text messages, instant messaging, legacy 9-1-1 calls (wireline), telematics (automatic crash notification) data directly from the vehicle, VoIP calls, and live video feeds. The Consultant shall include this functionality as standard functionality and not be delivered nor implemented as a secondary option.

The Consultant shall describe their vision, both immediate and long-term, for CAD-integrated Next Generation 9-1-1 services. This should include a description of NG9-1-1-associated data management (receipt, case integration, storage and retention), as well as access for both CAD and mobile users. The Consultant shall describe any NG9-1-1-related capabilities, functionality and features of the proposed CAD system, including any integration of NG9-1-1 data into the CAD call workflow.

To the extent that the functional elements of NG9-1-1 are defined, The Consultant is required to describe the proposed solution's ability to meet NENA i3 (08-002/08-003) and associated standards. The City recognizes that current NENA standards do not specifically address core CAD functionality; however, it is clear that there are points of interaction with standardized i3 functional elements. Consultant shall describe how the proposed CAD solution will be updated as new and revised standards, functionalities and features are developed, as well as how data elements from NG9-1-1 and CAD are managed to ensure data received from NG9-1-1 is usable without extensive reformatting by the CAD solution.

References:

<http://www.its.dot.gov/ng911/>
http://www.nena.org/?page=FuncInterface_NG911

1.8.2 Alarm Monitoring Company Public Safety Answering Point

The City is anticipating implementing an interface to provide the atomization between an Alarm Monitoring Company and the City's Public Safety Answer Point ("PSAP"). The proposed solution must be capable of establishing a bi-directional interface to receive an initial notification of an alarm event and provide status updates by the PSAP to the initiating alarm company. Bi directional updates may include the request for cancellation by the alarm company, updates by the key-holders information, notifications by the PSAP of the primary response along with associated status changes such as a unit being dispatched, arriving on scene and closing of the incident with disposition.

<https://www.apcointl.org/resources/interoperability/asap-to-psap/asap-to-psap-protocol/>
<https://www.apcointl.org/download/alarm-monitoring-company-to-psap-cad-automated-secure-alarm-protocol-asap/?wpdmdl=5938>

1.8.3 License Plate Reader – Vigilant Solutions

The City Police Department uses a License Plate Reader ("LPR") system by Vigilant Solutions. Vigilant Solutions provides the capability to interface their technology with CAD to assist in automating alerts within CAD and/or the MDC's for matches against various hotlists. The proposed solution must provide the ability to interface with Vigilant Solutions Mobile LPR solution.

1.8.4 Radio Console Interface / Push to Talk

The City utilizes Project 25 ("P25") compliant fixed mount and portable radios by Motorola in conjunction with a Motorola MCC 7500 IP Dispatch Console. The proposed solution must provide ability to display on a CAD workstation, the radio Push to Talk ("PTT") IDs and EIDs (Emergency IDs) when received by the dispatcher for Police. The IDs must include the Unit Radio Name (i.e. 100M or E1...etc.) and the location, by address or cross street as determined by GPS data provided by the P25 compliant radio. In addition, the proposed solution must also display "Action Commands" as entered in the field on an MDC or other mobile device, i.e. "Acknowledged", "Enroute", "Staged", "Onscene", "Clear", "Change Location", etc.

1.8.5 Global Positioning System (GPS) / Automatic Vehicle Location (AVL)

The City requires that the CAD/Mobile/Smart Device applications utilize the most current, real-time to near real-time location of each police vehicle and/or personnel. Latitude and Longitude information needs to be converted to address data and appropriately displayed on the integrated CAD and Mobile maps. The CAD and Mobile applications must be able to manually poll any GPS-equipped vehicle or person by assigned radio, MDC and/or Smart Device. The CAD and Mobile applications must be configurable to control the automatic polling update rate based on location, status, time and/or distance, or any combination thereof. GPS data is available from following:

Mobile Data Computers: The City utilizes a Panasonic and Getac Rugged Tablet equipped with a built in GPS chipset in police vehicles. The system must be capable of being configured to track the location of the MDC as the primary method of receiving GPS data for vehicle location.

Radio System: The City utilizes Motorola P25 compliant radios equipped with an internal GPS receiver and should be used as the primary, or secondary method of receiving GPS data. The system should be capable of being configured to track the location of the portable radio if the portable radio assigned to an officer is not within a defined perimeter of the vehicle they are assigned to.

Cellular/Smart Devices: The City utilizes a variety of cellular enabled smart devices to include, Apple IOS, Android and Windows based operating systems. Most devices are equipped with Assisted GPS (A-GPS). The system should be capable of being configured to track the location of the smart device assigned to an officer, and if necessary, be a secondary method of tracking the location of the assigned officer if the smart devices is not within a defined perimeter of the vehicle they are assigned to.

1.8.6 Records Check System

The City requires an interface be implemented to provide the ability to access and complete either; queries, locating, entering, modifying, clearing, cancelling, and or commenting on records on multiple systems either individually, or a combination thereof.

The Records Check system must be capable of accessing; agency local databases such as CAD and RMS, state databases such as the CLETS and DMV, National Databases such as NLETS/NCIC, Local Databases such as the local Orange County Automated Telecommunications System ("OCATS") system and the regional LInX and CopLink Databases.

In addition, the Consultants must provide their experience in completing each of the following interfaces and where applicable, provide the experience in working with specific applications that are depicted below.

1.8.7 California Dept of Justice CLETS

The City requires an interface to; the CLETS for the purpose of accessing files of the CJIS, the Department of Motor Vehicles ("DMV"), the National Crime Information Center ("NCIC"), and the National Law Enforcement Telecommunications System ("NLETS") over the California Department of Justice ("CA DoJ") secure telecommunication backbone. Connectivity to the CLETS is through the Orange County Sheriff's Department's OCATS message switch. The Orange County Sheriff's Department is the CLETS Direct Interfaces System Host for Orange County.

The interface shall be designed to handle all CLETS traffic; transmitting and receiving responses to inquiries, entries and updates, and the processing of administrative messages such as All-Point Bulletins on a statewide or nationwide basis.

The CLETS interface must provide for all data forms currently available for the CLETS system to complete queries, locating, entering, modifying, clearing, cancelling, and or commenting on records including LoJack records. The interface must be able to "nest" queries (example, when a registered owner's information is returned from a vehicle tag query, the system automatically runs the registered owner's information, etc.).

The interface shall present the returned CLETS information in a formatted display with capability to add specific returned information as a supplement to the CAD incident or RMS record, or be forwarded to an MDC or smart device application. The proposed solution shall also provide for the display of images (mug shots, driver's license or ID photos, etc.).

The interface shall provide the ability to “spawn” additional queries based on the information returned from a previous query to any other interfaced database. The ability to generate spawned queries shall be configurable by a system administrator (example, when a return from CLETS is received and the info contains the name of an individual, the system shall spawn an additional query to the regional LInX database).

The proposed solution should provide the ability to perform multiple simultaneous searches from a single-entry screen form (i.e. with a single entry of identifying information in a query) and automatically search CLETS, NCIC, DMV, local databases via OCATS, and the resident CAD, RMS and BOLO files, etc.

1.8.8 Orange County Automated Telecommunications System (“OCATS”)

The Orange County Sheriff’s Department maintains a message switch, known as OCATS for local subscribing agencies to inquiry and update records within the local Automated Jail System (“AJS”), Automated Warrant Services System (“AWSS”), and the Local Arrest Records System (“LARS”). The City intends to maintain its direct interface with OCATS for performing queries of the local systems similar to the CLETS system. OCATS has established an established protocol for CAD and RMS providers. The proposed solution must provide for the simultaneous query of both CLETS and the OCATS system.

1.8.9 Law Enforcement Information Exchange (“LInX”)

The City is a participating member of the So Cal LInX Region. LInX is a national cooperative law enforcement data share consisting of participating members of municipal, county, state and federal law enforcement agencies broken down into 12 regions, primarily in jurisdictions with military bases nearby.

The LInX database consists of law enforcement data to include: Incident Reports, Accident Reports, Warrants, Arrest Reports, Booking Records, Field Interviews/Contacts, Pawn Shop Records, Citations, Traffic Stops, Sexual Offender Registry, Mugshots, Photo’s Associated with Record Types, Narratives and Supplemental Narratives.

LInX has established a web service interface using NIEM-based LEXS S/R standards, specifically, Global Justice Extensible Markup Language Data Model (“GJXDM”).

<http://it.ojp.gov/jxdm/>

The proposed solution must provide the ability to export data to the LInX system with the ability to control what data and when the data shall be sent with the ability to restrict sensitive data. In addition to providing data to LInX, the City intends to have a direct interface with LInX for performing queries of the LInX database similar to queries of the CLETS system. The proposed solution must provide for the simultaneous query of both CLETS and LInX.

1.8.10 California Dept of Justice - Cal-Photo

The California Department of Justice (“DOJ”) Cal-Photo application provides law enforcement users with the ability to search and retrieve DMV images from DMV, and Mugshot images from the various connected Law Enforcement Agency (“LEA”) image databases throughout California. These images are instantly available through an XML for a computer to computer interface using

a custom interface. The proposed solution must provide for the simultaneous query of Cal-Photo in conjunction with CLETS queries.

1.8.11 California Dept of Corrections and Rehabilitation - Parole LEADS

The CDCR has an externally published web service to enable law enforcement agencies the ability to automate inquiries via a Simple Object Access Protocol ("SOAP"). The proposed solution must provide an option to simultaneously query the Parole LEADS system in conjunction with CLETS queries.

1.8.12 Forensic Logic (formerly CopLink)

Similar to LinX, the City is a participating member of CopLink. CopLink, now owned by Forensic Logic, is a data sharing and crime analytics platform designed to help law enforcement organizations by providing tactical, strategic and command-level access to vast quantities seemingly unrelated data.

<https://forensiclogic.com/platform/>

The CopLink database consists of law enforcement data to include: Incident Reports, Accident Reports, Warrants, Arrest Reports, Booking Records, Field Interviews/Contacts, Pawn Shop Records, Citations, Traffic Stops, Sexual Offender Registry, Mugshots, Photo's Associated with Record Types, Narratives and Supplemental Narratives.

The proposed solution must provide the ability to export data to the CopLink system with the ability to control what data and when the data shall be sent with the ability to restrict sensitive data. In addition to providing data to CopLink, the City intends to have a direct interface with CopLink for performing queries of the CopLink database similar to queries of the CLETS system. The proposed solution must provide for the simultaneous query of both CLETS and CopLink.

1.8.13 Crossroads Software – Citation, Analytics and Report Writing

The City utilizes Crossroads Software for citations and collision reports. The software provides for analytics and report writing functions. Crossroads provides a desktop application as well as a mobile application on a handheld device with Microsoft Windows Mobile Operating System. Data from these devices is synchronized with a centralized server which is interfaced with the Orange County Court. The proposed solution must provide the ability to interface with Crossroads for ingesting Citation and Accident data elements, and associated attachments to a report to include file formats consistent with pictures and portal document format ("PDF").
LJTEapon4jsf

If the proposed solution includes an Accident and/or Citation module as part of the solution, the Consultant should provide details of the functionality and whether the module can be run on a hand-held device utilized in the field. An interface with Orange County Courts will be required.

1.8.14 License Plate Reader – Vigilant Solutions

The City Police Department utilizes a License Plate Reader (“LPR”) system by Vigilant Solutions. Vigilant Solutions provides the capability to interface their technology with CAD to assist in automating alerts within CAD and/or the MDC’s for matches against various hotlists. The proposed solution must provide the ability to interface with the LPR solution to alert dispatchers and patrol officers on a hot hit from a stationary trailer or vehicle mounted reader. Upon recognition of a hot hit, the CAD system shall receive the location of reader at the time of the hot hit, and the captured photo and an indication of the status of the plate, whether lost, stolen, or if the vehicle is wanted or of interest. Upon receipt of a hot hit, the CAD system must complete an automated CLETS query. The CAD system must create a call for service/incident, utilizing the location provided by the hot hit, and if from a vehicle mounted reader, assign the unit to the incident. Further requirements will be defined in an interface functional specification.

1.8.15 California Highway Patrol - Allied Agencies to SWITRS Reporting Services

The California Highway Patrol (“CHP”) Allied Agencies Reporting Service (“AARS”) has developed a system for Allied Agencies (“AA”) to transmit collision data electronically to the CHP Statewide Integrated Traffic Records System (“SWITRS”) by way of a web service known as AARS Web (Collision) Reporting Service. The proposed solution must provide the ability to interface with the AARS Web Reporting Service for electronic submission of collision data.

1.8.16 LiveScan

The City utilizes live scan hardware to capture and store biometrics that includes fingerprints, data and a mugshot to the regional Cal-ID system. The proposed solution must provide the ability to interface with the live scan hardware to provide data required by the live scan system to eliminate the need to manually re-enter data. In addition, the interface must be capable of ingesting a mugshot provided by the live scan system and associating it with master name record the RMS.

1.8.17 Lexis Nexis – Desk Officer Reporting System

The City has implemented a citizen self-reporting system called Desk Officer Reporting System (“DORS”) by Lexis Nexis. The DORS system is exposed to the citizens by way of the City’s website. The City is currently allowing citizens to submit report on: attempted thefts, petty theft, mail theft, lost property, vandalism and vehicle tampering and allowing citizens to file for a bicycle license or request patrol checks for home while vacationing. The proposed solution must be capable of ingesting the information from the DORS system and created associated calls for service and case files within the RMS system.

https://risk.lexisnexis.com/-/media/files/government/dors_brochure-pdf.pdf

1.8.18 Orange County District Attorney – Electronic Direction for Compliant

The City is interested in interfacing directly with the Orange County District Attorney (“DA”) to submit arrest and case information electronically to the DA’s Case Management System via their Electronic Directions for Complaint (“EDC”) interface. The DA’s IT Department is currently developing an API for the interface. The proposed solution must be capable of sending arrest and case related information to the CA and provide the ability for a user to determine the data

and associated case reports and attachments to be sent. Given this interface is new to the DA, the DA may be open working the CAD/RMS provider to comply with a current interface deployed.

1.8.19 Video Management System

The City utilizes an array of camera systems and has access to private camera systems throughout the City. The proposed solution must be capable of integrating with these systems to provide a display of the physical location of each camera, the cameras field of view, and provide a link to access and display the live feed of the selected camera or cameras.

1.8.20 Body Warn Camera / Dash Mount Camera Metadata Tagging

The City currently utilizes dash mount camera and will be deploying body-worn cameras in the future. The proposed solution must provide an interface to provide data to be utilized for tagging videos. Data element should include the incident ID, type of incident, location of incident, the unit(s) assigned to the incident, the personnel assigned to the incident, and time stamp to be utilized to associate status changes during the incident. Further requirements will be defined in an interface functional specification.

1.8.21 CAD-to-CAD Interface

The purpose of the CAD-to-CAD interface is to connect disparate CAD systems for the purpose of exchanging data to assist in the transfer or receipt of a call for service of neighboring police agencies and to allow the transfer of each agencies resources location and status information.

The proposed interface functionality, whether a single instance for multiple CAD system or a single instance for each CAD connection, must be capable of, but not limited to, the following: establishing a heartbeat to monitor the connectivity of the two systems; sending and receiving incident data; establishing a link between the incidents on either end for updates; acknowledgment of receipt of an incident; assigned resource identification and corresponding status changes of each assigned resource; resource position (GPS) or location sharing; incident cancellation processing; request for shared resources; and messaging between the two CAD systems. The interface shall provide an audit trail of the exchanged information to enable research by way of querying the data.

Ideally, the CAD-to-CAD interface in its basic function is a single data exchange switch facilitating the exchange of data between each of the disparate CAD systems to enable a dispatcher on either end of the interface to visually monitor the current location and status of neighboring agencies resources and to enable the CAD system to make resource response recommendations based on the known real-time location and proximity of the resources, regardless of which agency the resource belongs to. Initiation of the request for resource response shall be automated by sending incident information and the requested resources to the neighboring agency's CAD system. Upon receipt, the receiving dispatcher shall manually accept or deny the request and manage the dispatching functions resident to their CAD system.

The City wants to explore an interface for each of the following agencies:

1. Orange County Fire Authority ("OCFA"). The interface would be with Tellus (formerly FatPot) which is interfaced with the OCFA TriTech CAD system.
2. Orange County Sheriff's Department ("OCSD"). The interface would be direct with the agency's TriTech CAD system.

1.8.22 Tow Provider Interface

The City currently contracts with several tow providers and utilizes a rotation process to identify which provider is to be utilized when a request for tow is initiated. The City desires an output from the CAD for service requests that could be sent via an email, a page or SMS text, a fax, or an interface to the tow provider CAD system. The City may, in the future, integrate with a regional system dispatching and tracking system. The proposed solution must provide the capability of a notification at minimum. Further requirements will be defined in an interface functional specification.

1.8.23 DIMS Digital Information Management System

The City utilizes Linear DIMS Software for digital evidence. The software manages the acquisition of digital images and video. If the proposed solution includes a digital evidence module as part of the solution, the Consultant should provide details of the functionality. If the functionality of DIMS is preferred the proposed solution must provide the ability to interface with DIMS.

1.9 *System Testing, Reliability and Acceptance*

The City requires a system acceptance process comprised of at least the following components; the System Test Period, the System Reliability Period, and the Final System Acceptance as described further below. During the System Test Period and the System Reliability Period, if the system reveals any major defects or several minor defects impacting the completion of testing and/or production use of the system, the process shall be terminated, and the Consultant shall reasonably resolve outstanding issues. Once the issues have been addressed, the Consultant will recommence. The Consultant shall describe its trouble reporting, priority, and severity plan for this process. The Consultant shall describe responses to failed user acceptance tests, including when the testing must be held in abeyance, and recommenced in its entirety from the beginning as may be required by the City.

1.9.1 System Test Period

The Consultant’s software shall be delivered to the City accompanied with written documentation stating the system is ready for testing and a draft acceptance test plan (“ATP”) for the City to use in its acceptance testing process. The City will review the written draft of the testing plan and schedule the installation of the software within the City test environment. The acceptance test period shall begin when the City, along with the assistance of the Consultant, first performs all tests in accordance with the ATP and successfully completes the tests. If major defects or numerous minor defects are found during the acceptance testing, the tests shall be terminated, and the Consultant shall resolve outstanding issues.

Once all issues have been addressed, the Consultant will recommence the ATP process, in its entirety, from the beginning as may be required by the City.

The Consultant shall provide the City with draft test plans that include, but is not necessarily limited to the following:

- a. Drafting a test plan for City staff;
- b. User acceptance testing;
- c. Product performance testing;

- d. Interfaces testing;
- e. Security testing;
- f. Data conversion testing;
- g. Hardware and network capacity testing;
- h. Integration testing;
- i. Load testing; and
- j. Fail-over testing.

The City shall be responsible for conducting a final unit, subsystem, and system acceptance test that shall include, but is not necessarily limited to, the following:

- a. Testing all software components in accordance with published functions and features;
- b. Testing all software components;
- c. Testing all system software based on business scenarios;
- d. Testing all system software based on user friendliness;
- e. Testing of all contracted interfaces based on design and business scenario;
- f. Parallel testing prior to cutover (if parallel processing is appropriate);
- g. Security testing;
- h. Data Conversion testing;
- i. Testing based on business scenarios;
- j. Hardware and network capacity testing;
- k. Integration testing;
- l. Load testing; and
- m. Fail-over testing.

The Consultant shall review the City's additions to the test plans for accuracy and completeness. The City reserves the right to revise the test plans provided that reasonable notice is given to the Consultant. The City maintains sole authority to certify the successful completion of any and all tests performed by the Consultant on the proposed system.

1.9.2 System Reliability Period

After the successful completion of the cutover period, there shall be a minimum of ninety (90) day reliability testing during which the newly installed system will be in production and its performance monitored. During this period, the system must perform fully without degradation of any kind for the System Reliability Period to be satisfied. If any major defects or numerous minor defects are discovered, the System Reliability Period shall be terminated, and the Consultant shall resolve all issues. Once all issues have been addressed, the Consultant shall recommence the System Reliability Period, in its entirety, from the beginning as may be required by the City.

Severity levels pertaining to the system are defined as:

Severity Level 1 (S1): Critical system errors, which are defined as: Loss of Data, Corruption of Data, or Loss of Productive Use of the System. In the event this type of error occurs, the City shall immediately notify Consultant and the ninety (90) day Reliability period shall be cancelled. Consultant personnel shall promptly resolve the problem at no additional cost and a new ninety (90) day Reliability period shall begin. Once the system operates for (90) consecutive days without a Severity Level 1, the ninety (90) day Reliability test shall be completed.

Severity Level 2 (S2): Critical errors exist when the primary purpose of the Consultant's CAD/Mobile software is compromised, and productive use of the system is significantly impacted. A procedural workaround is either not immediately or readily available or has been proposed and has been found to be unacceptable by the City. In the event this type of error occurs, the City shall immediately notify the Consultant and the ninety (90) day Reliability period shall be suspended. The Consultant's personnel shall promptly resolve the problem at no additional cost to the City, and the ninety (90) day Reliability period shall re-commence at the point where it was suspended.

Severity Level 3 (S3): Non-critical errors which are defined as incomplete operation of system where a procedural workaround is readily and immediately available, and productive use of the system is not significantly impacted on software or operations. In the event this type of error occurs, the City shall immediately notify the Consultant, but the ninety (90) day Reliability period shall continue. If possible, the Consultant shall resolve the problem during the ninety (90) day Reliability period, but if necessary, resolve in a future bug fixes release of the product.

Severity Level 4 (S4): Cosmetic errors which are defined as configuration issues that can be corrected by the City, data integrity issues that must be addressed by the City, Help File documentation errors, or enhancements that can be made in the future to the presently installed system. Severity level 4 defects shall be remedied within a future software fixes release.

1.9.3 Final System Acceptance

At the successful completion of the System Reliability Period and completion of all data conversions, and demonstration they system backup and recovery features function successfully, the City shall issue final acceptance certificate.

1.10 *Hardware Requirements*

All hardware must be new equipment delivered in the manufacturers' original packaging and carrying the manufacturers' full warranty. The warranty period begins after system acceptance and certification by the City that the equipment is in production use. All equipment must be installed according to manufacturers' requirements.

All hardware components must be sized appropriately to ensure that the performance requirements of the Consultant's application will be met. Equipment specifications provided by the City within this RFP shall be considered as minimal requirements. All servers provided by the Consultant shall, at a minimum, meet the City Technology Standards as outlined in Attachment "IV" within this RFP.

Consultant must provide servers and workstations that meet the following minimum requirements:

1.10.1 CAD Servers:

The Consultant shall furnish and install the necessary Servers to support the CAD and all Interfaces and Report Server(s). All server architecture must comply with the City's IS Technology Standards provided in Attachment "IV" in this RFP, and leverage VMware's virtualization technology and Industry Standard 3rd Party Automated Tools to facilitate high-availability and immediate failover from a network, computer, and storage layer.

The Consultant shall recommend the quantity and provide such servers as to meet or exceed the minimum requirements of their software and the required performance standards delineated within this RFP.

The operating system kernel may not be modified. All support for hardware redundancy must be provided by Consultant-supplied middleware and firmware that can be upgraded as required.

The solution must provide the guaranteed availability of 99.999% uptime (at a minimum), utilizing fully redundant hardware i.e., functionally critical hardware within the single server must be duplexed. Interface and Report Servers are not required to be fault tolerant. For the primary CAD servers, the following components must be fully redundant, at minimum:

Motherboard, including CPU chipsets and Memory DIMMs

The motherboards must be completely encased for safety, and designed to allow insertion and removal, for repair, without shutting down the operating system, or the applications.

Disk Drives

All disk drives in the proposed solution must use RAID 1 mirroring (*at a minimum*). This data protection must be provided with redundant SAS controllers that perform all Input/Output (“I/O”) operations across a redundant bus. The mirror technique must be implemented in a fashion that has no performance penalty. All disk drives must be completely encased for safety, and designed to allow insertion and removal, for repair, without shutting down the operating system, or the applications.

Power Cords

Two external, twist-locking power cords are required for the proposed solution. The server must have onboard dual power supplies with dual power cords connected to two separate and distinct Uninterruptible Power Supplies connected to two separate power circuits.

For security reasons, all encased components must be designed so that City personnel and/or operational staff can be trained in the replacement of failed parts. Replacement parts must be shipped to the City utilizing a priority overnight carrier with guaranteed delivery.

The proposed server solution must contain self-diagnosing logic that will determine, based on error thresholds, if a component is failing. Once that determination is made, and without human intervention, the server must be capable of contacting the supplying Consultant and requesting replacement components.

The Consultant shall maintain a support infrastructure that is fully operational 24 hours per day, and seven days per week. This infrastructure must be global in nature, and also accept calls from City personnel as they have questions or issues pertaining to the proposed solution.

1.10.2 Workstations

The Consultant shall furnish and install six (6) workstations to support the Operations, Training, and Testing environments. The Consultant shall provide such workstations as to meet or exceed

the minimum requirements of their software and the required performance standards delineated within this RFP. All workstation architecture must comply with the City's IS Technology Standards as outlined in Attachment "IV" within this RFP.

1.10.3 Position Requirements

- a. Eight (8) – Combination Dispatch and Call Taking Positions
- b. Site License – Mobile Computers
- c. Site License – Browser Based Functionality
- d. Site License – Police Records Management System
- e. Site License – Records Check System

1.10.4 CAD Printers

The Consultant shall provide two (2) laser printers to support the printing of reports. The printer must have a network interface controller ("NIC") installed. All printers, at a minimum, must comply with the City's IS Technology Standards as outlined in Attachment "IV" within this RFP.

1.11 Licenses

Consultants shall provide a copy of all end user software license agreements ("EULA") that they will be requesting the City to execute.

1.12 Maintenance, Support and Updates

The Consultant shall make available to the City all updates to the software, as they are released, at no additional charge, so long as the City is currently under the Consultant's software maintenance agreement. To ensure that documentation is consistent with the operating environment, updated documentation must be delivered concurrently with the software update.

1.13 Warrant

The Consultant shall include in its proposal a list and description of warranties provided, including, but not limited to:

- a. Warrant of Performance – one-year performance warranty covering the specifications for and performance of all software and services, commencing upon system acceptance;
- b. Warrant of representations made by Consultant in response to RFP;
- c. Warrant Against Viruses – Consultant warrants against deliberate time bombs – encrypted key technology to disable the system or otherwise hinder system functionality;
- d. Warrant of Consultant Capability – Consultant is financially viable and there are no legal proceedings against the Consultant that could jeopardize this agreement;
- e. Warrant of Past Success – System is installed and running at other similar locations, and there is no pending litigation against the Consultant based upon problems with the system and Consultant performance;
- f. Configuration Warrant – Consultant warrants that the system provided and installed includes all components necessary to perform the processing presented; and
- g. Release Warrant – Consultant warrants the combination of hardware, software, and operating system requirements.
- h. Product Continuance Warrant- Consultant warrants the continuance of their product including incorporating state and federal mandates, and/or the ability to transition without cost to their refreshed product line.

1.14 **Quality Control**

This RFP requires the establishment of a quality control system by the Consultant to ensure that hardware and software supplies and/or services meet the quality standards explicitly and implicitly specified in this RFP. The quality control system, including procedures, is subject to surveillance by the City.

The quality control system and procedures shall be designed by the Consultant. The Consultant's procedures used to implement the requirements of this sub-specification shall be subject to the approval of the City. In the event of disapproval, the Consultant is solely responsible for devising new procedures that meet with the explicit approval of the City.

The quality control system shall ensure that adequate control of quality is maintained throughout all areas of contract performance, including, as applicable, the receipt, identification, stocking, and issuance of material; the entire physical process of manufacture, packaging, shipping, storage, installation, and maintenance; and processes of software development including design structure, coding, testing, integration, and implementation.

All equipment, supplies, and services under the contract, whether manufactured or performed at the Consultant's facility or at any other source, shall be subject to control at such points as necessary to ensure conformity with the specifications and contractual requirements. The proposed solution shall provide for the prevention and ready detection of discrepancies and for timely and positive corrective action. The Consultant must make objective evidence of quality performance readily available to the City.

ATTACHMENT II

AGREEMENT FOR CONSULTING SERVICES

THIS AGREEMENT FOR CONSULTING SERVICES (the "Agreement") is made and entered into as of _____ 2019, by and between the CITY OF IRVINE, a municipal corporation ("City"), and _____, a (insert legal entity such as "sole proprietorship" or "California corporation") ("Consultant").

PART I

FUNDAMENTAL TERMS

A. Location of Project: The City of Irvine location(s) as set forth in PART IV, Scope of Services, included herein.

B. Description of Services/Goods to be Provided: Public Safety CAD/RMS Mobile Software Replacement in accordance with PART IV, Scope of Services, included herein (reference RFP 19-1511).

C. Term: Unless terminated earlier as set forth in this Agreement, the services shall commence on June 30, 2019 ("Commencement Date") and shall continue through December 31, 2021.

D. Party Representatives:

D.1. The City designates the following person/officer to act on City's behalf:
Jade Mazzio, email: jmazzio@cityofirvine.org

D.2. The Consultant designates the following person to act on Consultant's behalf:
_____, email: _____

E. Notices: Consultant shall deliver all notices and other writings required to be delivered under this Agreement to City at the address set forth in Part II ("General Provisions"). The City shall deliver all notices and other writings required to be delivered to Consultant at the address set forth following Consultant's signature below.

F. Attachments: This Agreement incorporates by reference the following Attachments to this Agreement:

- | | | |
|------|-----------|--------------------|
| F.1. | Part I: | Fundamental Terms |
| F.2. | Part II: | General Provisions |
| F.3. | Part III: | Special Provisions |
| F.4. | Part IV: | Scope of Services |
| F.5. | Part V: | Budget |

G. Integration: This Agreement represents the entire understanding of City and Consultant as to those matters contained herein. No prior oral or written understanding shall be of any force or effect with regard to those matters covered by this Agreement. This Agreement supersedes and cancels any and all previous negotiations, arrangements, agreements, and understandings, if any, between the parties, and none shall be used to interpret this Agreement.

IN WITNESS WHEREOF, the parties have executed and entered into this Agreement as of the date first set forth above.

CITY OF IRVINE

CONTRACTOR NAME

By: _____
Jimmee Medina
Its: Director of Human Resources
and Innovation

By: _____

Its: _____

By: _____
John A. Russo
Its: City Manager

By: _____

Its: _____

By: _____
Donald P. Wagner
Its: Mayor of the City of Irvine

Attest:

By: _____
Molly McLaughlin
City Clerk

Contractor Information
Address for Notices and Payments:

APPROVED AS TO FORM:
RUTAN & TUCKER, LLP

Jeffrey Melching

Attn:

PART II**GENERAL PROVISIONS****SECTION ONE: SERVICES OF CONSULTANT**

1.1 Scope of Services. In compliance with all terms and conditions of this Agreement, Consultant shall provide the goods and/or services shown on Part IV hereto ("Scope of Services"), which may be referred to herein as the "services" or the "work." If this Agreement is for the provision of goods, supplies, equipment or personal property, the terms "services" and "work" shall include the provision (and, if designated in the Scope of Services, the installation) of such goods, supplies, equipment or personal property.

1.2 Changes and Additions to Scope of Services. City shall have the right at any time during the performance of the services, without invalidating this Agreement, to order extra work beyond that specified in the Scope of Services or make changes by altering, adding to, or deducting from said work. No such work shall be undertaken unless a written order is first given by City to Consultant, incorporating therein any adjustment in (i) the Budget, and/or (ii) the time to perform this Agreement, which adjustments are subject to the written approval of the Consultant. City approval and/or payment for work claimed by Consultant as changed or additional shall not act to prevent City at any time to claim such work is covered by the Scope of Work and should be performed by Consultant without additional consideration due. It is expressly understood by Consultant that the provisions of this Section 1.2 shall not apply to services specifically set forth in the Scope of Services or reasonably contemplated therein. Consultant hereby acknowledges that it accepts the risk that the services to be provided pursuant to the Scope of Services may be more costly or time consuming than Consultant anticipates and that Consultant shall not be entitled to additional compensation therefor.

1.3 Standard of Performance. Consultant agrees that all services shall be performed in a competent, professional, and satisfactory manner in accordance with the standards prevalent in the industry, and that all goods, materials, equipment or personal property included within the services herein shall be of good quality, fit for the purpose intended.

1.4 Performance to Satisfaction of City. Notwithstanding any other provision herein, Consultant agrees to perform all work to the satisfaction of City within the time specified. If City reasonably determines that the work is not satisfactory, City shall have the right to take appropriate action, including but not limited to: (i) meeting with Consultant to review the quality of the work and resolve matters of concern; (ii) requiring Consultant to repeat unsatisfactory work at no additional charge until it is satisfactory; (iii) suspending the delivery of work to Consultant for an indefinite time; (iv) withholding payment; and (v) terminating this Agreement as hereinafter set forth.

1.5 Instructions from City. In the performance of this Agreement, Consultant shall report to and receive instructions from the City's Representative designated in Paragraph D.1 of Part I ("Fundamental Terms") of this Agreement. Tasks or services other than those specifically described in the Scope of Services shall not be performed without the prior written approval of the City's Representative.

1.6 Familiarity with Work. By executing this Agreement, Consultant warrants that Consultant (i) has thoroughly investigated and considered the scope of services to be performed, (ii) has carefully considered how the services should be performed, and (iii) fully understands the facilities, difficulties, and restrictions attending performance of the services under the Agreement. If

the services involve work upon any site, Consultant warrants that Consultant has or will investigate the site and is or will be fully acquainted with the conditions there existing, prior to commencement of services hereunder. Should the Consultant discover any conditions, including any latent or unknown conditions, which will materially affect the performance of the services hereunder, Consultant shall immediately inform the City of such fact in writing and shall not proceed except at Consultant's risk until written instructions are received from the City's Representative.

1.7 Identity of Persons Performing Work.

(A) Consultant represents that it employs or will employ at its own expense all personnel required for the satisfactory performance of any and all tasks and services required hereunder. Any personnel performing the services under this Agreement on behalf of Consultant shall at all times be under Consultant's exclusive direction and control. Consultant shall pay all wages, salaries, and other amounts due such personnel in connection with their performance of services under this Agreement and as required by law.

(B) Consultant represents that the tasks and services required hereunder will be performed by Consultant or under its direct supervision, and that all personnel engaged in such work shall be fully qualified and shall be authorized and permitted under applicable State and local law to perform such tasks and services. Consultant will exclusively determine the means, methods and details of performing the services subject to the requirements of this Agreement.

(C) This Agreement contemplates the personal services of Consultant and Consultant's employees, and it is recognized by the parties hereto that a substantial inducement to City for entering into this Agreement was, and is, the professional reputation and competence of Consultant. Neither this Agreement nor any interest therein may be assigned by Consultant, except upon written consent of City.

1.8 Prohibition Against Subcontracting or Assignment. Consultant shall not contract with any other entity to perform in whole or in part the services required hereunder without the express written approval of City. In addition, neither the Agreement nor any interest herein may be transferred, assigned, conveyed, hypothecated, or encumbered voluntarily or by operation of law, whether for the benefit of creditors or otherwise, without the prior written approval of City. In the event of any unapproved transfer, including any bankruptcy proceeding, City may void the Agreement at City's option in its sole and absolute discretion. No approved transfer shall release any surety of Consultant of any liability hereunder without the express written consent of City.

SECTION TWO: INSURANCE AND INDEMNIFICATION

2.1 Insurance. Without limiting Consultant's indemnification obligations, Consultant shall procure and maintain, at its sole cost and for the duration of this Agreement, insurance coverage as provided below, against all claims for injuries against persons or damages to property which may arise from or in connection with the performance of the work hereunder by Consultant, its agents, representatives, employees, and/or subconsultants. In the event that Consultant subcontracts any portion of the work in compliance with Section 1.8 of this Agreement, the contract between the Consultant and such subconsultant shall require the subconsultant to maintain the same policies of insurance that the consultant is required to maintain pursuant to this Section 2.1.

2.1.1 Insurance Coverage Required. The Insurance obligations under this agreement shall be (1) all the Insurance coverage and/or limits carried by or available to the Consultant; or (2) the minimum Insurance coverage requirements and/or limits shown in

this agreement; whichever is greater. Any insurance proceeds in excess of or broader than the minimum required coverage and/or minimum required limits, which are applicable to a given loss, shall be available to the City. No representation is made that the minimum insurance requirements of this agreement are sufficient to cover the obligations of the Consultant under this agreement.

The policies and amounts of insurance required hereunder shall be as follows:

A. Comprehensive General Liability Insurance which affords coverage at least as broad as Insurance Services Office "occurrence" form CG 00 01 including completed operations and contractual liability, with limits of liability of not less than \$1,000,000 per occurrence and \$2,000,000 annual aggregate for liability arising out of Consultant's performance of this Agreement. The limits shall be provided by either a single primary policy or combination of policies. If limits are provided with excess and/or umbrella coverage the limits combined with the primary will equal the minimum limits set forth above. If written with an aggregate, the aggregate shall be double the each occurrence limit. Such insurance shall be endorsed to:

- (1) Name the City of Irvine and its employees, representatives, officers and agents (collectively hereinafter "City and City Personnel") as additional insured for claims arising out of Consultant's performance of this Agreement.
- (2) Provide that the insurance is primary and non-contributing with any other valid and collectible insurance or self-insurance available to City.

A statement on an insurance certificate will not be accepted in lieu of the actual endorsement.

B. Automobile Liability Insurance with a limit of liability of not less than \$1,000,000 each occurrence and \$1,000,000 annual aggregate. The limits shall be provided by either a single primary policy or combination of policies. If limits are provided with excess and/or umbrella coverage the limits combined with the primary will equal the minimum limits set above. Such insurance shall include coverage for all "owned," "hired" and "non-owned" vehicles, or coverage for "any auto." Such insurance shall be endorsed to:

- (1) Name the City of Irvine and its employees, representatives, officers and agents as additional insured for claims arising out of Consultant's performance of this Agreement.
- (2) Provide that the insurance is primary and non-contributing with any other valid and collectible insurance or self-insurance available to City.

A statement on an insurance certificate will not be accepted in lieu of the actual endorsement.

C. Workers' Compensation Insurance in accordance with the Labor Code of California and covering all employees of the Consultant providing any service in the performance of this agreement. Such insurance shall be endorsed to:

- (1) Waive the insurer's right of Subrogation against the City and City Personnel.

A statement on an insurance certificate will not be accepted in lieu of the actual endorsement unless your insurance carrier is the State of California Insurance Fund (SCIF) and the endorsement numbers 2570 and 2065 are referenced on the certificate of insurance.

Consultant's completion of the form attached hereto as Exhibit 1 shall be a condition precedent to Consultant's rights under this Agreement. Should Consultant certify, pursuant to Exhibit 1, that, in the performance of the work under this Agreement, it shall not employ any person in any manner so as to become subject to the workers' compensation laws of California, Consultant shall nonetheless maintain responsibility for requiring that any subconsultants performing work under this Agreement have and maintain workers' compensation insurance, as required by Section 3700 of the Labor Code, for the work performed under this Agreement.

D. Professional Liability Insurance with minimum limits of \$1,000,000 each claim. Covered professional services shall include all work performed under this Agreement and delete any exclusion that may potentially affect the work to be performed.

E. If the consultant maintains broader coverage and/or higher limits than the minimums shown above, the City requires and shall be entitled to the broader coverage and/or higher limits maintained by the consultant.

F. Evidence of Insurance: Consultant shall provide to City a Certificate(s) of Insurance evidencing such coverage together with copies of the required policy endorsements no later than five (5) business days prior to commencement of service and at least fifteen (15) business days prior to the expiration of any policy. Coverage shall not be suspended, voided, cancelled, reduced in coverage or in limits, non-renewed, or materially changed for any reason, without thirty (30) days prior written notice thereof given by the insurer to City by U.S. mail, or by personal delivery, except for nonpayment of premiums, in which case ten (10) days prior notice shall be provided.

The City project title or description MUST be included in the "Description of Operations" box on the certificate.

The City's insurance certificate tracking services provider, Exigis, LLC, will send Consultant an email message providing instructions for submitting insurance certificates and endorsements.

Certificate Holder:

City of Irvine, California
c/o: Exigis LLC
PO Box 4668 ECM #35050
New York, NY 10168-4668

G. Endorsements: A statement on an insurance certificate will not be accepted in lieu of the actual endorsement. Insurance policies shall not be in compliance if they include any limiting provision or endorsement that has not been submitted to the City for approval.

Additional Insured Endorsements shall not:

1. Be limited to "Ongoing Operations"
2. Exclude "Contractual Liability"

3. Restrict coverage to the "Sole" liability of Consultant
4. Contain any other exclusion contrary to the Agreement.

H. Any Deductible in Excess of \$100,000 and/or Self-Insured Retentions must be approved in writing by the City.

I. Acceptability of Insurers. Each policy shall be from a company with current A.M. Best's rating of A- VII or higher and authorized to do business in the State of California, or otherwise allowed to place insurance through surplus lines brokers under applicable provisions of the California Insurance Code or any federal law. Any other rating must be approved in writing by the City.

J. Insurance of Subconsultants. Consultant shall be responsible for causing Subconsultants to maintain the same types and limits of coverage in compliance with this Agreement, including naming the City as an additional insured to the Subconsultant's policies.

2.2 Indemnification. Consultant shall indemnify, defend, and hold City and City Personnel harmless from and against any and all actions, suits, claims, demands, judgments, attorney's fees, costs, damages to persons or property, losses, penalties, obligations, expenses or liabilities (herein "claims" or "liabilities") that may be asserted or claimed by any person or entity arising out of the willful or negligent acts, errors or omissions of Consultant, its employees, agents, representatives or subconsultants which directly or indirectly relate to the work being performed or services being provided under this Agreement, whether or not there is concurrent active or passive negligence on the part of City and/or City Personnel, but excluding such claims or liabilities arising from the sole active negligence or willful misconduct of City or City Personnel in connection therewith:

2.2.1 Consultant shall defend any action or actions filed in connection with any such claims or liabilities, and shall pay all costs and expenses, including attorney's fees incurred in connection therewith.

2.2.2 Consultant shall promptly pay any judgment rendered against City or any City Personnel for any such claims or liabilities.

2.2.3 In the event City and/or any City Personnel is made a party to any action or proceeding filed or prosecuted for any such damages or other claims arising out of or in connection with the work being performed or services being provided under this Agreement, Consultant shall pay to City any and all costs and expenses incurred by City or City Personnel in such action or proceeding, together with reasonable attorney's fees and expert witness fees.

These Indemnification provisions are independent of, and shall not in any way be limited by, the Insurance Requirements of this Agreement. City approval of the insurance contracts required by this Agreement does not in any way relieve the Consultant from liability under this section.

SECTION THREE: LEGAL RELATIONS AND RESPONSIBILITIES

3.1 Compliance with Laws. Consultant shall keep itself fully informed of all existing and future state and federal laws and all county and city ordinances and regulations which in any manner affect those employed by it or in any way affect the performance of services pursuant to this Agreement. Consultant shall at all times observe and comply with all such laws, ordinances,

and regulations and shall be responsible for the compliance of all work and services performed by or on behalf of Consultant. When applicable, Consultant shall not pay less than the prevailing wage, which rate is determined by the Director of Industrial Relations of the State of California.

3.2 Licenses, Permits, Fees and Assessments. Consultant shall obtain at its sole cost and expense all licenses, permits, and approvals that may be required by law for the performance of the services required by this Agreement. Consultant shall have the sole obligation to pay any fees, assessments, and taxes, plus applicable penalties and interest, which may be imposed by law and arise from or are necessary for Consultant's performance of the services required by this Agreement, and shall indemnify, defend, and hold harmless City against any such fees, assessments, taxes, penalties, or interest levied, assessed, or imposed against City thereunder.

3.3 Covenant against Discrimination. Consultant covenants for itself, its heirs, executors, assigns, and all persons claiming under or through it, that there shall be no discrimination against any person on account of race, religious creed, color, national origin, ancestry, physical disability, mental disability, medical condition, genetic information, marital status, sex, gender, gender identity, gender expression, age, sexual orientation, or military and veteran status of any person, in the performance of this Agreement. Consultant further covenants and agrees to comply with the terms of the Americans with Disabilities Act of 1990 (42 U.S.C. §12101 et seq.) as the same may be amended from time to time.

3.4 Independent Consultant. Consultant shall perform all services required herein as an independent consultant of City and shall remain at all times as to City a wholly independent consultant. City shall not in any way or for any purpose become or be deemed to be a partner of Consultant in its business or otherwise, or a joint venturer, or a member of any joint enterprise with Consultant. Consultant shall not at any time or in any manner represent that it or any of its agents or employees are agents or employees of City. Neither Consultant nor any of Consultant's employees shall, at any time, or in any way, be entitled to any sick leave, vacation, retirement, or other fringe benefits from the City; and neither Consultant nor any of its employees shall be paid by City time and one-half for working in excess of forty (40) hours in any one week. City is under no obligation to withhold State and Federal tax deductions from Consultant's compensation. Neither Consultant nor any of Consultant's employees shall be included in the competitive service, have any property right to any position, or any of the rights an employee may have in the event of termination of this Agreement.

3.5 Covenant against Contingent Fees. Consultant warrants that it has not employed or retained any company or person other than a bona fide employee working for Consultant, to solicit or secure this Agreement and that it has not paid or agreed to pay any company or person any fee, commission, percentage, brokerage fee, gift, or any other consideration contingent upon, or resulting from, the award or making of this Agreement. For breach or violation of this warranty, City shall have the right to annul this Agreement without liability or, in its discretion, to deduct from the Agreement price or consideration, or otherwise recover, the full amount of such fee, commission, percentage, brokerage fee, gift or contingent fee.

3.6 Use of Patented Materials. Consultant shall assume all costs arising from the use of patented or copyrighted materials, including but not limited to equipment, devices, processes, and software programs, used or incorporated in the services or work performed by Consultant under this Agreement. Consultant shall indemnify, defend, and save the City harmless from any and all suits, actions or proceedings of every nature for or on account of the use of any patented or copyrighted materials consistent with Section 2.2 herein.

3.7 Proprietary Information. All proprietary information developed specifically for City by Consultant in connection with, or resulting from, this Agreement, including but not limited to inventions, discoveries, improvements, copyrights, patents, maps, reports, textual material, or software programs, but not including Consultant's underlying materials, software, or know-how, shall be the sole and exclusive property of City, and are confidential and shall not be made available to any person or entity without the prior written approval of City. Consultant agrees that the compensation to be paid pursuant to this Agreement includes adequate and sufficient compensation for any proprietary information developed in connection with or resulting from the performance of Consultant's services under this Agreement. Consultant further understands and agrees that full disclosure of all proprietary information developed in connection with, or resulting from, the performance of services by Consultant under this Agreement shall be made to City, and that Consultant shall do all things necessary and proper to perfect and maintain ownership of such proprietary information by City.

3.8 Retention of Funds. Consultant hereby authorizes City to deduct from any amount payable to Consultant (whether arising out of this Agreement or otherwise) any amounts the payment of which may be in dispute hereunder or which are necessary to compensate City for any losses, costs, liabilities, or damages suffered by City, and all amounts for which City may be liable to third parties, by reason of Consultant's negligent acts, errors, or omissions, or willful misconduct, in performing or failing to perform Consultant's obligations under this Agreement. City in its sole and absolute discretion, may withhold from any payment due Consultant, without liability for interest, an amount sufficient to cover such claim or any resulting lien. The failure of City to exercise such right to deduct or withhold shall not act as a waiver of Consultant's obligation to pay City any sums Consultant owes City.

3.9 Termination by City. City reserves the right to terminate this Agreement at any time, with or without cause, upon written notice to Consultant. Upon receipt of any notice of termination from City, Consultant shall immediately cease all services hereunder except such as may be specifically approved in writing by City. Consultant shall be entitled to compensation for all services rendered prior to receipt of City's notice of termination and for any services authorized in writing by City thereafter. If termination is due to the failure of Consultant to fulfill its obligations under this Agreement, City may take over the work and prosecute the same to completion by contract or otherwise, and Consultant shall be liable to the extent that the total cost for completion of the services required hereunder, including costs incurred by City in retaining a replacement consultant and similar expenses, exceeds the Budget.

3.10 Right to Stop Work; Termination by Consultant. Consultant shall have the right to stop work and terminate only if City fails to timely make a payment required under the terms of the Budget. Consultant shall provide City thirty (30) day prior written notice of such claimed payment owed and City shall have an opportunity to remedy any such claimed breach during such time with no legal consequence to City. Consultant shall immediately cease all services hereunder following the thirty (30) day notice, except such services as may be specifically approved in writing by City. Consultant shall be entitled to compensation for all services rendered prior to termination and for any services authorized in writing by City thereafter. If Consultant terminates this Agreement because of an error, omission, or a fault of Consultant, or Consultant's willful misconduct, the terms of Section 3.9 relating to City's right to take over and finish the work and Consultant's liability shall apply.

3.11 Waiver. No delay or omission in the exercise of any right or remedy by a nondefaulting party with respect to any default shall impair such right or remedy or be construed as a waiver. A party's consent to or approval of any act by the other party requiring the party's consent

or approval shall not be deemed to waive or render unnecessary consent to or approval of any subsequent act. A waiver by either party of any default must be in writing.

3.12 Legal Actions. Legal actions concerning any dispute, claim, or matter arising out of or in relation to this Agreement shall be instituted and maintained in the Superior Courts of the State of California in the County of Orange, or in any other appropriate court with jurisdiction in such County, and Consultant agrees to submit to the personal jurisdiction of such court.

3.13 Rights and Remedies are Cumulative. Except as may be expressly set forth in this Agreement, the rights and remedies of the parties are cumulative and the exercise by either party of one or more of such rights or remedies or other rights or remedies as may be permitted by law or in equity shall not preclude the exercise by such party, at the same or different times, of any other rights or remedies to which such party may be entitled.

3.14 Attorneys' Fees. In any action between the parties hereto seeking enforcement of any of the terms or provisions of this Agreement or in connection with the performance of the work hereunder, the party prevailing in the final judgment in such action or proceeding, in addition to any other relief which may be granted, shall be entitled to have and recover from the other party its reasonable costs and expenses, including, but not limited to, reasonable attorney's fees, expert witness fees, and courts costs. If either party to this Agreement is required to initiate or defend litigation with a third party because of the violation of any term or provision of this Agreement by the other party, then the party so litigating shall be entitled to its reasonable attorney's fees and costs from the other party to this Agreement.

3.15 Force Majeure. The time period specified in this Agreement for performance of services shall be extended because of any delays due to unforeseeable causes beyond the control and without the fault or negligence of City or Consultant, including, but not restricted to, acts of nature or of the public enemy, unusually severe weather, fires, earthquakes, floods, epidemics, quarantine restrictions, riots, strikes, freight embargoes, wars, litigation, and/or acts of any governmental agency, including City, if the delaying party shall within ten (10) days of the commencement of such delay notify the other party in writing of the causes of the delay. If Consultant is the delaying party, City shall ascertain the facts and the extent of delay, and extend the time for performing the services for the period of the enforced delay when and if in the judgment of City such delay is justified. City's determination shall be final and conclusive upon the parties to this Agreement. In no event shall Consultant be entitled to recover damages against City for any delay in the performance of this Agreement, however caused. Consultant's sole remedy shall be extension of this Agreement pursuant to this Section 3.15.

3.16 Non-liability of City Officers and Employees. No officer, official, employee, agent, representative, or volunteer of City shall be personally liable to Consultant, or any successor in interest, in the event of any default or breach by City, or for any amount which may become due to Consultant or its successor, or for breach of any obligation of the terms of this Agreement.

3.17 Conflicts of Interest.

A. No officer, official, employee, agent, representative or volunteer of City shall have any financial interest, direct or indirect, in this Agreement, or participate in any decision relating to this Agreement that affects his or her financial interest or the financial interest of any corporation, partnership, association or other entity in which he or she is interested, in violation of any federal, state or city statute, ordinance or regulation. Consultant shall not employ any such person while this Agreement is in effect.

B. Consultant represents, warrants and covenants that he, she or it presently has no interest, direct or indirect, which would interfere with or impair in any manner or degree the performance of Consultant's obligations and responsibilities under this Agreement. Consultant further agrees that while this Agreement is in effect, Consultant shall not acquire or otherwise obtain any interest, direct or indirect, that would interfere with or impair in any manner or degree the performance of Consultant's obligations and responsibilities under this Agreement.

C. Consultant acknowledges that pursuant to the provisions of the Political Reform Act (Government Code section 87100 *et seq.*), City may determine Consultant to be a "Consultant" as that term is defined by the Act. In the event City makes such a determination, Consultant agrees to complete and file a "Statement of Economic Interest" with the City Clerk to disclose such financial interests as required by City. In such event, Consultant further agrees to require any other person doing work under this Agreement to complete and file a "Statement of Economic Interest" to disclose such other person's financial interests as required by City.

3.18 Consultant Ethics. Consultant represents and warrants that it has not provided or promised to provide any gift or other consideration, directly or indirectly, to any officer, employee, or agent of City to obtain City's approval of this Agreement. Consultant shall not, at any time, have any financial interest in this Agreement or the project that is the subject of this Agreement other than the compensation to be paid to Consultant as set forth in this Agreement. In the event the work and/or services to be performed hereunder relate to a project and/or application under consideration by or on file with the City, (i) Consultant shall not possess or maintain any business relationship with the applicant or any other person or entity which Consultant knows to have a personal stake in said project and/or application, (ii) other than performing its work and/or services to City in accordance with this Agreement Consultant shall not advocate either for or against said project and/or application, and (iii) Consultant shall immediately notify City in the event Consultant determines that Consultant has or acquires any such business relationship with the applicant or other person or entity which has a personal stake in said project and/or application. The provisions in this Section shall be applicable to all of Consultant's officers, directors, employees, and agents, and shall survive the termination of this Agreement.

3.19 Compliance with California Unemployment Insurance Code Section 1088.8. If Consultant is a Sole Proprietor, then prior to signing the Agreement, Consultant shall provide to the City a completed and signed Form W-9, Request for Taxpayer Identification Number and Certification. Consultant understands that pursuant to California Unemployment Insurance Code Section 1088.8, the City will report the information from Form W-9 to the State of California Employment Development Department, and that the information may be used for the purposes of establishing, modifying, or enforcing child support obligations, including collections, or reported to the Franchise Tax Board for tax enforcement purposes.

3.20 CalPERS Annuitants. If Consultant is a California Public Employees' Retirement System ("CalPERS") annuitant, Consultant must provide the City with written notification of such fact a minimum of 14 calendar days prior to commencement of services under this Agreement. Failure to provide such notification may result in termination of the Agreement, and any penalties or other costs relating thereto shall be borne by Consultant. If this Agreement remains in place, Consultant shall execute any amendment(s) to this Agreement requested by the City in order to comply with all laws and regulations applicable to CalPERS annuitants.

SECTION FOUR: MISCELLANEOUS PROVISIONS

4.1 Records and Reports. The City Manager of the City of Irvine or his/her designee reserves the right to perform such audits, performance reviews, and other evaluations (collectively 'audit') that relate to or concern this Agreement at any time. Consultant agrees to participate and cooperate in up to five (5) hours of meetings and interviews (at no additional cost to City), if the same are requested by the City in connection with such an audit. Further, provided that the City pays Consultant's commercially reasonable hourly rate for services, Consultant agrees to participate and cooperate in such additional meetings and interviews (in excess of five (5) hours), if the same are requested by the City in connection with such an audit. Upon request by City, Consultant shall prepare and submit to City any reports concerning Consultant's performance of the services rendered under this Agreement. City shall have access, with 72 hours advance written notice delivered to Consultant, to the books and records of Consultant related to Consultant's performance of this Agreement in the event any audit is required. All drawings, documents, and other materials prepared by Consultant in the performance of this Agreement (i) shall be the property of City and shall be delivered at no cost to City upon request of City or upon the termination of this Agreement, and (ii) shall not be made available to any individual or entity without prior written approval of City. The obligations of this Section 4.1 shall survive the expiration (or earlier termination) of this Agreement for a period of three (3) years. During said three (3) year period, Consultant shall keep and maintain all records and reports related to this Agreement, and City shall have access to such records in the event any audit is required.

4.2 Notices. Unless otherwise provided herein, all notices required to be delivered under this Agreement or under applicable law shall be personally delivered, or delivered by United States mail, prepaid, certified, return receipt requested, or by reputable document delivery service that provides a receipt showing date and time of delivery. Notices personally delivered or delivered by a document delivery service shall be effective upon receipt. Notices delivered by mail shall be effective at 5:00 p.m. on the second calendar day following dispatch. Notices to the City shall be delivered to the following address, to the attention of the City Representative set forth in Paragraph D.1 of the Fundamental Terms of this Agreement:

<u>To City:</u>	City of Irvine One Civic Center Plaza (92606) (Hand Deliveries) P. O. Box 19575 Irvine, CA 92623-9575
-----------------	--

Notices to Consultant shall be delivered to the address set forth below Consultant's signature on Part I of this Agreement, to the attention of Consultant's Representative set forth in Paragraph D.2 of the Fundamental Terms of this Agreement. Changes in the address to be used for receipt of notices shall be effected in accordance with this Section 4.2.

4.3 Construction and Amendment. The terms of this Agreement shall be construed in accordance with the meaning of the language used and shall not be construed for or against either party by reason of the authorship of this Agreement or any other rule of construction which might otherwise apply. The headings of sections and paragraphs of this Agreement are for convenience or reference only, and shall not be construed to limit or extend the meaning of the terms, covenants and conditions of this Agreement. This Agreement may only be amended by the mutual consent of the parties by an instrument in writing.

4.4 Severability. Each provision of this Agreement shall be severable from the whole. If any provision of this Agreement shall be found contrary to law, the remainder of this Agreement shall continue in full force.

4.5 Authority. The person(s) executing this Agreement on behalf of the parties hereto warrant that (i) such party is duly organized and existing, (ii) they are duly authorized to execute and deliver this Agreement on behalf of said party, (iii) by so executing this Agreement, such party is formally bound to the provisions of this Agreement, and (iv) the entering into this Agreement does not violate any provision of any other Agreement to which said party is bound.

4.6 Special Provisions. Any additional or supplementary provisions or modifications or alterations of these General Provisions shall be set forth in Part III of this Agreement ("Special Provisions").

4.7 Precedence. In the event of any discrepancy between Part I ("Fundamental Terms"), Part II ("General Provisions"), Part III ("Special Provisions"), Part IV ("Scope of Services"), and/or Part V ("Budget") of this Agreement, the order of precedence shall be as follows.

- Part III
- Part II
- Part IV
- Part V
- Part I

PART III

SPECIAL PROVISIONS

- 1) **Business License Requirement.** Consultants who provide services for the City of Irvine within the city limits of Irvine shall obtain, within five (5) days of executing this Agreement and prior to commencing any work herein, a City of Irvine business license and shall maintain a current business license throughout the term of this Agreement.
- 2) **Insurance Requirements.** PART II GENERAL PROVISIONS, Section 2.1.1 – B Automobile Liability Insurance and Section 2.1.1 - D. Professional Liability Insurance, are deleted in their entirety.
- 3) **Live Scan Fingerprinting Requirements.** Prior to commencing services, Consultants are required to successfully pass a Department of Justice fingerprinting background check (“Live Scan”) performed by a certified fingerprinting service provider or at the City of Irvine Police Department. The Consultant shall be responsible for obtaining the Live Scan for its staff and shall bear the cost thereof. The agency completing the fingerprints must provide the City of Irvine Human Resources with the background check results and subsequent records for review. Consultants must obtain a Consultant’s badge issued by the City of Irvine Human Resources prior to performing work.

PART IV

SCOPE OF SERVICES

**Services shall be performed as set forth below and in accordance with ATTACHMENT I.
(To be inserted after contract award.)**

PART V

BUDGET

Pricing shall be as set forth below and in accordance with ATTACHMENT II. (To be inserted after contract award.)

Included in the total compensation are all ordinary and overhead expenses incurred by Consultant and its agents and employees, including meetings with City representatives, and incidental costs incurred in performing under this Agreement. The total compensation for the Scope of Services set forth herein **shall not exceed \$ _____ annually**, including all amounts payable to Consultant for its overhead, payroll, profit, and all costs of whatever nature, including without limitation all costs for subcontracts, materials, equipment, supplies, and costs arising from or due to termination of this Agreement.

No work shall be performed in connection with this Agreement until the receipt of a signed City of Irvine Purchase Order; and no work shall be performed with a value in excess of the Purchase Order amount as the City has not authorized nor is it obligated to pay Consultant any such excess amount.

In the event Consultant anticipates the potential need to perform services beyond those set forth herein where additional funding may be needed, Consultant shall notify City in writing allowing sufficient time for City to consider further action.

Payment for services will be made monthly on invoices deemed satisfactory to the City, with payment terms of net 30 days upon receipt of invoice. Consultant shall submit invoices within fifteen (15) days from the end of each month in which services have been provided. Consultant shall provide invoices with sufficient detail to ensure compliance with pricing as set forth in this Agreement. The information required may include: date(s) of work, hours of work, hourly rate(s), and material costs.

The Purchase Order number must be included on all invoices, along with the City Representative's name. Failure to include this information on the invoice shall result in the return of the unpaid invoice.

Consultants should submit invoices electronically to: **invoicesubmittal@cityofirvine.org**

Payment by City under this Agreement shall not be deemed as a waiver of the City's right to claim at a later point that such payment was not due under the terms of this Agreement.

Pricing shall remain firm for the entire first term of the Agreement. Thereafter, any proposed pricing adjustment for follow-on renewal periods shall be submitted to the City Representative in writing at least ninety (90) days prior to the new Agreement term. The City reserves the right to negotiate any proposed pricing adjustment not to exceed the Bureau of Labor Statistics Consumer Price Index (CPI) data as follows: Los Angeles-Long Beach-Anaheim, CA; All Urban Consumers; Not Seasonally Adjusted; annualized change comparing the most recent month's reported data to the same month of the prior year. (This information may be found on the U.S. Department of Labor's website at www.bls.gov.)

Exhibit 1

WORKERS' COMPENSATION INSURANCE CERTIFICATION

Consulting Services Description: Public Safety CAD/RMS Mobile Software Replacement

WORKERS' COMPENSATION DECLARATION

I hereby affirm under penalty of perjury one of the following declarations:

(CHECK ONE APPLICABLE BOX BELOW)

I have and will maintain workers' compensation insurance, as required by Section 3700 of the Labor Code, for the performance of the work to be performed under this Agreement and shall submit insurance certificates evidencing such coverage as set forth herein.

I certify that, in the performance of the work under this Agreement, **I shall not employ any person** in any manner so as to become subject to the workers' compensation laws of California, and I hereby agree to indemnify, defend, and hold harmless the City of Irvine and all of its officials, employees, and agents from and against any and all claims, liabilities, and losses relating to personal injury or death, economic losses, and property damage arising out of my failure to provide such worker's compensation insurance. I further agree that, **if I should become subject to the workers' compensation provisions of Section 3700 of the Labor Code, I shall forthwith comply with those provisions and immediately furnish insurance certificates** evidencing such coverage as set forth herein.

WARNING: FAILURE TO SECURE WORKERS' COMPENSATION COVERAGE IS UNLAWFUL, AND SHALL SUBJECT AN EMPLOYER TO CRIMINAL PENALTIES AND CIVIL FINES UP TO ONE HUNDRED THOUSAND DOLLARS (\$100,000), IN ADDITION TO THE COST OF COMPENSATION, DAMAGES AS PROVIDED FOR IN SECTION 3706 OF THE LABOR CODE, INTEREST, AND ATTORNEY'S FEES.

Dated:	
Contracting Firm:	
Signature:	
Title:	
Address:	

ATTACHMENT III

PRICING PROPOSAL MATRIX (See attached Excel Spreadsheet)

ATTACHMENT IV

CITY TECHNOLOGY STANDARDS

The City maintains a segmented Public Safety Network (“PSN”) operated by the Information Technology (“IT”) Department. The IT Department has established general standards and best practices for the components that make up the various systems deployed with Public Safety as follows;

Network Environment: A segmented public safety network is maintained and operated by the IT Department. Each agency within the public safety network is further isolated into VLAN’s into two functional disciplines, Police and Communications, to ensure access to protect data is secure. I.e., CJIS data vs HIPAA data, etc.

The segments and VLAN’s are isolated behind SonicWALL Firewalls (“FW”). The PSN has interconnections with other public safety agencies locally and at the County and State via many different mediums including VPN, Point-to-Point and LAN-to-LAN connections. All layer three switches are VDX 6740/7750 and ICX 6610 series Enterprise-Class Brocade Switches. All firewalls are SonicWALL SRA Series 4600 firewalls.

Network Access and Security: The City has deployed as its standard, Microsoft Enterprise Endpoint Protection, to impose two standards that encompass security on desktop computers, mobile computers and servers. Desktop and mobile computers require Microsoft’s Windows Defender Security Center software to be loaded. This software acts as the anti-virus and malware software. Also required is Windows Defender Security Center on all servers that serve information to computers such as a file server.

Users are authenticated on both stationary desktop computers and mobile computers by Windows Active Directory. For stationary desktop computers, user’s login using the standard Windows login and once the user’s credentials are verified; the user arrives at the Windows desktop.

MDC traffic is using Windows 10 OS firewall and encrypted by NetMotion using 256 AES encryption. Generated traffic is sent across the commercial wireless carrier (Verizon and AT&T) to the PSN through a dedicated circuit into Cisco routers. The routers are then connected to the CAD VLAN segment which has access to the Cal DOJ CLETS via a Point-To-Point connection. The CAD system has access to the same VLAN via the COM router server.

The Cal DoJ CLETS information is accessed via the CAD server by an MDC via the CAD client. NetMotion client is used to encrypt/decrypt the communications between the MDC and CAD VLAN. No CLETS data is stored on the MDC hard drives.

MDC, Tablet and Smartphone users will utilize NetMotion Mobility Client to secure a VPN connection via the agency’s wireless network provider, Verizon and AT&T, with the agency’s secured network for accessing the CLETS. NetMotion works in conjunction with a CJIS compliant 2-factor authentication provider, Rapid Identity (formerly 2FA) using RFID cards in

combination with NetMotion to accomplish “something you know”; username and password, with “something you have”; an access card.

There is a tertiary authentication that occurs between the MDC, AD, Microsoft Certificate Authority (“CA”), and Microsoft RADIUS. This authentication is called machine authentication. After the computer joins the Domain, the computer object in Active Directory is moved to the appropriate Organizational Unit (“OU”). The object then authenticates against RADIUS and the CA issues a valid certificate. This entrusts that the computer that has VPN access through NetMotion identifies as an authorized computer to then access network resources.

Time Synchronization: The City synchronizes system time to an NTP server. Windows utilizes a time service called ‘Windows Time’, which is automatically installed in the service list. The program executable is ‘w32time.exe’. The service is installed and enabled by default during installation.

Windows Domain Networking is deployed, and only the Primary Domain Controller (PDC) synchronizes with the time reference. All other servers and workstations in the domain sync to the PDC using Windows proprietary protocol. The default installation procedure automatically configures workstations and servers to sync to the controlling PDC. Only the PDC needs to be configured to synchronize to an external time reference. The City currently sync to the following url: north-america.pool.ntp.org.

All servers, workstations, MDCs and Brocade/Cisco network equipment are setup to sync with the City’s PDC. Mobile devices like phones and tablets use the cellular provider network to sync their clocks.

NetMotion Mobility: By F-Secure Corporation (NIST Cert# 237, 441, & 493, FIPS 140-2 Certified) provides the secure VPN tunnel with end-to-end security standards-based encryption to FIPS 140-2 validated AES encryption.

Software Updates: The IT Department utilizes Microsoft’s System Center Configuration Manager to deploy software to each desktop computer, mobile computer and server on the network. IT uses the same software to provide operating system software updates to these resources as well. IT defines this process as “Patch Tuesday” in which updates are sent out to affected systems that receive the updates once a month. When a threat is recognized prior to the standard Patch Tuesday interval, IT staff triggers the system to perform the update at that time, rather than waiting for the next Patch Tuesday.

Desktop Hardware and Operating System Software: The City standardizes with Dell Optiplex Desktop computers with Windows 7 Pro-64-bit, Windows 8.1, and Windows 10. The City is phasing out older Lenovo desktop computers. The PC should have a minimum Intel Core i5 3.2GHz processor, 8 GB of RAM, a 500 GB HDD and a DVDRW. Each computer is equipped with Dell/Lenovo monitors varying from 17 inch to 24 inch models.

The City replaces desktop computers on a 5-year cycle and the monitors on an as needed basis. For the purpose of the CAD, RMS and Mobile Replacement Project, the City has held off replacing the hardware within the Communication Center until a Consultant has been selected and specific requirements are determined.

Server Hardware and Operating System Software: The City standardizes with Dell FX/FC hosts and Hyper-V software for the virtual servers. The servers' operating system ranges from Microsoft Windows 2008 to 2016.

The City replaces physical servers on a 7-year cycle. For the purpose of the CAD, RMS and Mobile Replacement Project, the City has held off replacing the hardware for CAD servers and ancillary interface servers until a Consultant has been selected and specific requirements are determined.

Mobile Hardware and Operating System Software: The standard hardware is the Panasonic CF-33 Rugged Tablet; 12in Display, 5MP Camera, Intel i5-6300U 2.4GHz Processor, 16GB RAM, 500GB SSD, 1200 NITs Touchscreen Display, Dual batteries, 5MP camera, 802.11AC Wireless, Bluetooth, TPM, GPS built in receiver, 4G.LTE Broadband (Multi Carrier). Each tablet is configured to run Windows 10 enterprise 64-bit. BitLocker provides full disk encryption.

The City replaces mobile computers on a 7-year cycle. For the purpose of the CAD, RMS and Mobile Replacement Project, the City requires the Consultant to ensure their mobile applications are capable of being installed and perform as designed without any degradation.

Mobile Smartphone's: The City standardizes on Apple iPhone 7x and 8x with an iOS operating system.

Mobile Device Management ("MDM"): The City utilizes Microsoft Intune cloud-based enterprise mobility management software as an MDM for all mobile devices. Microsoft Intune provides over-the-air centralized management, diagnostics, and monitoring for the mobile devices managed by the City. The City primarily uses Microsoft Intune for Cell Phones. Microsoft Intune monitors each device, showing useful metrics such as client hardware/software information, location of each device, and remote lock and erase devices. The following is the extent to which Microsoft Intune is utilized by the city; push applications to devices, manage user mail exchange credentials, track location of lost devices, and remote lock or wipe of stolen devices.

Back-Up and Recovery Software and Process: The City currently backs up the existing CAD and RMS system using Carbonite's eVault solution. The method of backup is disk to disk to cloud backups. The data is stored on the City's eVault appliances located at the City Hall datacenter and identical copies are sent to the cloud for offsite storage.

City Telephone System: The City has deployed a Voice over Internet Protocol ("VoIP") enterprise telephone system from Cisco. The system utilizes the Cisco Call Manager version 11. The Cisco system is locally hosted on a virtual server and utilizes PRI trunks. The system is SIP compatible and provides legacy analog functionality. The Cisco system supports 500+ phones for the City, to include standard features such as voicemail, call forwarding, conference calling and more.

ATTACHMENT V

CITY GIS STANDARDS

Hardware: GIS maintains a total of six virtual servers. One each staging and production SQL Servers, three web servers (one staging) and one test server.

Software: ESRI based application platform for server and client side access. Inventory includes Server based products: ArcGIS Server Enterprise (Enterprise Geodatabase for MS SQL, ArcGIS Server), and client based desktop ArcGIS. Desktop licensing is concurrent for multi-user access. Twelve concurrent advanced licenses and nine concurrent Basic. Two Single Use.

Data: GIS maintains vector and raster data. Raster data are mainly ortho-images which date back as early as 1976, and images that cover most of the years from 2000 to 2017.

Processes: Irvine GIS currently utilizes ArcMap to publish a variety of Map Services for internal and external use. Public Safety has its own GIS staff who manage the police related data while Irvine GIS manages the City GIS data.

Personnel: The GIS division has 4 full time employees, 1 part-time and 2 interns.

Theme	Description Frame Work Layers	Type	SDE
Parcels	GIS staff maintains the parcel in-house after the parcels are recorded by the County of Orange. Ownership updates provided by Parcel Quest.	Vector	Y
City Boundary	Irvine Incorporation Boundary	Vector	Y
Building Footprint	Building footprints used for addressing, etc.	Vector	Y
Aerial Imagery	Aerial imagery of the City at various resolution from 1976 to 2017	Raster	Y
Street Centerline	Single carriage way road network, with public and private roadways. Also provides address ranges for geo-coding events linked to addresses	Vector	Y
County Centerlines	Street data that falls outside the City Limits in surrounding areas	Vector	Y
Public Safety Areas	These are police areas, beats and ESZ's	Vector	Y
Address points	Points created from the addresses in building footprints	Vector	Y