

## 1. COVER LETTER

Ronda Miller, Services Purchasing  
State of Nevada, Purchasing Division  
515 E. Musser Street, Suite 300  
Carson City, NV 89701

May 3, 2011

RE: RFP 1901, Inmate Kiosks

Dear Ms. Miller:

JPay Inc. ("JPay") is pleased to submit this response to Request for Proposal No. 1901 for Inmate Kiosks ("RFP") on behalf of the members of the National Association of State Procurement Officials and the Multi-State Corrections Procurement Alliance (referred to collectively as the "DOC").

The JPay team has carefully reviewed the RFP and believes that we can meet and often exceed the requirements set forth in the RFP to provide a holistic inmate kiosk solution for automating everyday inmate services.

By selecting JPay, the DOC will be partnering with a company that is in full control of its product – from design to development to implementation. JPay's products are built and maintained by JPay employees who take tremendous pride in their work. As a team, we are excited to offer these services to the DOC.

The enclosed Technical Proposal has been provided to all requesting State Evaluators.

Sincerely,



Errol Feldman  
12864 Biscayne Blvd. Suite 243  
Miami, FL 33181  
Tel: 305.577.5543  
Fax: 305.893.8985  
Email: [efeldman@jpay.com](mailto:efeldman@jpay.com)

## 2. EXECUTIVE SUMMARY

JPay Inc. appreciates the opportunity to submit our proposed solution to the State of Nevada Purchasing Division on behalf of National Association of State Procurement Officials (NASPO) and the Multi-State Corrections Procurement Alliance (MCPA) Request for Proposal No.1901 for Inmate Kiosks.

JPay is not a commissary company nor is it an inmate telephone company. We are a software company focused on building and delivering innovative inmate service applications. We believe these applications are a separate category of products that traditional correctional companies can only attempt to deliver.

JPay's turnkey kiosk applications, designed developed and maintained in house, include digital music delivery, Internet video visitation, inmate banking, inmate email, commissary ordering and other various custom applications requested over time by our correctional partners. Each application is available on the inmate kiosk which is available in every housing unit, eliminating the need to move inmates and increasing inmate adoption exponentially.

Today, JPay contracts with over 21 state correctional agencies and numerous county jails and private prison operators. This translates to a footprint of over 1.2 million inmates, half the nation's inmate population. By providing exceptional customer service and a superior product, the company continues to be the first choice for correction personnel, inmates and their friends and family.

JPay is eager for the opportunity to provide its services for the DOC.

### *Why JPay*

#### *A better model...*

- *At least one kiosk is installed in each housing unit at every facility*
- *Each inmate application is available on every single kiosk*
- *Every inmate at all custody levels has access to the services*

*The difference: an exponentially higher adoption rate*

### 3. SCOPE OF WORK

#### 3.1 KIOSKS

##### 3.1.1 Kiosk Solutions

*3.1.1.1 Turnkey Kiosks - all hardware and software necessary to provide any related services the vendor provides.*

The JPay Team has read, understands and agrees to comply.

*3.1.1.2 Stand Alone Kiosk - all hardware and software necessary to provide unattended transaction processing of applications.*

The JPay Team has read, understands and agrees to comply.

*3.1.1.3 Outside Kiosk - located outside and be able to withstand weather and the elements; rain, snow, wind, sun, etc. Kiosks should withstand temperatures from -20 degrees to 110 degrees with up to 100% humidity.*

The JPay Team has read, understands and agrees to comply.

*3.1.1.4 Hardware Only Kiosk - all related hardware as needed to implement kiosk solution. Kiosk should contain a touch screen; however, a durable security centered keyboard will also be considered especially supporting disabled inmates who could not access the kiosks.*

The JPay Team has read, understands and agrees to comply.

### 3.1.2 Kiosk Enclosure

*The successful vendor shall provide a kiosk design to be of standalone style for inside/outside locations. The kiosk enclosure/housing needs to be self contained, rugged and secure. No crevices that can enable inmates to damage or spill into the enclosure and damage the kiosk. This requirement is not mandatory and will be determined by the type of kiosk proposed. If there are no enclosures, vendors are to explain in detail the plan for mounting and security of the hardware.*

The JPay Team has read, understands and agrees to comply.

Inmate kiosks, whether indoor or outdoor, are built solely for correction environments with a security first approach. The kiosks are enclosed with a steel case and security screws, making them virtually impossible to break into. Both kiosks have a 17" LCD monitor mounted behind 1/4" security tempered glass. The embedded keyboard is vandal resistant and spill proof and the impact resistant track ball is made of stainless steel. The kiosk also features a protected web camera and phone handset with armored cable. Outdoor kiosks are protected from the elements with a cooling and heating system that protects the various hardened components.

*Kiosk enclosures may, but not limited to the following:*

*3.1.2.1 Heavy duty locking mechanisms, hinges, door mechanisms capable of resisting inmate tampering and vandalism.*

The JPay Team has read, understands and agrees to comply.

*3.1.2.2 Hardware must be contained in the kiosk enclosure.*

The JPay Team has read, understands and agrees to comply.

*3.1.2.3 The kiosk should have the ability to be anchored to the floor and or the wall. The vendor shall ensure that each kiosk can be easily unsecured from the floor or the wall by authorized personnel.*

The JPay Team has read, understands and agrees to comply.

*3.1.2.4 The kiosk enclosure must be of a neutral color and easily cleaned.*

The JPay Team has read, understands and agrees to comply.

3.1.2.5 The kiosk shall not bear company names or logos.

The JPay Team has read, understands and agrees to comply.

3.1.2.6 Pictures, artist renderings and drawings of the proposed kiosk design shall be included with the proposal.

**Inmate Kiosk - Indoor**

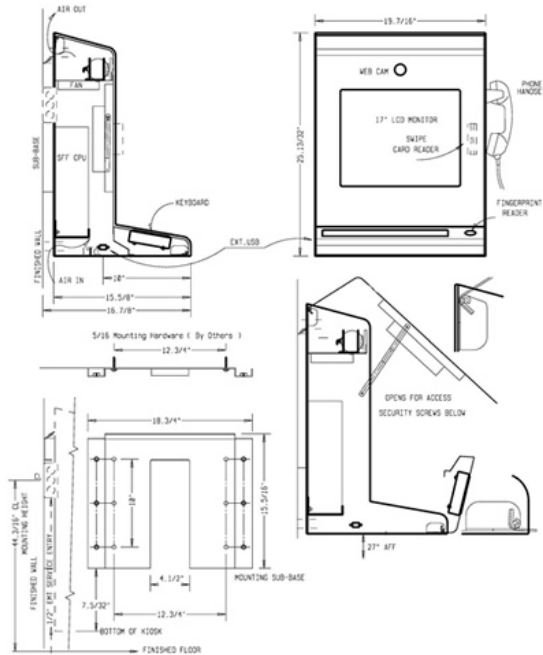

**Inmate Kiosk - Outdoor**

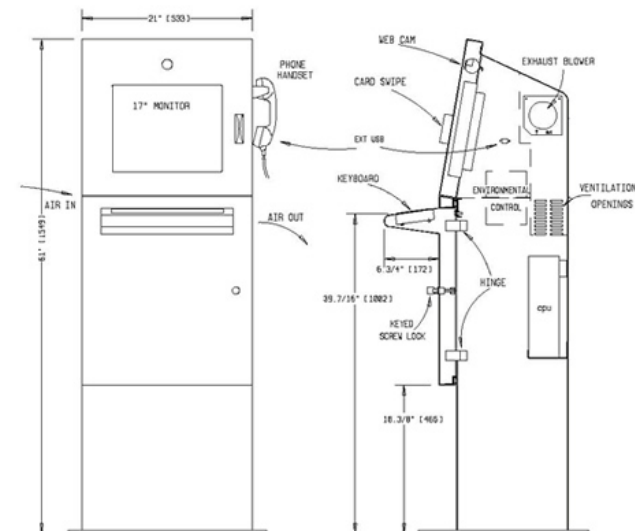

*3.1.2.7 Vendor must ensure that battery-backed alarms with detectors on all openings are implemented where entry might be forced. Kiosk alarms must be:*

The JPay Team has read, understands and agrees to comply.

*Manually set to ring for a period of time with shrill alarm;*

The JPay Team has read, understands and agrees to comply.

*Capable of activation/deactivation at a remote location designated by the institution; and*

The JPay Team has read, understands and agrees to comply.

*Proven not to provide false signaling regarding remote alarm.*

The JPay Team has read, understands and agrees to comply.

JPay runs a Network Operations Center (“NOC”) and a set of deployment mechanisms that allow JPay to remotely disable or reboot a kiosk or any other hardware JPay deploys to provide the services.

*3.1.2.8 Kiosks must have sealed opening(s) for power and phone lines as needed.*

The JPay Team has read, understands and agrees to comply.

*3.1.2.9 Kiosks have adequate ventilation to include fans if needed for components.*

The JPay Team has read, understands and agrees to comply.

## 3.2 TECHNICAL ENVIRONMENT

### 3.2.1 Kiosk Applications

*At a minimum, the operating system/applications should allow the Participating States DOC the ability to modify. Vendor shall ensure each kiosk is maintained on the most current version of the vendor's systems of operation, with no more than two versions at any one-time across all kiosks.*

The JPay Team has read, understands and agrees to comply.

The kiosk uses a Dell PC and runs on Microsoft® Windows XP. Each application is built solely to run on this platform. If modifications are necessary for any participating state, JPay will configure its product to meet the DOC's needs.

*Vendor shall provide the method of insuring inmate ID security. Methods could include fingerprint scan, or other biometric possibilities, ID card scanning (magnetic or barcode), and or voice options.*

The JPay Team has read, understands and agrees to comply.

Each JPay kiosk is equipped with a swipe card reader. To access the kiosk, inmates must swipe their ID and then enter their username and password. All inmates must register before using the kiosk. Upon initial log in, JPay's system provides the inmate with a unique password. Inmates are then required to change their password, and have an option to reset their passwords if forgotten.

JPay can also install fingerprint scanners on each kiosk and develop a fingerprint registration process that will ensure the highest levels of accessibility to the kiosk. However, the standard method for accessing the kiosk today is via a card swipe as described above.

#### 3.2.1.1 Email/Secure Messaging

*Incoming/outgoing is screened by the system using keyword search before download is allowed. Keyword screening would evaluate risk level of e-mail. Unacceptable or questionable (moderate to high risk) e-mail is held or staged at a central location computer for DOC approval before it is available for offender delivery or download. At minimum; Keyword search may be edited at any time. Offender email must be storable by vendor or transferrable to DOC Storage.*

The JPay Team has read, understands and agrees to comply.

Over the years, JPay’s security-driven eMessaging system has grown to become the most feature-rich and widely adopted inmate email system in corrections. Today, JPay provides eMessaging to 15 state prison systems across the country including the Texas Department of Criminal Justice, the largest correctional client in the country.

The service provides unparalleled security and intelligence capabilities and enhances the work of investigative personnel, making for safer and better-run facilities. DOC staff access the eMessaging program through JPay’s secure web portal, called the Facility System. This site can be accessed from any computer or mobile device connected to the Internet.

The process begins with the screening process:

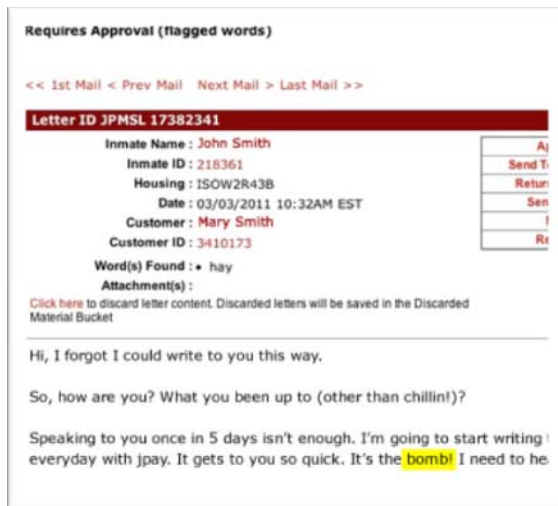

When a customer or inmate sends an eMessage, it is automatically scanned and categorized according to rules put in place by the DOC. The DOC can pre-populate watch lists with words, key phrases or character strings that flag and restrict the letter from being sent until it is reviewed. In addition, if an eMessage contains an attachment (or more than one) it is flagged and forced to be viewed before it is sent to the recipient.



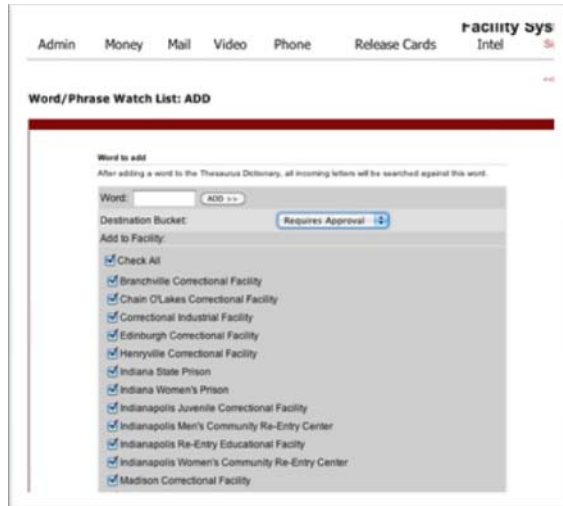

Staff manages the word dictionary and the user watch lists. All changes to the dictionaries and user lists occur in real time and are populated to the entire user base immediately. Entire dictionaries, single words or phrases, suspicious inmates or customers Bucket can all be shared with each facility or transferred to one region or one facility.

All eMessages are stored in a secure database and available on JPay's Facility System. Historical eMessages are available on the Facility System for 3 years and maintained offline indefinitely thereafter. If data is offline, DOC staff simply requests the information and JPay will deliver it within one to two business days.

*3.2.1.1.1 Email services, including, restrictions of senders/receivers, and keyword search capabilities on both incoming and outgoing messages. Please give your ability to provide the above.*

The JPay Team has read, understands and agrees to comply.

eMessages containing words, senders or recipients on a watch list are categorized according to their content as described above. Once an eMessage is flagged, it is held in a pending message box and cannot be distributed to the inmate until it is approved by the DOC. For security purposes, all eMessages containing an attachment are automatically held until manually approved. If an eMessage goes through the screening process and is not flagged by a watch list, the eMessage sits in

a “Ready to Deliver” message box until it is released to the inmate.

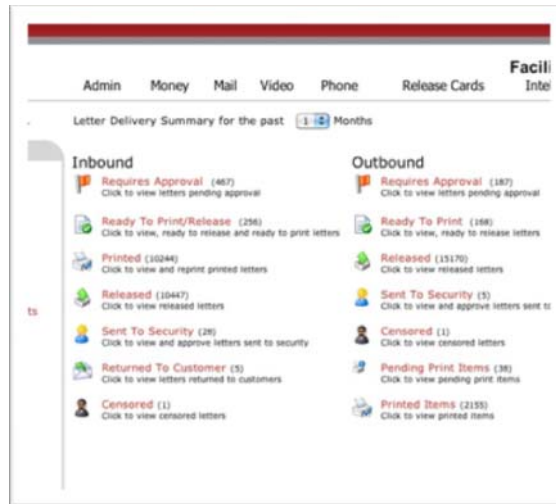

Examples of why an eMessage would be flagged and require review:

- Flagged by word dictionary
- Flagged by inmate or sender watch list
- Contains an attachment

The DOC user can either release the eMessage to the recipient or request additional review. In addition, the eMessage or attachment can be indefinitely detained, returned to sender or discarded entirely. The DOC even has the option to notify the sender if the eMessage was discarded.

If only part of an eMessage contains inappropriate content, the DOC can discard the attachment or content and release the remaining portion of the eMessage to the inmate. Although material is discarded, it is stored in JPay’s system indefinitely and can be accessed by the DOC anytime.

Individual customers and inmates considered to be abusing their privilege of eMessaging can be restricted from using the service.









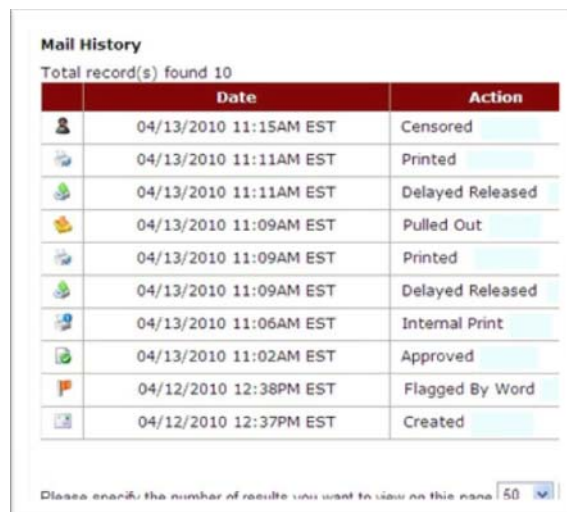

*3.2.1.1.2 Capability for the DOC to manage email approvals at either an institution level as well as a state level.*

The JPay Team has read, understands and agrees to comply.

Different levels of access can be granted to Facility System users based on their role in the institution or central office. Permissions range from per facility, region or system-wide. “Superusers” have access to all facilities for example, while facility users may only access their facility’s data.

A DOC user can look up an eMessage’s history to view all actions related to the message. This function lets supervisors audit mailroom staff. If an eMessage is mistakenly approved, the mailroom supervisor can view the message’s history and identify which staff member approved it. Without this audit trail, it would be virtually impossible to maintain a securely run eMessaging system.



	Date	Action
	04/13/2010 11:15AM EST	Censored
	04/13/2010 11:11AM EST	Printed
	04/13/2010 11:11AM EST	Delayed Released
	04/13/2010 11:09AM EST	Pulled Out
	04/13/2010 11:09AM EST	Printed
	04/13/2010 11:09AM EST	Delayed Released
	04/13/2010 11:06AM EST	Internal Print
	04/13/2010 11:02AM EST	Approved
	04/12/2010 12:38PM EST	Flagged By Word
	04/12/2010 12:37PM EST	Created

Please specify the number of results you want to view on this page: 50

All eMessages are tracked and each action is recorded. eMessage history is available for every message and attachment that is processed in the system and each transaction can be clearly identified.

*3.2.1.1.3 Systems ability for the email to include photos. System to allow for separate view of photos from messages and the ability to reject/accept any combination of those.*

The JPay Team has read, understands and agrees to comply.

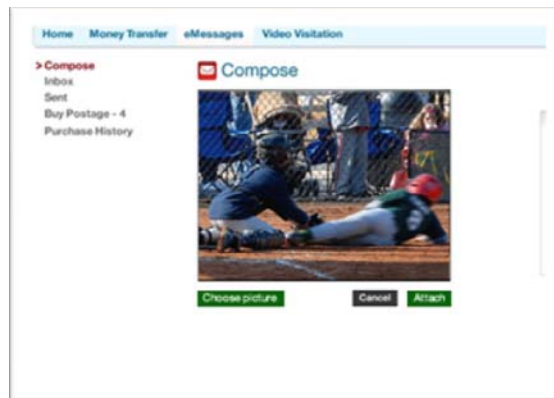
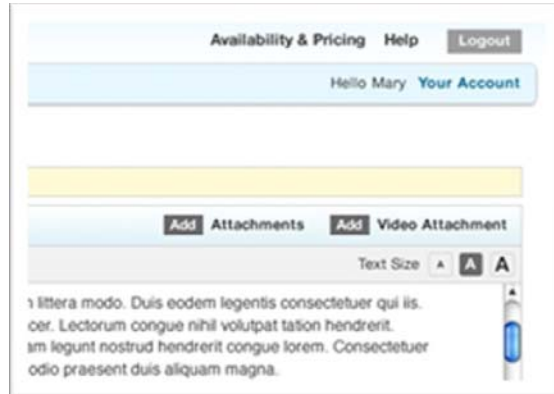

Family and friends can attach digital pictures to their eMessages. Each picture costs one additional stamp. The DOC can limit the number of picture attachments that can be sent with an eMessage.

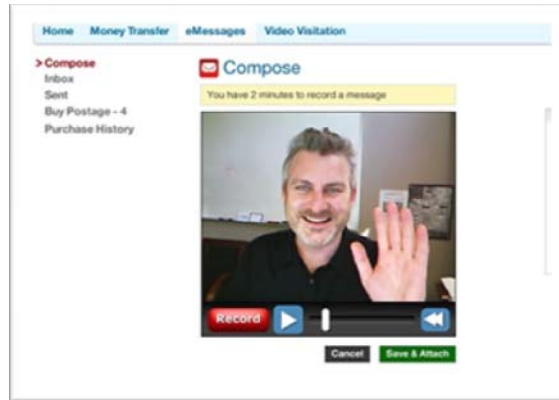

A recent addition to the eMessaging suite is the VideoGram feature. Family and friends can record 30 second VideoGrams and send them as an attachment. The inmate can then view the short video message on the kiosk and also view it anytime by saving it in the eMessage inbox.

In addition, photos can be taken of the inmate from the kiosk's web cam and be sent as a photo attachment back to the sender. This is a feature that can be turned on or off by the DOC on a facility, regional or state-wide basis.

#### *3.2.1.1.4 Estimated impact of email/messaging on the DOC network.*

The JPay Team has read, understands and agrees to comply.

If JPay installs its own network, the eMessaging program will have no impact on DOC resources. If JPay uses a DOC network, the system is very lightweight on bandwidth (approximately 32Kbps).

#### *3.2.1.1.5 Provide a plan for data lines should capabilities at the institutions be limited as a result of this implementation.*

The JPay Team has read, understands and agrees to comply.

JPay's network will not interfere with the DOC's capabilities. For states which let JPay use their data lines, JPay commits to installing additional data lines to increase bandwidth where necessary.

*3.2.1.1.6 Internet access/direct e-mail reply is not allowed within the Nevada Department of Corrections. Vendor to detail how this could be managed with their systems.*

The JPay Team has read, understands and agrees to comply.

JPay's system operates on a "opt in" basis. The system was designed so that inmates can only send messages to individuals who have previously sent them an eMessage. All outbound eMessages are screened according to the security measures detailed above.

*3.2.1.1.7 Vendor to propose both viewing and printing options available for the proposed kiosk.*

The JPay Team has read, understands and agrees to comply.

Once a message is approved by the DOC and released to the inmate, the message is immediately available for viewing in the inmate's inbox. By logging into the inmate's account on the kiosk, the inmate can view the message on the kiosk at any time.

For printing, JPay provides printers for facility mailrooms so inmates have the option to request a printout of any eMessage or attachment for a fee. This option exists everywhere JPay has its eMessage system deployed and it is a good feature that keeps inmates engaged in the service.



Printer Specifications include:

- Dell 2335dn laser printer
- Print Speed Up to 35 PPM
- 600 x 600 dpi resolution

*3.2.1.2 Inmate Banking - Many of the DOC's currently have a system to accept electronic funds transfers. If available, vendors shall provide their capability and system to provide Electronic Funds Transfer. The vendor must outline the process for verification via all methods, such as debit card, credit card, or money order.*

The JPay Team has read, understands and agrees to comply.

JPay is the most widely accepted form of deposit in the corrections space. The company provides electronic funds transfers for 21 DOCs including the Nevada Department of Corrections, Virginia Department of Corrections and a host of other agencies. For each of these clients, JPay consistently retains the highest levels of market share, hands down. In fact, the Nevada Department of Corrections decided to discontinue using JPay's competitors as they failed to meet the service levels provided by JPay. Today JPay is the only electronic method for processing NDOC transactions. JPay has several state DOCs using this service to collect all electronic funds transfers and hopes to convert the DOC into a cashless operation.

The service allows customers to make electronic deposits directed to inmate trust accounts, offender restitution accounts and inmate telephone accounts. The service automates a traditionally cumbersome process for any Department of Correction or private prison operator.

JPay spends a tremendous amount of effort in making sure each electronic funds transfer option is user friendly, affordable and convenient. This has always been the key to JPay's success. A deposit can be made from any of the following channels:

- JPay.com Website
- MoneyGram™ Walk-In Retail locations
- iPhone® and Android® Apps
- Full Service Lobby Kiosks
- In-House Call Center
- Automated Lockbox

### JPay.com Website

The screenshot shows the 'Send Money' interface on the JPay.com website. At the top, there are navigation tabs for 'eMessages' and 'Video Visitation'. Below these is a progress indicator showing 'Step 1', 'Step 2', and 'Step 3', with 'Step 1' being the active step. The main heading is 'Send Money'. A yellow banner prompts the user to 'Choose the account to which you are sending money'. Below this, there is a section titled 'Choose Inmate/Offender' with two radio button options: 'Kevin Stone - 864210' and 'Bob Jones - 4443333'. A link for 'Add or edit inmate/offender information' is provided. A green 'Continue' button is at the bottom right. On the far right, there is a vertical sidebar with the letters 'HE' and a list of characters: 'At', 'Lo', 'Oz', 'op', 'Qz', 'Te', 'Nc', 'Lo', 'Oz', 'op'.

The screenshot shows the 'Send Money' interface on the JPay.com website, Step 2. The progress indicator shows 'Step 2' as the active step. The main heading is 'Send Money'. A yellow banner prompts the user to 'Choose your Payment method and enter the amount'. Below this, there is a section titled 'Add Debit/Credit Card'. It includes fields for 'Card Number' (displayed as '\*\*\*\*\*553'), 'Card Type' (set to 'Mastercard'), 'Expiration Date' (with 'Month' and 'Day' dropdowns), and 'Security code' (displayed as '\*\*\*'). Below the card information is a 'Billing Address' section with fields for 'First Name' (Mary), 'Last Name' (Smith), 'Address' (123 Main St, #212), 'City/Town' (Smallville), 'State' (Choose State), and 'Zip/Postal' (55155). On the right side, there is a 'HELP' section with the text 'About Xxxxx', 'Lorem ipsum', 'Option lorem', 'option et.', 'Qui vel enim', 'Te facit diam', 'Nobis minim', 'Lorem ipsum', 'Option lorem', and 'option et.'.

JPay.com, designed specifically to accept inmate deposits, is fast, easy to use and has maintained 99% uptime for over 8 years. The site accepts Visa and MasterCard credit and debit cards and many alternate forms of prepaid and gift cards.



### MoneyGram™ Walk-In Retail Locations



JPay is the only electronic funds transfer provider in the corrections market with an exclusive relationship with MoneyGram Payment Systems™. Today, a significant portion of cash deposits for inmates come from a MoneyGram location. Friends and family can walk into any of MoneyGram's 30,000 retail locations in the United States to make an inmate deposit in real time. This integration allows the agent to verify inmate information on the spot.

### iPhone® and Android® Apps

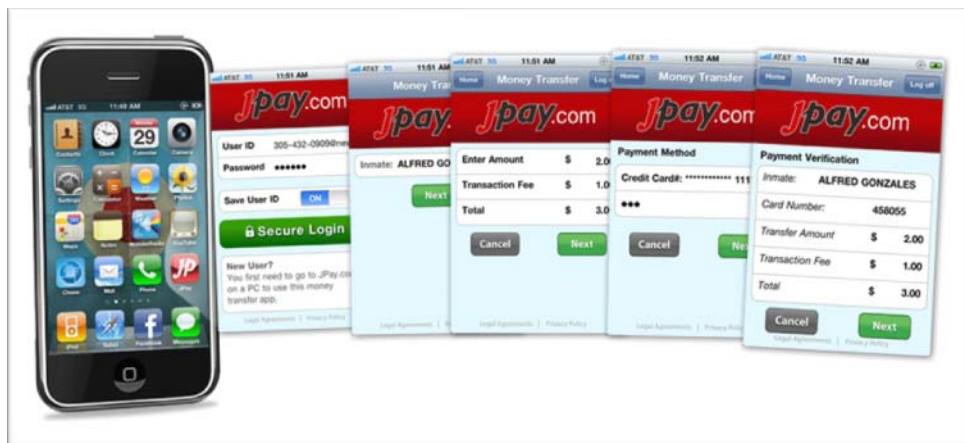

JPay has developed applications allowing customers on the go to make deposits without having to use a personal computer. Deposits are made on either application – the iPhone or the Android app (coming in Spring 2011), with a credit/debit card, and similar to the JPay website, deposit and inmate information is verified in real-time. The iPhone app, newly launched, has proven to be an immediate success and customer adoption rates are soaring. All eyes are on the growth of these new payment avenues.

### Full Service Lobby Kiosks

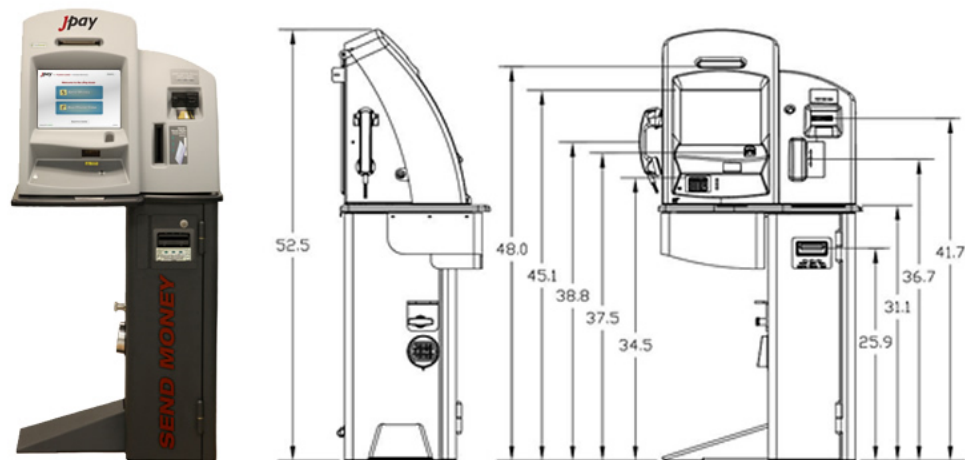

JPay's kiosk solution provides the DOC with the ability to collect cash and credit/debit card deposits in the lobbies of well-trafficked visitation facilities. Kiosks are monitored and maintained to always be available for a customer to make a deposit. The kiosk interface is user-friendly and simple to use.

Maintenance, courier services and customer service is provided at no cost to the DOC. JPay contracts with industry-leading armored courier services (such as Brinks<sup>®</sup>) to collect cash from the kiosk. Pickups are scheduled and determined by kiosk usage. No facility interaction is required for the courier to access the kiosk.

### In-House Call Center

By calling toll-free, customers can make credit and debit card payments from a bilingual live agent or via JPay’s updated Interactive Voice Response (IVR) system. JPay agents are available to accept phone calls as well as emails 24 hours a day, 7 days a week. The call center accepts Visa and MasterCard credit and debit cards and many alternate forms of prepaid cards.

### Automated Lockbox Services

JPay can also offer the DOC a fully outsourced money order processing solution at no cost. JPay can collect and process all money orders, cashier’s checks, and governmental checks for inmate deposits. A unique advantage of using JPay’s lockbox is that all money order data is available on JPay’s system along with all other electronic deposits – giving the DOC a complete picture of all deposits. All lockbox deposits are processed in accordance with each DOC’s policies and procedures.

### Online Facility Management

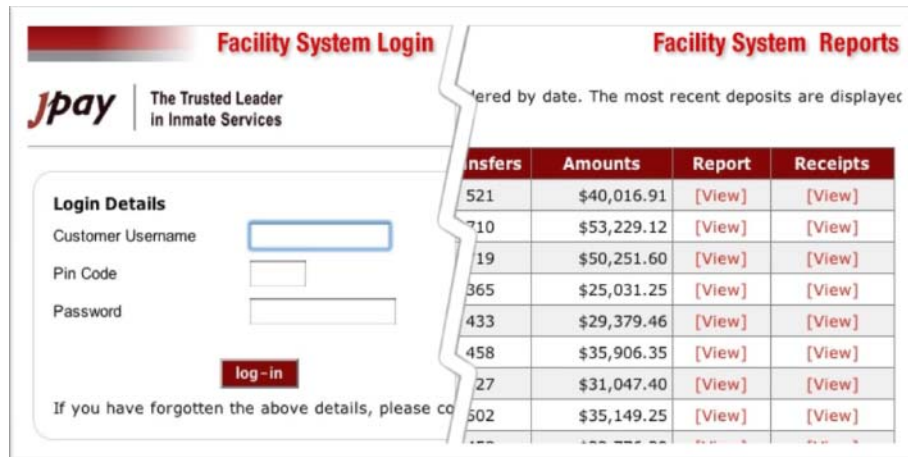

Central office banking staff and facility accountants use the online Facility System to look up deposits, reconcile deposit batches to funds received, help inmate friends and family with transactions and generate reports. Users can easily discover if the transaction was a cash or credit card transaction.

Users can view all deposits on the Facility System by batch, facility, date, inmate and/or customer. Staff can view detailed transaction data including information on the customer, inmate, transaction and much more.

Inmate Information									
Inmate ID:	15393								
Name:	LAWONDA SPURLOCK								
Location:	RTC								
Facility:	Indiana State Prison System								
<a href="#">Export To File</a>									
Deposits									
Page 1 of 1									
Date	Location	TransID	CustomerID	Customer	Amount	Type	Batch	IP Address	
12/02/2010	RTC	11116512	3187916	AMANDA SPURLOCK	\$200.00	MONEYGRAM	01099		
11/03/2010	RTC	10761515	3083041	AMANDA SPURLOCK	\$100.00	MONEYGRAM	01070		
10/15/2010	RTC	10527538	3014103	DANIEL PROFFITT	\$100.00	MONEYGRAM	01051		
09/08/2010	RTC	10088997	2880621	HENRIETTA SPURLOCK	\$50.00	MONEYGRAM	01014		
09/04/2010	RTC	10040273	2865792	DANIEL PROFFITT	\$100.00	MONEYGRAM	01010		
Letters Received									
Page 1 of 2 <a href="#">Show older letters</a>									
Date	Letter ID	Location	CustomerID	Customer	View	IP Address	Deleted By Inmate	Pre-paid Stamp	Inte Pri
12/09/2010	14783697	RTC	3080277	Amanda Spurlock	View	216.8.238.25		Yes	C

The user can also look up customer and inmate transaction history, and even tie it into their eMessaging history. This allows the user to look up an inmate or inmate’s transactional history and find it in one place. Hours of research are saved with this interface.

Recap Report				
Please choose a month to view its report.				
	Transfers	Amount	Transferred	F C
3/2011	1817	\$135,864.04	\$135,864.04	
2/2011	15069	\$1,095,692.07	\$1,095,692.07	
1/2011	13805	\$864,159.17	\$864,159.17	
12/2010	14625	\$934,314.56	\$934,314.56	
11/2010	13453	\$844,103.76	\$844,103.76	
10/2010	14232	\$878,822.90	\$878,822.90	
9/2010	13360	\$813,307.22	\$813,307.22	
8/2010	13113	\$801,810.00	\$801,810.00	

Staff can generate reports from the Facility System and choose to print them or export them to Microsoft Excel or Word. Reports include:

- Monthly batch report (all transactions processed for the month)

- Monthly reconciliation report (details all ACH activity)
- Customer and inmate activity reports

*NOTE: Vendors that accept credit cards must specify that they meet all card requirements for the processing of transactions. Nonpayment of credit card transactions will not be the responsibility of the DOC.*

The JPay Team has read, understands and agrees to comply.

JPay is fully compliant with all federal and state money transmitter statutes, anti-money laundering regulations, Office of Foreign Assets Control (OFAC) and Payment Card Industry (PCI) Data Security Standards. JPay is one of the few companies in the United States able to remit electronic payments to correction agencies under the auspices of money transmitter regulations. Compliance with these regulations is not only required in the industry but essential to meeting agency and customer expectations.

JPay guarantees all payments and is responsible for any credit card disputes, charge backs, reversals or Non-Sufficient Fund items. In addition, JPay takes several proactive steps to ensure payment validity prior to accepting payments. The DOC will never be held responsible for fraudulent or mistaken charges.

*3.2.1.2.1 Exchange data with the DOC Inmate Banking System: including but not limited to bank balances and transaction information. Vendor to describe any limitations to the information can be presented to the inmate through the Kiosk.*

The JPay Team has read, understands and agrees to comply.

Inmate and deposit information can be exchanged daily with any of the participating DOCs in this solicitation. JPay interfaces with numerous agencies and their trust account or offender management systems, including Cashless Systems, the Nevada DOC’s current vendor. The interface is extremely simple and requires minimal resources to accomplish, especially with JPay’s guidance.

Each day, JPay will receive an inmate data file from the DOC via File Transfer Protocol (SFTP or FTP) consisting of all relevant data for inmate identification such as the inmate’s name, ID number, housing location and account balance. Towards the close of each day, JPay sends the DOC a batch file detailing the day’s deposits. The deposits are automatically loaded to the individual inmate accounts.

All funds corresponding to the day’s batch are remitted to the DOC’s bank via an ACH credit every banking day according to the following schedule:

**B** = Deposits received and Batch uploaded to trust accounting system  
**R** = Funds Received in DOC’s bank account

Fri	Sat	Sun	Mon	Tue	Wed	Thu	Fri	Sat	Sun	Mon
B				R						
	B			R						
		B		R						
			B		R					
				B		R				
					B		R			
						B				R

*3.2.1.2.2 Kiosks installed in the visitation area shall be limited to deposits only and to include cash, checks, and credit cards.*

The JPay Team has read, understands and agrees to comply.

JPay’s can provide the DOC with a kiosk to collect cash and credit/debit card deposits in a facility’s visitation area. In order to ensure payment validity, lobby kiosks do not accept checks.

*3.2.1.2.3 Enforce ability to maintain minimum and maximum deposit levels. Machine to have the ability to print deposit receipts.*

The JPay Team has read, understands and agrees to comply.

JPay has the ability to maintain minimum and maximum deposit amounts for each payment method. JPay already has established minimum and maximum deposit limits for each payment method but welcomes the opportunity to work with a DOC in establishing different limits. In most states for example, JPay sets the website and call center maximum payment amount to \$300.00 although the Nevada DOC allows \$500.00 for its Holiday and Gift Program.

The kiosk machine can print a receipt after each transaction.

*3.2.1.2.4 Describe security features that insure accurate deposits, i.e., wrong account numbers.*

The JPay Team has read, understands and agrees to comply.

JPay has a sophisticated system of screening, including suspicious IP address detection and credit card transactional behavior monitoring. For credit/debit card transactions, the customer's information must match the information the issuing bank has on file or the transaction will not be approved.

*3.2.1.2.5 Security - Provide the method of insuring inmate ID security. Vendors to provide their ability to provide bio-metrics, magnetic card readers, or other forms of security.*

The JPay Team has read, understands and agrees to comply.

All deposits made through the JPay system, whether through the kiosk, website or otherwise, will only be successful if the inmate is verified on the inmate file.

All deposit kiosks come equipped with a swipe card reader. To make a deposit, the customer must swipe their ID or credit/debit card. This allows JPay to verify the customer at the kiosk.

*3.2.1.3 Inmate Grievances*

*Vendor to provide internal document routing between inmate kiosk and DOC staff. If this currently does not exist, is there potential for future expansion in this area?*

The JPay Team has read, understands and agrees to comply.

JPay has developed a basic framework for an electronic grievance system that is ready to be customized to meet a DOC's needs. In fact, the company is actively seeking a DOC (or group of DOCs) who will partner with the JPay to develop a robust end-to-end grievance system.



The system lets inmates submit electronic grievances on the kiosk. Grievances are processed and tracked by DOC staff using the Facility System. Users can respond to grievances electronically for inmate viewing on the kiosk. All grievances can be looked up on the Facility System by inmate, date or type of grievance.

#### *3.2.1.4 Ability to Translate Information*

- *Spanish/English-English/Spanish;*
- *Translate Applications/Information from English to other languages.*

The JPay Team has read, understands and agrees to comply.

All screens on JPay's inmate kiosks are available in English and Spanish. All eMessages reviewed on the Facility System can be translated from Spanish (and a myriad of other languages) to English with the click of a button.

In addition, all ads and information campaigns are produced in English and Spanish. JPay's call center has many bilingual agents who are always available to service the Spanish market segment.

#### *3.2.1.5 Inmates Commissary*

##### *3.2.1.5.1 Ordering commissary items directly through the kiosk.*

The JPay Team has read, understands and agrees to comply.

JPay's commissary ordering system, another application that resides on the inmate kiosk, allows inmates to browse and order commissary items using a shopping cart mechanism. Once an interface is developed with the commissary provider JPay can receive real-time inventory, pricing, pictures, fulfillment and shipment information as well as ordering deadlines. Up-to-date information on commissary items will be viewable on the kiosk including the item ID, code, category, price, description and picture.

To order, the inmate places the order using a shopping cart application. All information on an item received from the DOC's existing commissary system will be displayed to the inmate. This serves as an excellent reintegration tool as it teaches the inmate how to browse and complete

purchases. Once the order is submitted, it is queued with all pending orders on the JPay server. The inmate can update or modify the order at any time up until the cutoff time for submitting orders. Once the orders are submitted, they are batch processed and sent to fulfillment.

Behind the scenes, a file with all orders is sent to the commissary vendor for fulfillment. The file contains inmate information (name, ID and, facility, bed assignment, housing location), the date of the order, the order number and the items in the order. Once the order is filled, notifications can be sent to the inmates.

DOC users can manage and control inventory from the Facility System. The system automatically updates the database when items are out of stock or replenished, or if there is a price change or recall. In addition, the system allows DOC staff to limit items based on facility or agency restrictions. For example, if an inmate is diabetic he/she would be unable to order a candy bar without approval.

#### *3.2.1.5.2 Provide holiday or package program orders for the inmates.*

The JPay Team has read, understands and agrees to comply.

JPay has already developed a customized Holiday and Gift Program payment system for the Nevada DOC. Holiday and gift payments are handled differently due to the Nevada DOC's policy of waiving restitution fees against these payments. These payments are also offered seasonally and can be subject to higher transaction maximums.

JPay can also provide holiday or package program orders directly from inmate family and friends or on the kiosk for inmate ordering.

#### *3.2.1.5.3 Interface purchases with the inmate banking system.*

The JPay Team has read, understands and agrees to comply.

JPay develops an interface with the inmate banking system in order to retrieve inmate account balances and debit the accounts for purchases. This data exchange can be performed in real time or via FTP.

### 3.2.1.6 Video Visitation

The JPay Team has read, understands and agrees to comply.

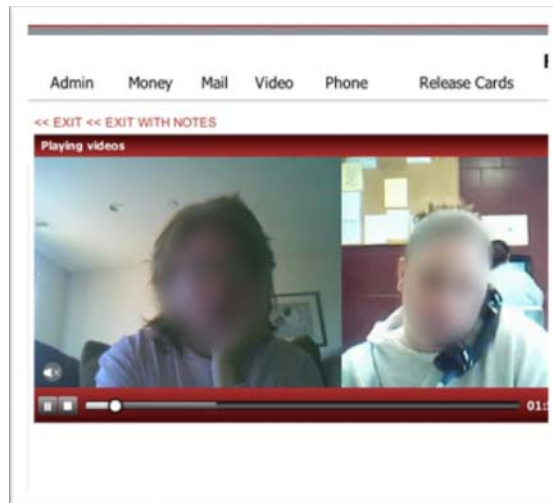

All inmate kiosks come equipped with a camera and phone handset to facilitate JPay's proprietary Internet video visitation application. This service ensures the widest possible access between inmates and friends and family and reduces foot traffic at the facilities. The program has proven to reduce physical visits, decrease the influx of contraband and reduce inmate movement within a facility. To participate, visitors, from home, access the JPay website from a personal computer equipped with a web camera/microphone or visitation. No additional software is required.

The JPay website gives customers the ability to test their connectivity to the video visitation system before engaging in a video visit with an inmate. This feature is free and has proven essential in ensuring the parties will enjoy their video visit without any connectivity issues.

Here is how it works:

1. Customer uses [www.JPay.com](http://www.JPay.com) to schedule and pay for a session.
2. Inmate's availability is checked against location and custody level.
3. The system verifies availability of kiosks within a unit.
4. Inmates are notified via an eMessage when a session is scheduled.

5. The system connects both parties at the scheduled time for the session.

All sessions are recorded and available to DOC staff on the Facility System. In addition, DOC staff can monitor all sessions in real time. Staff has the ability to disable any visit for any reason.

*3.2.1.6.1 Requirements for data transfer for video visitation.*

- The JPay Team has read, understands and agrees to comply.

Video visitation uses Flash Media Server technology and does not require a PBX, audio equipment, or any hardware at the DOC other than JPay's inmate kiosk.

*3.2.1.6.2 Estimated impact of video visitation on the DOC network.*

- The JPay Team has read, understands and agrees to comply.

The anticipated bandwidth consumption per inmate kiosk is 128Kbps.

*3.2.1.6.3 A plan for data lines should capabilities at the institutions be limited as a result of this implementation.*

- The JPay Team has read, understands and agrees to comply.

JPay's network will not interfere with the DOC's capabilities. For states which let JPay use their data lines, JPay will be responsible for installing additional data lines to increase bandwidth wherever permitted.

*3.2.1.6.4 Vendor to propose recommended visitation time constraints.*

- The JPay Team has read, understands and agrees to comply.

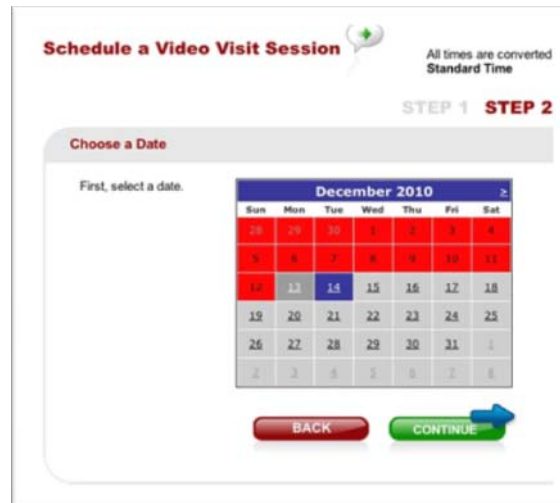

Facility System users have the ability to set time constraints and limit the length of each session. As DOCs restrict visits from being scheduled during meals or mandatory cell count times, customers will only be allowed to request a video visit when the inmate is available.

*3.2.1.7 Inmate Scheduling*

*Vendor to provide any scheduling capabilities i.e. inmate medical appointment scheduling.*

- The JPay Team has read, understands and agrees to comply.

In addition to customizing a solution for inmate grievances, JPay also desires to custom build a scheduling application that allows inmates to schedule medical or any other appointments that the DOC desires. Since kiosk calendars are managed on JPay's system, it's a logical next step to have a scheduling and calendar application for inmates.

### 3.2.1.8 MP3 – Download / Purchasing of Music

The JPay Team has read, understands and agrees to comply.

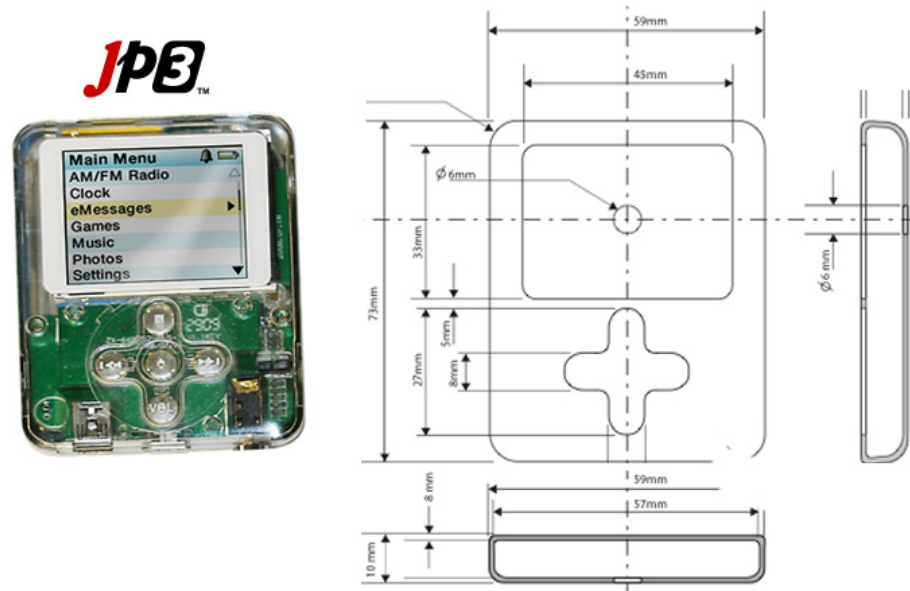

The inmate kiosk has a custom music store application that lets inmates preview, purchase and download music and media onto a corrections grade MP3 player - the JP3™ player.

This application has been recently introduced to the market and is currently deployed in facilities in the Washington, Georgia and Pennsylvania Department of Corrections. The new service has been a resounding success. The model of putting multiple kiosks in each facility has proven to sell far more songs per inmate and has more adoption per facility making it the absolute best choice for any agency.

*Vendor must be able to customize music catalog for approval by institutions by State.*

- The JPay Team has read, understands and agrees to comply.

Each DOC is able to modify the availability of different genres/songs from the music catalog (i.e. not allow music with explicit lyrics or parental advisories). This feature is available to DOC users on the Facility System.

*3.2.1.8.1 Ability to download with and without direct access to the internet;*

- The JPay Team has read, understands and agrees to comply.

JPay provides inmates the ability to browse the music store, preview songs and purchase music on the kiosk. Once the purchases are approved, the songs are downloaded asynchronously and placed on a local download manager (“LDM”). When the inmate logs into the kiosk, the kiosk checks for songs already downloaded by the LDM and copies the songs onto the JP3 player. Inmates do not have access to the Internet or to the LDM.

*3.2.1.8.2 Secure MP3 music downloads solutions;*

- The JPay Team has read, understands and agrees to comply.

The LDM is the only machine allowed to download songs for the inmates. The inmate kiosks connect to the LDM and grab songs intermittently so the inmate kiosks do not have to connect to the JPay server continuously to download songs. This limits bandwidth activity and provides a secure solution for the DOC as firewall rules restrict the LDM and inmate kiosks to only connect to JPay sanctioned IP addresses.

*3.2.1.8.3 Offer a large variety of titles and genres available for purchase;*

The JPay Team has read, understands and agrees to comply.

The kiosk's Media Store features 10.5 million titles from every major record label, and allows inmates to search music by genre, popularity, artist and new releases. One popular feature is a feed of the DOC's top sellers which will always display the top purchased songs at each DOC.

The advantage of having a live catalog is that available music is updated daily from the record label. JPay's advantage is that those changes are driven to the kiosks in real time.

*3.2.1.8.4 Alternative methods that allow the inmates to search and choose music (to place in a queue) without being connected to the kiosk. This includes the ability to choose order of preference and deleting selections in the queue;*

The JPay Team has read, understands and agrees to comply.

JPay provides access to the music catalog for all inmates, regardless of whether they are indigent or have a healthy-sized trust account balance. All the inmate has to do is log into a kiosk in their housing unit and begin learning about the program. This is also the first and most critical step to attaining inmate adoption. Other vendors only allow those who have purchased handheld devices the privilege of browsing the music catalog. As all inmates are afforded the opportunity to browse and preview music, it's no wonder there is such a high demand for JPay's digital media solution.



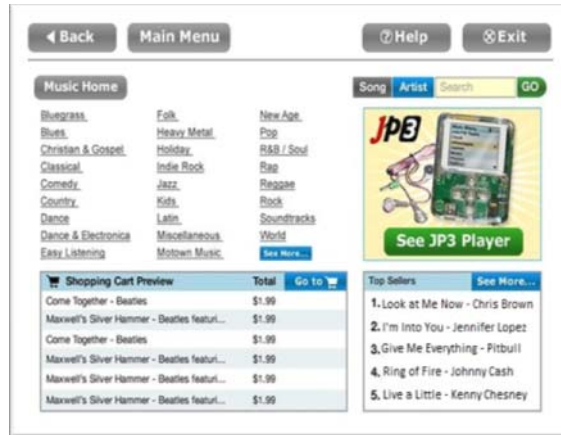

Providing the ability to search for music on the kiosk ensures that the catalog will always be up-to-date at the point of sale. This eliminates complaints from inmates who purchase unavailable content, which is a problem with static catalogs that are available on other handheld devices.

The music catalog displayed on the kiosk is updated constantly so that any new additions or changes are reflected immediately. When new music becomes available, inmates do not have to wait and synch with the kiosk to get the latest catalog, as is the process with systems which only offer catalog visibility through the player. Such systems often display and may even deduct inmate funds for the purchase of media items which are no longer available. With JPay's program, inmates can browse, preview and buy new music (songs, albums and compilations) immediately.

*3.2.1.8.5 Download/data retrieval times;*

The JPay Team has read, understands and agrees to comply.

The average download time depends on the network speed and the size of the song. If JPay installs its own wireless network, a typical song of 10 megabytes takes about 5 seconds to be transferred to the JP3 player.

*3.2.1.8.6 Security features and if features can be disabled upon release for normal use. This includes any locking features to prevent music sharing, etc. Vendor to describe theft prevention features;*

The JPay Team has read, understands and agrees to comply.

JPay's digital media platform is built solely for correctional environments with a security first approach. Not only are the player and media applications secured with the most up to date industry protection but the player is locked from nuts to bolts.

V3.5 - 2/24/2011

Property of  
Angela Harrah  
54321  
331

The JP3™ player displays the inmate's name and ID number when the device is turned on. JPay uses FTP to send the DOC the inmate ID associated with each purchased player, which can be stored in a back end inventory system. This provides for easy detection of player theft since both JPay and facility staff have access to device monitoring.



The device is programmed to only connect to the kiosk software and only to the account that matches the owner of the JP3™ player. If an unauthorized attempt is made, an error message is displayed and the connection will fail.

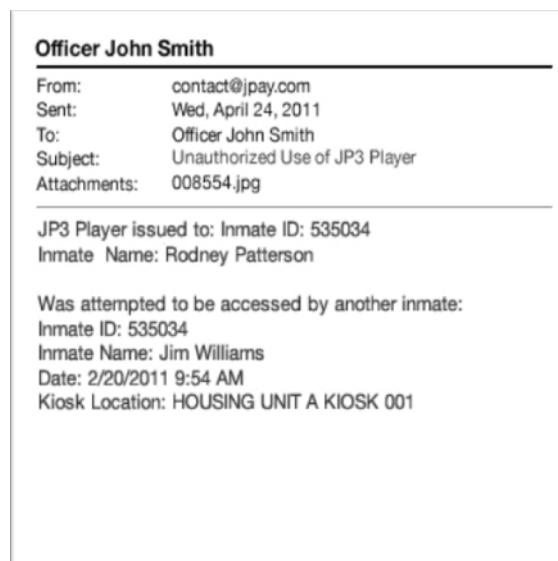

When unauthorized use is attempted, such as an inmate trying to log into another inmate's kiosk account, a notification alert is also sent via email to appropriate DOC personnel.

The inherent risks associated with player theft and subsequent purchase abuses are greatly minimized when inmates are required to go through a secure login process in order to access the music catalog. Only after an inmate logs into their kiosk account with a username and password can they browse and purchase music.

Released inmates will be able to ship their player back to JPay to get it unlocked. The process is free and the takes no more than five business days.

*3.2.1.8.7 Capabilities of the actual MP3 player to be used. Are there base/upgraded versions? What is the min/max gigabyte capacity?*

The JPay Team has read, understands and agrees to comply.

The JP3 comes standard with a 4 GB base of memory. Additional memory can be purchased as well. Upgraded versions offer 8 as well as 16 GB.

*3.2.1.8.8 Describe power features and how recharging of the player is achieved;*

The JPay Team has read, understands and agrees to comply.

The JP3 player includes a lithium-ion rechargeable battery and an AC adapter. An alkaline battery model of the JP3 player and rechargeable alkaline batteries are also available should the DOC desire.

*3.2.1.8.9 Must be able to provide inmate with transaction data/account balance;*

The JPay Team has read, understands and agrees to comply.

Inmates will be able to access transaction data and account balances on the kiosk prior to purchasing music. Bundled with the kiosk application is an inmate banking application that allows inmates to check their account balances and even see previous transactions or bank statements, depending on the capabilities of the DOC's inmate banking system.

*3.2.1.8.10 System to be able to catalog inmate songs in a database; the ability for the inmate to manage his total music library;*

The JPay Team has read, understands and agrees to comply.

JPay recently introduced new functionality to the inmate kiosk application that allows the inmate to manage his/her music library. This new feature is called "My Player" and allows the inmate to manage his/her player library from an easy to use interface.

*3.2.1.8.11 Player must be clear to provide viewing of internal components;*

The JPay Team has read, understands and agrees to comply.

The JP3 has clear casing for the player as well as all components:

- Ear Bud Headphones (clear)
- Battery Charger (clear)
- USB Cord (11" length)
- Batteries

*3.2.1.8.12 DOC must have the capability to approve all music available to purchase on the catalog; and*

The JPay Team has read, understands and agrees to comply.

From the Facility System, the DOC can restrict albums or songs from being available in the catalog. For example, all albums with a parental advisory warning can be withheld from the media store.

*3.2.1.8.13 Vendor must have contractual rights to distribute digital media from major music labels or other entertainment fields to provide reasonable volume of acceptable media content.*

The JPay Team has read, understands and agrees to comply.

JPay has the rights to over 10.5 million songs from all four major record labels and a vast Indie catalog. JPay underwent a rigorous process to have the labels grant JPay authorization to access and redistribute copyrighted materials.

*3.2.1.9 Phone Time Usage*

*Capabilities for the kiosk to provide tracking of phone time usage.*

The JPay Team has read, understands and agrees to comply.

JPay can integrate with the DOC's phone vendor to allow inmates to track usage, manage calling lists and transfer funds between commissary and

phone accounts. JPay currently has this interface in place in several jurisdictions.

#### *3.2.1.10 Application Architecture*

##### *3.2.1.10.1 Open source application.*

The JPay Team has read, understands and agrees to comply.

All of JPay's applications are proprietary.

##### *3.2.1.10.2 Documented Interface API and tool kit ad.*

The JPay Team has read, understands and agrees to comply.

JPay has a documented interface API which is available for use by the DOC. We do not have a tool kit. However JPay developers are free to assist DOC developers if necessary.

##### *3.2.1.10.3 Custom changes to the Interface API.*

The JPay Team has read, understands and agrees to comply.

JPay has the ability and will be happy to provide custom changes for the DOC.

#### *3.2.1.11 Interfacing*

##### *3.2.1.11.1 Vendor to detail their capability to interface vendor's applications to DOC applications.*

The JPay Team has read, understands and agrees to comply.

JPay has extensive experience interfacing with both off-the-shelf and custom-designed DOC (and outside vendor) applications. JPay has interfaced with over 50 systems, large and small, and is more than capable of interfacing with the DOC.

#### *3.2.1.11.2 Security and capability when interfacing to DOC applications.*

The JPay Team has read, understands and agrees to comply.

All communications take place over Secure Socket Layer (SSL). However if a DOC chooses to communicate in real time, as does the New York City Department of Correction, then JPay can easily accommodate the requirement.

#### *3.2.1.12 Communications*

*Kiosks to support communications via:*

- *Cable*
- *Wireless*
- *DSL*
- *Other*

The JPay Team has read, understands and agrees to comply.

JPay's inmate kiosks will work with any or all of the listed communications methods. JPay's preferred method is wireless, though we are also able to provide cable or DSL if required by an individual DOC.

#### *3.2.1.13 Scalability*

*Vendor to recommend number of inmate to kiosk ratio and how their system can adjust based on changing inmate populations. Provide all assumptions used to identify required computing power and/or hardware.*

The JPay Team has read, understands and agrees to comply.

JPay recommends that kiosks be installed at a rate of 1 per 150 inmates within each facility's housing units. This inmate to kiosk ratio prevents cross-pollination and the need for additional security personnel to escort inmates through restricted areas in order to access a kiosk. Each kiosk hosts all of JPay's applications which eliminates the need to have multiple devices performing different tasks.

Usually, high traffic kiosks are identified immediately and low traffic kiosks

are moved to high traffic locations. Inmates do not wait in lines to access a kiosk and can do so one at a time, in a comfortable manner.

Immediately following contract award, JPay's deployment team will tour each facility to determine optimal placement for the inmate kiosks. Considerations include access to proper connectivity and power as well as security and ease of inmate movement.

### *3.2.2 Software Requirements*

*The successful vendor shall provide a kiosk application that will run on an operating system designated by the DOC and is capable of being upgraded.*

*The successful vendor shall allow for additional applications to be added as determined necessary by the DOC. Upon mutual agreement between the vendor and the DOC, additional applications can be added via change order to the kiosk while this contract or its extensions are in effect, at the department's option.*

*Vendor must provide any and all upgrades that become available during the term of the contract.*

The JPay Team has read, understands and agrees to comply.

All JPay applications and software are designed for the Microsoft® Windows operating system. JPay is happy to accommodate requests for additional applications and feature modifications, as evidenced by the development of the Holiday and Gift Program for the Nevada DOC.

JPay periodically upgrades its software and systems. All updates are loaded onto field equipment remotely.

*3.2.2.1 Third Party Acquisition of Software: vendor shall notify the Department in writing if its intellectual property, business, or all of its assets are acquired by a third party.*

The JPay Team has read, understands and agrees to comply.



*3.2.2.2 Title of Software: Vendors submitting a proposal represents and warrants that it is the sole owner of the software or, if not, the owner, has received all legally required authorizations from the owner. Vendor to provide the following documentation:*

- *Term of software license.*
- *Rights to Computer Software.*

The JPay Team has read, understands and agrees to comply.

JPay warrants that it is the sole owner of the software. As all of JPay's software is proprietary and built in-house, no license or additional documentation is needed.

*3.2.2.3 Touch screen monitor shall reduce the ability to read the screen when viewed from the side to prevent others from viewing displayed information. Touch screen shall not require scrolling.*

The JPay Team has read, understands and agrees to comply.

JPay installs privacy screens on all inmate kiosk monitors to prevent side viewing. These privacy screens are extremely effective at preventing inmates from viewing a kiosk user's account information. Kiosks with privacy screens have been in the field for over 2 years.

### *3.2.3 System Architecture*

*3.2.3.1 The capability for the development of future applications and implementing these applications on the proposed hardware configuration.*

The JPay Team has read, understands and agrees to comply.

JPay designs and builds all of its applications from scratch. The applications are all built to run effortlessly on the kiosk architecture. JPay has not mixed and matched partners and acquisitions to offer a mixed bowl of technology. Rather, JPay's solutions are all compatible and maintained by one team, the JPay development team located at the company's headquarters in Miami Florida.

Not only will the applications continue to develop in number and in functionality, but the hardware will change with time as well. To be specific, JPay is currently developing a handheld device designed to augment our digital

media solution.



JPay's next generation device, the JP5™ tablet, gives inmates the ability to view, draft and send eMessages from the convenience of their cells. Inmates simply synch up whenever they need to send and receive messages. The synch can happen from the kiosks or wirelessly. The JP5 also provides access to interactive educational content as well as television and movies.

This tablet will serve as an excellent reintegration tool as inmates learn how to complete job applications and navigate common computer programs.

*3.2.3.2 Vendor shall ensure that the system architecture is scalable and designed to easily and inexpensively accommodate changes (future applications, etc) resulting from DOC rules and workflows.*

The JPay Team has read, understands and agrees to comply.

All of JPay's systems are completely scalable with the ability to increase server number and size to meet consumer demand. There is no limitation on data storage of any of JPay's service data. In fact, we anticipate a growing increase in usage and have designed our server capacity to grow in parallel.

Through the years, JPay has continuously modified our system to accommodate

DOC requests. At the Texas Department of Criminal Justice for example, the Office of the Investigator General requested that JPay design an alert system that allows the trust accountants, mailroom staff, and investigators to forward sensitive inmate trust account deposit and eMessaging data from one staff member to another via JPay's system. JPay not only developed this feature, but trained staff at all 107 State facilities to make sure that the tool was prepared for maximum usage.

*3.2.3.3 Vendor must allow for the kiosks to be data linked within an institution, and best case to be linked throughout the Department.*

The JPay Team has read, understands and agrees to comply.

*3.2.3.4 Provide the capability of producing reports, including but not limited to:*

- *Use and statistical reports by function. (i.e., Banking queries, store sales, phone time, etc; and*
- *Accounting reports.*

The JPay Team has read, understands and agrees to comply.

Staff can generate all types of reports from the Facility System and choose to print them or export them to Microsoft<sup>®</sup> Excel or Word for sorting and format customization.

Reports for each service include:

- User Reports
- Facility Reports
- Agency-wide reports
- Usage analytics
- Transaction history reports
- Revenue and other recap reports

*3.2.3.5 Provide a kiosk application that will run on a operating system designated by the DOC and is capable of being upgraded.*

The JPay Team has read, understands and agrees to comply.

JPay's kiosk application runs on the Microsoft<sup>®</sup> Windows operating system and

is capable of being upgraded.

*3.2.3.6 Touch screen buttons and font sizes large enough to be easily read by the majority of customers.*

The JPay Team has read, understands and agrees to comply.

Kiosk screen font sizes are large enough to be read by the majority of inmates. Touch screen is available but not standard as each kiosk is equipped with a keyboard and trackball mouse.

*3.2.3.7 Provide kiosk application instructions to the inmates which are clear and to the point, with no large blocks of text.*

The JPay Team has read, understands and agrees to comply.

All kiosks have detailed instructions and an FAQ for each application. If inmates have questions or concerns about an application, they can submit a support ticket directly from the kiosk which will be answered by a JPay customer support team member.

*3.2.3.8 Vendor shall ensure each kiosk is maintained on the most current version of the vendor's systems of operation, with no more than two versions at any one-time across all kiosks.*

The JPay Team has read, understands and agrees to comply.

*3.2.3.9 Kiosk Operational Statistics to include:*

*At minimum, internal operational software.*

*Ability to look at up-time logging data and monitor kiosks.*

*Full monitoring capabilities; KVM/Power.*

The JPay Team has read, understands and agrees to comply.

Internal operational software is proprietary. Performance is monitored at all times by a software monitoring application which sends system alerts to JPay technicians. JPay utilizes a VPN to control the internal computer remotely allowing the kiosk to be maintained, rebooted and upgraded as needed. All

events are recorded and easily audited.

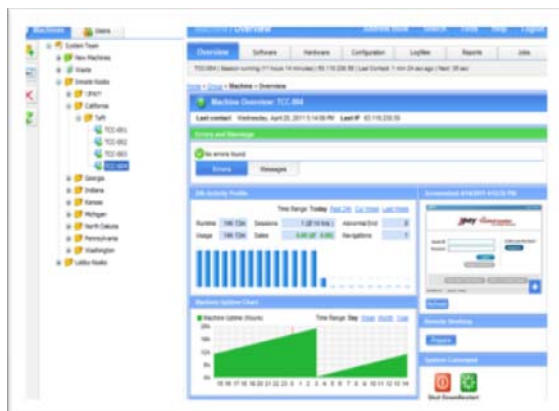

*3.2.3.10 Data transfer in your operating system. Please include specification for eXtensible Markup Language (XML) or other standard interface options, to tie in a kiosk-based application with offender management systems.*

The JPay Team has read, understands and agrees to comply.

JPay's inmate kiosks use web services to communicate with back office. Those web services can be used to tie in a kiosk-based application with offender management systems.

### *3.2.4 Customer Interaction Messages*

*Messages to be available in English and Spanish.*

The JPay Team has read, understands and agrees to comply.

*Vendors are to describe in detail the following:*

#### *3.2.4.1 Transaction processing messages;*

The JPay Team has read, understands and agrees to comply.

When a customer submits a transaction on JPay.com, an easy-to-understand message informs them of transaction status:

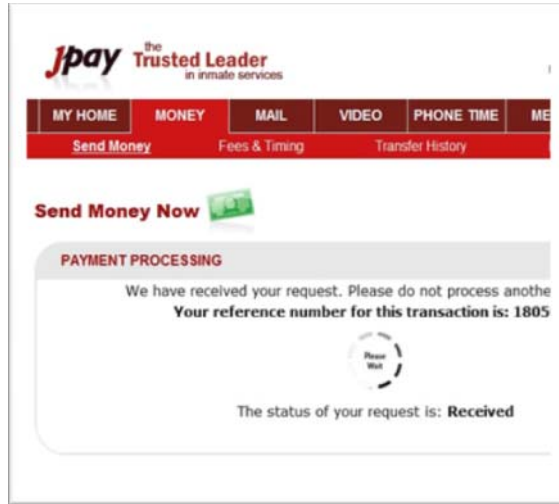

*3.2.4.2 What messages prompt the inmate during their time on the kiosk;*

- The JPay Team has read, understands and agrees to comply.

Throughout the kiosk session, a timer on the bottom of the screen indicates how much time remains in the inmate’s kiosk session. An additional message appears when there are five minutes remaining.

Additional prompts include confirmations after selecting or deleting an item for purchase in both the media and commissary modules.

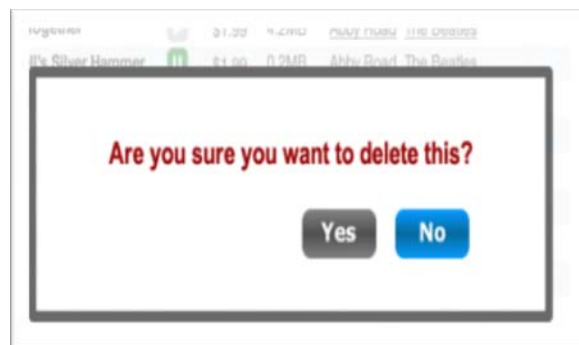

*3.2.4.3 Error message, can the error message be customized?*

The JPay Team has read, understands and agrees to comply.

Any and all error messages, on both the inmate as well as customer-facing interfaces, can be customized to meet each individual DOC's specifications. In fact, most error messages need to be customized in order to meet each administrative directive for each jurisdiction. JPay's system was designed to accommodate this.

*3.2.4.4 Does functionality include instructional prompts?*

The JPay Team has read, understands and agrees to comply.

All of JPay's functionality features user-friendly instructional prompts, available in English and Spanish. In addition, JPay will provide signs and "How-to" guides next to each kiosk.

*3.2.4.5 Transaction processing messages to indicate what messages prompt the inmate during their time on the kiosk. This should include error messages.*

- *Can the error message be customized?*
- *Does the functionality include instructional prompts?*

The JPay Team has read, understands and agrees to comply.

All transaction processing as well as error messages can be customized. All prompts can be customized as well, and include easy to understand instructions.

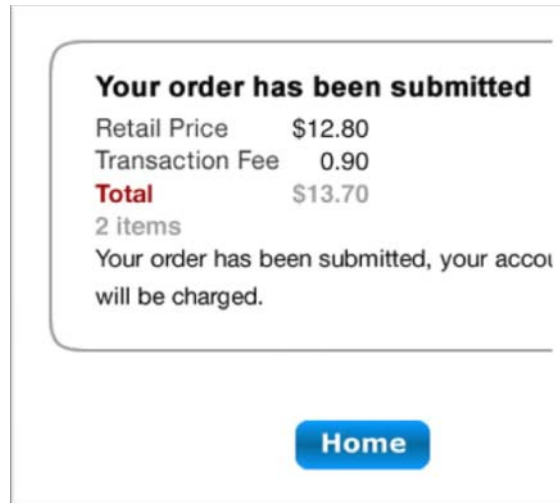

### 3.2.5 Remote Management

*At minimum, remote Keyboard/Video/Mouse (KVM) reset is required.*

The JPay Team has read, understands and agrees to comply.

JPay monitors all installed equipment from our NOC and can reset these devices remotely. Any loss of critical, significant, or less than significant functionality will prompt a reboot, which generally resolves the majority of functionality issues.

*3.2.5.1 Vendor to detail remote management capabilities. To include the following:*

- *Monitoring;*
- *Diagnostics;*
- *Error resolution;*
- *Software problem assistance;*
- *Intelligence reporting;*
- *Application and software updates and upgrades; and*
- *Rebooting and controlling the remote kiosks from a central location.*

The JPay Team has read, understands and agrees to comply.

NOC technicians continuously monitor all hardware, software, and system performance. This allows our dedicated personnel to diagnose and resolve issues, often before the DOC notices a problem. If the NOC is unable to remotely resolve a software issue, technicians may be dispatched to conduct onsite repairs. If the team detects that a larger fix is required, JPay collaborates



with the account manager and field technicians to resolve the issue.

All application and software updates are loaded onto field equipment remotely. These upgrades are vetted by a Change Control Committee, then subject to a rigorous testing phase before being released into the field. JPay monitors and manages the entire process remotely, allowing for zero impact on DOC resources.

*3.2.5.2 Remote management should be set through a security access designation.*

The JPay Team has read, understands and agrees to comply.

### *3.2.6 Software Provisions*

*3.2.6.1 Vendor shall provide any and all software upgrades that become available during the term of the contract.*

The JPay Team has read, understands and agrees to comply.

JPay will provide software upgrades once a month and will notify the DOC ahead of time. All upgrades are deployed remotely during off-hours and JPay will provide additional training on new features, if needed.

*3.2.6.2 Third party Acquisition of Software - The vendor shall notify the department in writing if its intellectual property, business, or all of its assets are acquired by a third party.*

The JPay Team has read, understands and agrees to comply.

*3.2.6.3 Title of Software – By submitting a proposal, the vendor represents and warrants that it is the sole owner of the software or, if not, the owner, has received all legally required authorizations from the owner.*

The JPay Team has read, understands and agrees to comply.

JPay represents and warrants that it is the sole owner of the software.

*3.2.6.4 Term of software license.*

The JPay Team has read, understands and agrees to comply.

All of JPay's software is proprietary and built in-house. As such, no license is required.

#### *3.2.6.5 Rights to Computer Software.*

The JPay Team has read, understands and agrees to comply.

As the sole owner and developer of its computer software, JPay retains all rights in its software.

#### *3.2.7 Hardware Requirements*

*Vendor must describe the capability for the development of future applications and implementing these applications on the proposed hardware configuration.*

The JPay Team has read, understands and agrees to comply.

The JPay R&D team has developed 3 hardware devices to date and plans on launching at least 2 additional devices in the next 18 to 24 months. These mobile devices are able to host all of JPay's kiosk applications and will be able to be used anywhere in the facility.

*Vendors to describe in detail the ability to provide the following:*

*3.2.7.1 Vendor shall provide for all electrical equipment to operate on a regular 120 volt, 60 hertz, AC power and be "UL" or equivalently listed and be certified by a Nationally Recognized Testing Laboratory to be compliant with the FCC regulations.*

The JPay Team has read, understands and agrees to comply.

All electrical components of JPay's inmate kiosk are "UL" certified and operate on 120 volt, 60 hertz, AC power.

*3.2.7.2 Monitors must be Energy Star Compliant with a minimum level of EPEAT Bronze. Monitors must be a minimum of 17" in size across the diagonal, having an associated graphics control board with video drivers. Monitor must be able to withstand operating temperatures of 110 degrees and 100% humidity.*

The JPay Team has read, understands and agrees to comply.

JPay's turn-key, stand-alone outdoor kiosks include 17", Energy Star Compliant monitors. However, the inmate kiosks can only withstand temperatures between 20 and 105 degrees.

*3.2.7.3 Describe alternatives for offenders with disabilities. i.e., Large print options; Text reader options for the blind; Assistive key-stroke functionality for paralyzed offenders.*

The JPay Team has read, understands and agrees to comply.

JPay's kiosk already has ADA compliant components but will not be in full compliance with this section until fourth quarter 2011.

*3.2.7.4 Vendor to propose solutions that would assist the visually impaired.*

The JPay Team has read, understands and agrees to comply.

JPay's kiosk already has ADA compliant components but will not be in full compliance with this section until fourth quarter 2011.

*3.2.7.5 Each kiosk must have a touch screen video display monitor capable of displaying digitized photographs, graphics, and videos, etc.*

The JPay Team has read, understands and agrees to comply.

JPay's kiosks have monitors that are capable of displaying digitized photographs, graphics and videos. JPay strives to build products that assist inmates with reintegration. As touch screens are not needed on a home or work PC, JPay's kiosks do not come standard with this component. However, if the DOC determines this is a necessity, JPay can easily provide touch screens on inmate kiosks.

*3.2.7.6 Touch screen monitor must be secure, safe and capable of withstanding heavy usage in a correctional environment. It must be scratch resistant. Vendor must provide any special care required to keep the screen clean, and prolong the viewing and usage life expectancy.*

The JPay Team has read, understands and agrees to comply.

*3.2.7.7 Touch screen monitor shall not be of the “overlay” or “membrane” type. If a “surface acoustic” or “capacitive” technology is not utilized, the vendor must provide an explanation of why another technology is being proposed.*

The JPay Team has read, understands and agrees to comply.

*3.2.7.8 Touch screen monitor must reduce the ability to read the screen when viewed from the side to prevent others from viewing displayed information.*

The JPay Team has read, understands and agrees to comply.

JPay installs privacy screens on all inmate kiosk monitors to prevent side viewing.

### **3.3 SECURITY REQUIREMENTS**

*Vendors to describe in detail how the following security requirements will be performed:*

*3.3.1 System must be able to support secure wireless, if required by using facility.*

The JPay Team has read, understands and agrees to comply.

JPay has developed a new standard for prison-grade connectivity - a dedicated and proprietary secure wireless network (“WiFi”). JPay will install a WiFi network at each facility to provide connectivity for the kiosks and digital media solution. To ensure outstanding reliability, this network is fully redundant, so if one wireless access point goes down the remaining points are able to compensate, providing 99.9% uptime with strong connectivity.

JPay is the only vendor to have campus-wide wireless networks deployed in a correctional environment. This architecture allows inmates to access the network from a kiosk in their housing unit or from a handheld device in their cell. The wireless network has broken new ground, and JPay has taken the helm by constructing this environment for 5 state correctional agencies.

Wireless systems offer connectivity virtually anywhere through the facility, connectivity is at least 99% and there are no additional charges per use. Agencies employing a wireless network can utilize multiple kiosks throughout the institution

without intermittent signal strength, communication gaps, or inconsistent uptime.

Inmate kiosks come equipped with WiFi antennas capable of accessing the mesh network. The kiosks would then be placed in strategic locations based on connectivity optimization, while taking into consideration inmate movement, safety and security.

*3.3.2 Kiosks may or may not connect to DOC information technology infrastructure.*

The JPay Team has read, understands and agrees to comply.

The mesh broadband network is completely independent of DOC resources and does not interfere with facility traffic or the exchange of proprietary information.

*3.3.3 Vendor to detail plans to support their proposal both ways.*

The JPay Team has read, understands and agrees to comply.

Inmate kiosks can also connect to a local network provided by the DOC. A bandwidth of 10 Mbps must be available for the kiosks and firewall rules must be in place to insure access to JPay servers. JPay's experienced deployment technicians will partner with DOC's IT staff to ensure all security protocols are met.

*3.3.4 Incoming e-mail is screened by the system using keyword search before download is allowed. Keyword screening would evaluate risk level of e-mail. Unacceptable or questionable (moderate to high risk) e-mail is held or staged at a central location computer for DOC approval before it is available for offender delivery or download.*

- *Keyword search may be edited at any time.*
- *Offender email must be stored by vendor or transferrable to DOC storage.*

The JPay Team has read, understands and agrees to comply.

*3.3.5 Internet access/direct e-mail reply is not allowed within the Nevada Department of Corrections. Vendor to detail how this could be managed with their systems.*

The JPay Team has read, understands and agrees to comply.

*3.3.6 MP3 music downloads – Player connects and accepts downloads only from the secure kiosk. No direct access to the internet within the Nevada Department of Corrections. Vendor to detail plans to support their proposal with and without direct access to the internet.*

The JPay Team has read, understands and agrees to comply.

*3.3.7 Recording Video Visitations*

The JPay Team has read, understands and agrees to comply.

*3.3.8 Vendor must have contractual rights to distribute digital media from major music labels or other entertainment fields to provide reasonable volume of acceptable media content.*

The JPay Team has read, understands and agrees to comply.

### **3.4 MAINTENANCE / SERVICE**

*3.4.1 Software Modification by the vendor and Release Management.*

*3.4.1.1 Department initiated modification to the software; the vendor shall provide the following:*

- *Timely cost estimates; and*
- *Reasonable delivery date for enhancements, as mutually agreed upon.*

The JPay Team has read, understands and agrees to comply.

JPay continuously develops software enhancements based on DOC requests and

recommendations. Most developments are provided at no cost to the agency.

All software changes will be presented to the DOC for approval along with estimated delivery dates. Complete documentation will be provided at the time of the software upgrade.

*3.4.1.2 The vendor will prepare software releases and stages for testing, validation and acceptance in a test environment. The Department will perform testing for authorization to proceed prior to migration to production environment.*

The JPay Team has read, understands and agrees to comply.

All application and software updates are vetted by a Change Control Committee, then subject to a rigorous testing phase before being released onto field equipment remotely.

*3.4.1.3 The vendor shall propose, provide, and describe their solution for change management. These must include at a minimum:*

- *Version number;*
- *Description of the change;*
- *How the change was initiated (i.e. user or system support);*
- *Person requesting the change;*
- *Person responsible for the change; and*
- *Date and time of the change.*

The JPay Team has read, understands and agrees to comply.

Please see attached documentation.

*3.4.1.4 Vendor to provide maintenance and service plan to include frequency and speed of maintenance. Downtime shall not extend past a 24 hour period.*

The JPay Team has read, understands and agrees to comply.

Whenever possible, all software maintenance is conducted remotely. If JPay cannot resolve a software issue within one business day, a local technician will be dispatched. The centralized design of our system and our monitoring of the platform by the NOC 24x7x365 allows us to discover and correct problems before the DOC becomes aware of them. As such, few situations require a

technician to dispatched to a DOC. Problem resolution occurs within minutes and not hours as is typical with premised-based systems.

JPay also operates a comprehensive Help Desk which lets customers, inmates and DOC users submit inquiries and get fast and quality assistance from a specialized team. The system accepts tickets from the website (JPay.com), the DOC user site (Facility System), JPay agents or via email. Tickets are escalated according to severity. All tickets are logged and tracked for research, training and quality assurance. JPay's Help Desk operates 24/7, providing top level support for our clients.

Once a ticket is created, the Help Desk is activated to "solve" the issue. Closing a Help Desk ticket requires two general processes. First, JPay resolves the issue (*i.e.* resetting a user's password, rebooting a kiosk, etc.) Second, JPay communicates the resolution to all stakeholders.

The account manager assigned to the DOC is copied on and responsible for all DOC tickets. Internally, the Help Desk routes each issue to the proper party for resolution, regardless of where the ticket was created. For example, a hardware technician and account manager are copied on all inquiries related to equipment.

Typical Help Desk tasks:

- Kiosk/network connectivity
- Application performance or usability
- Malfunctioning hardware
- File transmission troubleshooting
- Banking/reconciliation issues
- Specific customer cases
- Training

The JPay Help Desk team is specially trained to address all DOC concerns on JPay's product offering.



*3.4.1.5 The successful contractor must provide support for the equipment Monday through Friday 8:00 am to 5:00 pm in participating state's time zone. Vendor must provide the toll free number for agency to call when service is needed.*

The JPay Team has read, understands and agrees to comply.

The account manager assigned to the DOC is available via a toll free number during normal business hours, and reachable by cell phone 24/7/365 should the need for after hours support arise.

*3.4.1.6 Maintain levels of service and machine installation at no cost to state.*

The JPay Team has read, understands and agrees to comply.

JPay stakes its reputation on providing innovative services for correctional institutions while maintaining outstanding client and customer support, including service maintenance. JPay will provide the necessary labor, parts and materials to install and maintain all equipment in optimal working condition at no cost to the state.

*3.4.1.7 No additional installation cost for changing out machines that need repair or replacement.*

The JPay Team has read, understands and agrees to comply.

*3.4.1.8 The vendor will coordinate its service schedule in advance with the institution.*

The JPay Team has read, understands and agrees to comply.

*3.4.1.9 If ownership of equipment shall remain with the contractor, the state shall provide reasonable measures against loss by pilferage or destruction. The vendor shall be responsible for any expenses required for the repair of the equipment.*

The JPay Team has read, understands and agrees to comply.

JPay maintains ownership of all deployed equipment throughout the life of the contract and will be responsible for any expenses required for replacement or

repair.

*3.4.1.10 The successful vendor must provide following support services for equipment placed within state buildings, that include but are not limited to:*

- *Unlimited phone support;*
- *Updates and upgrades;*
- *Security-related updates to their proposed solution, which may be called updates, upgrades, patches, service packs, hot fixes, or workarounds.*

The JPay Team has read, understands and agrees to comply.

Customer service is the cornerstone of JPay’s success. As a philosophy, JPay defines the customer as the end user – everyone from the family and friends, the inmate, the correction officer, the investigator, or the released offender paying drug test fees every month. Each person using the platform in one way or another is considered a customer.

The company is continually focused on two objectives: retaining existing customers and welcoming new customers. This focus works effectively when planning and executing customer service efforts and marketing campaigns. In fact, JPay’s “A” rating from the Better Business Bureau is unrivaled in the industry.

JPay’s customer service is based on a **3 tiered** system:

**Tier 1** is the “front line” and is comprised of customer service agents who handle customer issues professionally and courteously. Unlike our competition, these bilingual agents are available to accept phone calls as well as emails 24 hours a day, 7 days a week. We believe our recurring customer base is a clear indication that the company delivers quality customer service. Testimonials to this can be seen on JPay’s forum where customers praise JPay’s phone agents and the website’s ease of use. We are happy to have fostered a customer-focused atmosphere catering specifically to inmates and their friends and families.

**Tier 2** is composed of specialized teams that focus solely on individual projects and products. For example, there is a small team that caters specifically to

support tickets written by inmates from the inmate kiosk. There is also a dedicated team that assists all facility staff at the Texas Department of Criminal Justice with their inbound eMessaging system, given that they are operating over 100 printers and go through hundreds of paper reams a month. This product specialization is relatively new to the company's structure but has quickly become an effective tool applauded by many clients.

**Tier 3** refers to software development and IT support. Any enhancements or software issues are handled by a R&D project manager and taken through the regular software update process. Any hardware or network related issues are handled by IT support. JPay has service level agreements with local technicians to handle onsite support.

### 3.5 REPORTING

*3.5.1 Vendor must include in their proposal reporting capabilities for machines to be provided, to include but not limited to the following:*

- *Processing time per transaction;*
- *Number of transactions per day;*
- *Offender purchases;*
- *The number of an individual's purchases;*
- *Transactions rejected and rejection reason;*
- *The source and amount of deposits to offender accounts;*
- *Use and statistical reports by function. (i.e. Banking queries, store sales, phone time, etc; and*
- *Be able to provide custom reports as may be requested by individual participating entities. Describe in general, the level of sophistication and complexity, custom usage report data that you can provide to the participating entities. Vendors should provide a sample report with their proposal.*

The JPay Team has read, understands and agrees to comply.

The Facility System offers a plethora of useful reports detailing inmate kiosk usage and transactional data, all of which can be exported to Excel for sorting and customization. JPay will make every attempt to develop any report not currently available at the DOC's request.

*3.5.2 Reporting shall be provided in the format required by MCPA/NASPO Reporting Forms (Attachment N).*

The JPay Team has read, understands and agrees to comply.

*3.5.3 The following usage reports shall be submitted for the respective quarter:*

- A quarterly summary of equipment sold.*
- A quarterly summary by category.*

*Reports are to be submitted to the lead State in the format required by MCPA (Attachment N).*

*Reporting Dates:*

- 1<sup>st</sup> Quarter – July – September – due by November 15<sup>th</sup>*
- 2<sup>nd</sup> Quarter – October – December – due by February 15<sup>th</sup>*
- 3<sup>rd</sup> Quarter – January – March – due by May 15<sup>th</sup>*
- 4<sup>th</sup> Quarter – April – June – due by August 15<sup>th</sup>*

The JPay Team has read, understands and agrees to comply.

### **3.6 TRAINING**

*Vendor to provide all training materials and user manuals.*

The JPay Team has read, understands and agrees to comply.

JPay takes pride in its strong training division and has successfully taught and implemented these services with corrections agency staff across the country. JPay plans to bring the expertise and experience learned from previous deployments to each DOC, offering in-depth training sessions in a variety of ways.

**Live Training** - JPay conducts in-depth, face-to-face instructional seminars both before and during the launch of the services. Simultaneous training sessions are held with trust office accountants, mailroom personnel, investigators, and all staff involved with administering JPay's services.

**Remote Training** - JPay uses WebEx to perform follow up and refresher trainings and offers supplementary remote guidance. This training is also used if additional JPay services are implemented at a correctional facility already familiar with the Facility System, or upon the DOC's request.

**Content and Literature Distribution** - Training manuals and tutorials are available on the Facility System or can be distributed via email. These are distributed during and after training sessions to familiarize users with the Facility System. A sample User Guide will be provided upon contract award.

### 3.7 SYSTEM WARRANTY

*Equipment must carry a minimum one (1) year warranty that it is free from defects in material and workmanship. If defects are identified, the successful vendor agrees to repair or replace defective parts promptly on a like-for-like basis without additional cost to the customer. Any and all items failing during the warranty period will be replaced promptly free of charge. Upon significant failure, the warranty period will commence again for a minimum 90 additional days. Significant failure shall be determined by the Participating State Contract Administrator.*

JPay provides a limited warranty with each player purchase that covers the JP3 player and all of its components for one year. During the warranty period, a malfunctioning player will be collected, repaired, and returned with the same media files present at the time it was collected. After the warranty period, JPay is not responsible for fixing or recouping broken players. JPay will work with DOC facility management to establish collection logistics.

#### LIMITED WARRANTY

The following accessories are included with the purchase of the JP3™ Player which includes the following accessories: (1) one set of ear bud headphones, (2) one AC power adaptor, and (3) one USB connector cable (collectively, the “Player”).

JPay warrants that the Player will be free from material defects in design and manufacture and will substantially conform to the published specifications under normal use for a period of 1 year following the date the Player is purchased. This warranty is provided to the recipient of the Player and is not transferable. The warranty is void if the product is not used in accordance with the product instructions, or if it is damaged as a result of misuse, unauthorized repair, modification or accident.

To obtain warranty service, a Trouble Ticket must be submitted to the JPay kiosk’s Help Desk. JPay will attempt to troubleshoot the issue. If further assistance is needed, JPay will repair or replace the product or any portion thereof with a new or refurbished product of equal or greater capacity and functionality. A replacement product assumes the remaining warranty of the original Player.

JPay does not warrant, and shall not be responsible for, any lost content or data contained in the Player regardless of the cause of the loss. JPay’s products are not warranted to operate without failure. This warranty gives you specific legal rights, and you may also have other rights which vary by jurisdiction.

JPay is not responsible for damage arising from failure to follow instructions relating to the product’s use.

This warranty does not apply: (a) to cosmetic damage, including but not limited to scratches and dents; (b) to damage caused by accident, abuse, misuse, liquid spill or submersion, flood, fire, earthquake or other external causes; (c) to damage caused by service performed by anyone who is not a representative of JPay; (d) to a Player that has been modified; or (e) to a Player that has been confiscated by correctional staff.

### 3.8 DEPARTMENT OF CORRECTIONS REQUIREMENTS

#### 3.8.1 Security

*3.8.1.1 Upon approval of the contract and prior to the start of work, each of the staff assigned by the contractor and/or subcontractor to this project may be required to sign non-disclosure agreements to be determined by each participating State.*

The JPay Team has read, understands and agrees to comply.

*3.8.1.2 All non-disclosure agreements shall be enforced and remain in force throughout the term of the contract.*

The JPay Team has read, understands and agrees to comply.

*3.8.1.3 All employees of vendors entering prison grounds must adhere to NDOC Security Regulations (Attachment K).*

The JPay Team has read, understands and agrees to comply.

#### 3.8.2 Work Area/Project Preparation

*Prior to commencement of work, the awarded vendor shall ensure that:*

- Arrangements have been made for any disposal of waste materials per Scope of Work;*
- All tools, equipment and materials are on hand; and*
- Any applicable worker training has been completed and documentation is on site required.*

The JPay Team has read, understands and agrees to comply.

#### 3.8.3 Health and Safety Standards

*3.8.3.1 The awarded vendor shall comply with all applicable federal, state, and local requirements for protecting the safety of the contractor's employees, building occupants, and the environment.*

The JPay Team has read, understands and agrees to comply.

*3.8.3.2 The awarded vendor must comply with all Federal, State and Local rules and regulations.*

The JPay Team has read, understands and agrees to comply.

*3.8.4 Employee Background Clearance Requirements*

*Upon contract award, and at least four (4) days prior to beginning work, the awarded vendor shall submit a completed Contractors Background Check Applications (Attachment M), Consent for Release of Criminal History Records form (DOC560) for each employee who will be working on this project (unless previously cleared for the Site Visit).*

The JPay Team has read, understands and agrees to comply.

**3.9 OPTIONAL/OTHER SERVICES**

*Vendor may submit additional options. Options must be listed in detail.*

The JPay Team has read, understands and agrees to comply.

The Intel System

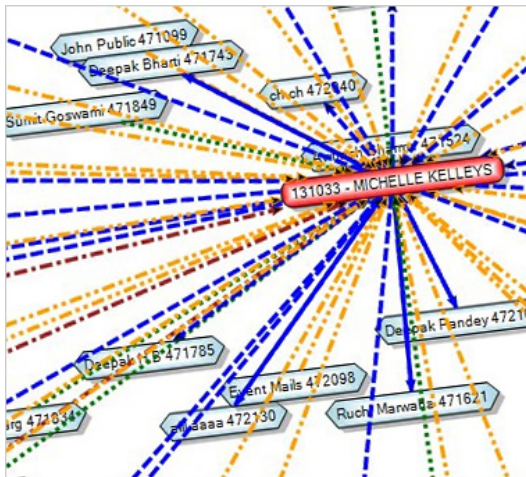

Today's latest data mining techniques are deployed to get the best business intelligence from the vast amount of transactional data collected on the JPay platform. JPay's Intel System, an ever-growing set of online tools (bundled free with JPay's offering), is used on a daily basis by correction agencies nationwide for profiling, fraud detection, surveillance and criminal investigations. Intel teams are given tools to detect networks and relationships that are deemed suspicious and need immediate attention.



### Customized Alerts

Correctional staff can customize their own set of alerts based on inmate and customer activity. For example, a staff member may choose to receive an alert if multiple inmates are receiving eMessages or money from one customer. The JPay system will alert the staff member via email or SMS whenever this customer uses the system to send a deposit or eMessage to an inmate. This introduces an unprecedented level of detection capability to correctional staff.

### Cross Jurisdictional Analysis

Another element of data mining lies in the data management itself. JPay currently works with over 20 state correctional agencies and numerous county agencies throughout the country. In conformance with each agency's rules and regulations, JPay is able to share a majority of jurisdictions with users who generate cross-border investigation results. This has been a tremendous success for bordering corrections agencies. When investigations are under way, investigators will often require detailed information about the transactions that took place outside of their jurisdiction. Gang activity has been uncovered on multiple occasions using this shared information.

### Graphical Mapping

What used to take investigators countless hours is performed with the click of a button, and using a subset of data far greater than any human can analyze. With the Intel Mapping feature investigators can quickly see an inmate or customer's transactional network saving hundreds of hours spent per incident or case.

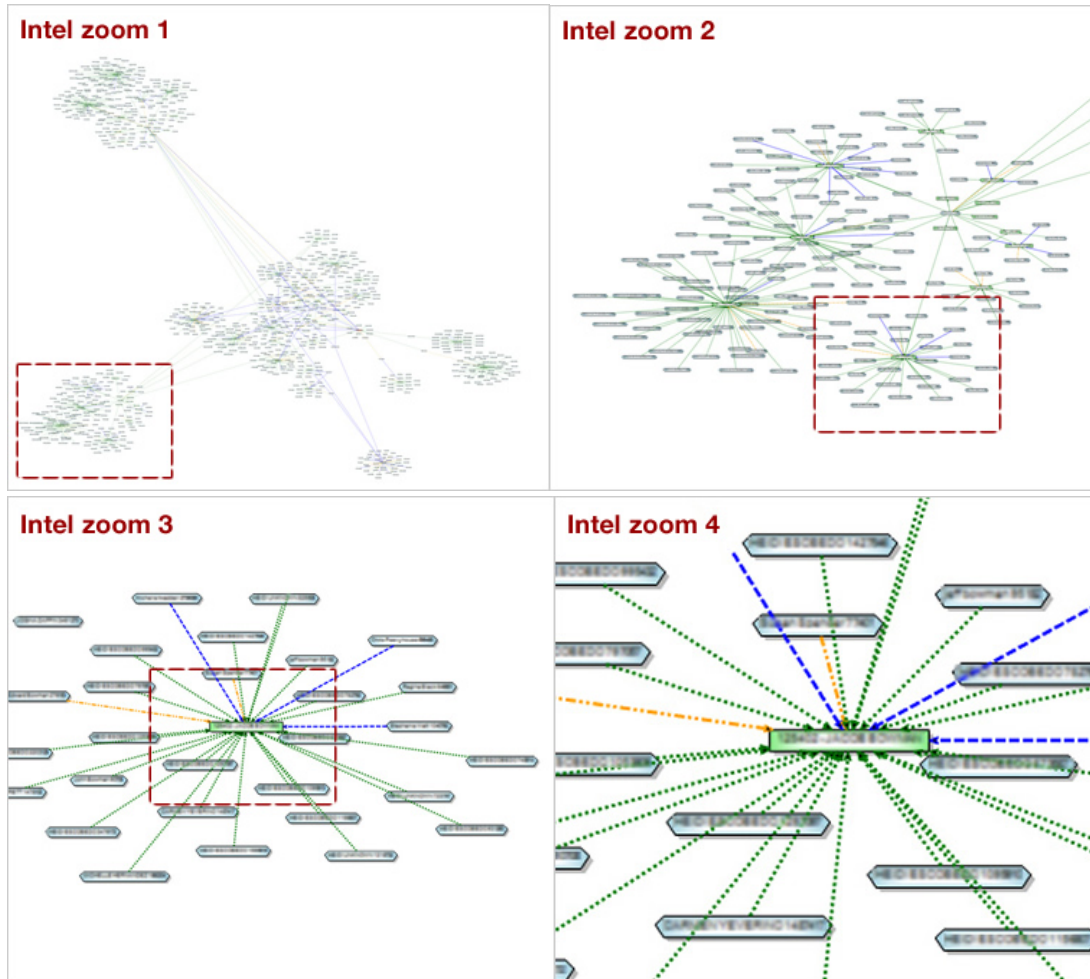

Investigators can use this tool to identify gangs or other Security Threat Groups. In addition, financiers or other members of the group on the outside are not only identified but their full transaction history or eMessage history is at the investigators fingertips. This system has proven itself time and time again in correctional agencies across the country.

### 3.10 DOCUMENTATION

*3.10.1 Detailed technical system documentation and system design specifications, descriptions of all proposed kiosk hardware and software, operating instructions, footprints, power and environmental requirements, model numbers, makes, serial numbers, electrical and grounding requirements, temperature and humidity ranges, software components and features, etc.*

The JPay Team has read, understands and agrees to comply.

Attached please find the following documentation:

- JP3 User Manual
- Kiosk “How-To” Signage
- JPay Change Management Plan

*3.10.2 As applicable, prior to production implementation, the successful vendor shall provide to the DOC detailed technical system documentation, detailed system design specifications, descriptions of all proposed kiosk hardware and software, operating instructions, footprints, power and environmental requirements, model numbers, makes, serial numbers, electrical and grounding requirements, temperature and humidity ranges, software components and features, etc.*

The JPay Team has read, understands and agrees to comply.

Additional documentation shall be provided prior to production implementation.

## 4. PROJECT TERMS AND CONDITIONS

### *4.1 Contractual Special Terms and Conditions*

*4.1.1 Participating Addendum – Individual Participating States may, through a Participating Addendum, limit:*

*4.1.1.1 The awardees;*

The JPay Team has read, understands and agrees to comply.

*4.1.1.2 Available financial vehicles;*

The JPay Team has read, understands and agrees to comply.

*4.1.1.3 Equipment Groupings, segments, models, standardized configurations, available accessories, available software;*

The JPay Team has read, understands and agrees to comply.

*4.1.1.4 Exclusion of geographical areas;*

The JPay Team has read, understands and agrees to comply.

*4.1.1.5 As well as additional items as deemed necessary by the Participating State.*

The JPay Team has read, understands and agrees to comply.

*4.1.1.6 States may also, through the Participating Addendum, expand or restrict these options for Participating Political Subdivisions.*

The JPay Team has read, understands and agrees to comply.

## 5. COMPANY BACKGROUND AND REFERENCES

### 5.1 PRIMARY VENDOR INFORMATION

Vendors must provide a company profile. Information provided shall include:

#### 5.1.1 Company ownership (sole proprietor, partnership, etc).

5.1.1.1 Incorporated companies must identify the state in which the company is incorporated and the date of incorporation. ***Please be advised***, pursuant to NRS §80.010, incorporated companies must register with the State of Nevada, Secretary of State’s Office as a foreign corporation before a contract can be executed between the State of Nevada and the awarded vendor, unless specifically exempted by NRS §80.015.

JPay Inc. was incorporated on December 3, 2002 in the State of Delaware. JPay is registered as a foreign corporation with the State of Nevada Secretary of State’s Office, Entity # E0237802011-8.

5.1.1.2 The selected vendor, prior to doing business in the State of Nevada, must be appropriately licensed by the Office of the Secretary of State pursuant to NRS §76. Information regarding the Nevada Business License can be located at <http://sos.state.nv.us>. Vendor’s must provide the following:

- Nevada Business License Number

NV20111282456

- Legal Entity Name

JPay Inc.

- Is “Legal Entity Name” the same name as vendor is doing business as?

Yes  No

5.1.2 Disclosure of any alleged significant prior or ongoing contract failures, contract breaches, any civil or criminal litigation or investigation pending which involves the vendor or in which the vendor has been judged guilty or liable with the State of Nevada.

JPay has no significant prior or ongoing contract failures, contract breaches, any civil or criminal litigation or investigations pending and has never been judged guilty or liable with the State of Nevada.

*5.1.3 Location(s) of the company offices and location of the office that will provide the services described in this RFP.*

All services described in this RFP will be provided from JPay's Corporate Offices located in Miami, Florida.

*5.1.4 Number of employees both locally and nationally.*

JPay has approximately 110 employees both locally and nationally.

*5.1.5 Location(s) from which employees will be assigned.*

Employees will be assigned from JPay's Corporate Office in Miami.

*5.1.6 Name, address and telephone number of the vendor's point of contact for a contract resulting from this RFP.*

Errol Feldman  
JPay Inc.  
12864 Biscayne Blvd., Ste 243  
Miami, FL 33181  
Tel: 305.577.5543

*5.1.7 Company background/history and why vendor is qualified to provide the services described in this RFP.*

In 2002, as the dust settled from the dot-com bust, JPay was created with the mission to ease the burdens associated with inmate living by building and delivering smart and scalable software applications for the prison environment. The company first introduced a money transfer platform for trust account deposits, eventually complimenting the product with an inmate email system and then closed the gap by developing the complete inmate kiosk platform. Kiosk applications have been introduced one at a time and now include digital music delivery, Internet video visitation, inmate banking, commissary ordering and other various custom applications requested over time by our correctional partners.

Here is why JPay is better than the competition:

1. Our kiosks are designed to host each application and designed to be placed through the housing units of the facilities, making every application easily accessible to every inmate. This model allows for maximum exposure of the program to the DOC's inmates. Without this exposure, adoption and continued usage would be minimal, as is evidenced in the competitors' low adoption/usage.
2. Besides having the kiosk with all its applications readily available to all inmates, JPay prices its JP3 player at a price that is affordable to everyone. This approach garners huge adoption, as is evidenced by the company's recent rollout.
3. We develop and maintain all of our applications in-house. Typically, large companies who do not specialize in this product offering partner with a third party to provide the service. As a result, the integration is rocky, there is a degradation in customer service, the product suffers and ultimately the DOC suffers. JPay is in full control of its product – from design to deployment.
4. By controlling our development resources, JPay has the ability to enhance its product in ways others cannot. This puts JPay in the best position to offer products that the DOC may envision.
5. Inmate Services is our core business. No other company in the field can say the same.

*5.1.8 Length of time vendor has been providing services described in this RFP to the public and/or private sector. Please provide a brief description.*

For the past 9 years, JPay has been offering its services exclusively to the corrections industry including government agencies as well as private prisons.

*5.1.9 Has the vendor ever been engaged under contract by any State of Nevada agency?*

*[X] Yes [ ] No If "Yes," specify when, for what duties, and for which agency.*

JPay has been providing electronic fund transfer for the Nevada Department of Corrections since 2003. In 2009 JPay also began offering inbound eMessaging and debit cards for released offenders.

*5.1.10 Is the vendor or any of the vendor's employees employed by the State of Nevada, any of its political subdivisions or by any other government?*

*[ ] Yes [X] No*

*5.1.11 Resumes for key staff to be responsible for performance of any contract resulting from this RFP.*

## Lee Posner, Client Services Manager

12864 Biscayne Blvd • Ste 243 • Miami, FL 33181  
305.358.8689 Ext. 250 • [lposner@jpay.com](mailto:lposner@jpay.com)

---

<b>Experience</b>	<b>JPay Inc. Miami, FL</b> <i>Manager, Client Services</i> <ul style="list-style-type: none"><li>• Heads team of 7 client service professionals</li><li>• Responsible for overall relationship</li><li>• Implementation, training, marketing, troubleshooting</li><li>• Recent Deployments: Illinois DOC, Washington DOC and the Kansas DOC</li></ul>	Sept. 2008- Present
	<b>Flagship Games International Hollywood, FL</b> <i>Director of Shipboard Programs</i> <ul style="list-style-type: none"><li>• Created/implemented training to familiarize teams with ship's procedures</li><li>• Designed innovative programs which increased revenue by 15%</li><li>• Communicated with individual ship-based contacts to develop new programs</li></ul>	Nov. 2006 - Feb. 2008
<b>Education</b>	<b>University of Florida Gainesville, FL</b> <i>Bachelor of Arts</i> Major - Criminology	May 2002
<b>Reference</b>	<b>North Dakota Department of Corrections</b> <ul style="list-style-type: none"><li>• Successfully deployed eMessaging statewide in 45 days</li><li>• Received exceptional reviews from the State</li></ul>	Nov. 2008- Present
	<b>Kansas Department of Corrections</b> <ul style="list-style-type: none"><li>• Deployed electronic trust account deposits and inbound eMessaging</li><li>• Supervises the installation of inmate kiosks statewide</li></ul>	Jan. 2009- Present
	<b>Ohio Department of Rehabilitation &amp; Correction</b> <ul style="list-style-type: none"><li>• Deployed electronic trust account deposits and eMessaging</li><li>• Trains the DOC staff on how to use Facility System</li></ul>	Oct. 2009- Present



## Jessica Goeden, Program Manager

12864 Biscayne Blvd • Ste 243 • Miami, FL 33181

305.358.8689 Ext. 338 • [JGoeden@jpay.com](mailto:JGoeden@jpay.com)

---

- Experience**
- JPay Inc. Miami, FL** Dec. 2009- Present  
*Program Manager – Professional Services*
- Provides around the clock, exceptional customer service to correction agencies throughout the United States
  - Trains and supports the needs of correctional facility staff via live training and WebEx
  - Assists IT department both for maintenance and support
- Cormark, Inc. Des Plaines, IL** Jan. 2003- Aug. 2009  
*Project Manager*
- Negotiated with vendors to achieve the best possible material costs to procure bids
  - Organized production lines to insure quality and time efficiency
  - Analyzed project time lines with the assistance of Gantt Charts to produce estimates
  - Worked with overseas factories to manage cost, production quality, and shipping requirements
  - Corrected inventory issues within our ERP system
  - Developed, assembled, and presented prototypes to clients
  - Directed fellow project managers in proper usage of Visual
  - Streamlined a \$3 million project supply chain resulting in a 50% decrease in inventory overhead
- Education**
- Coast Carolina University Conway, SC** Aug. 2006  
*Bachelor of Science*  
Major- Business
- Reference**
- Ohio Department of Rehabilitation and Correction** Dec. 2009- Present
- Designed Facility System Parameters based on DOC administrative requirements
  - Trains offenders on all aspects of the eMessaging Program
- Kansas Department of Corrections** Dec. 2009- Present
- Provides technical support to DOC staff at Facilities statewide
  - Supervised installation and deployment of offender kiosks

## Nestor Nuñez, Jr., Client Services Engineer

12864 Biscayne Blvd • Ste 243 • Miami, FL 33181

305.358.8689 Ext. 321 • [nnunez@jpay.com](mailto:nnunez@jpay.com)

---

<b>Experience</b>	<b>JPay Inc. Miami, FL</b> <i>Client Services Engineer</i> <ul style="list-style-type: none"><li>Plans and executes deployment functions for inmate kiosks in assigned statewide correctional systems</li><li>Oversees and monitors operational status of kiosks nationwide</li><li>Gathers and reports Network Operations Center (NOC) level status of all inmate and lobby kiosks</li><li>Quality assurance for server functionality, agency configuration and hardware setup</li></ul>	Nov. 2009- Present
	<b>Lloyds Banking Group Miami, FL</b> <i>IT Support Analyst</i> <ul style="list-style-type: none"><li>Intercepted and resolved all incoming IT issues for customers before escalation</li><li>Monitored crucial operational servers and systems</li><li>Completed data retention and rotation procedures</li><li>Coordinated all Help Desk projects</li></ul>	Aug. 2007- Aug. 2009
<b>Education</b>	<b>Georgia College Milledgeville, GA</b> <i>Master of Business Administration</i>  <b>University of Florida Gainesville, FL</b> <i>Bachelor of Science</i> Major- Information Systems and Operations Management	May 2006  May 2003
<b>Reference</b>	<b>Kansas Department of Corrections</b> <ul style="list-style-type: none"><li>Trains internal IT staff as well as inmates following deployment of inmate kiosks statewide</li><li>Troubleshoots network connectivity</li><li>Designed equipment reboot methodology for remote maintenance</li></ul> <b>Texas Department of Criminal Justice</b> <ul style="list-style-type: none"><li>Supervised installation of kite scanners in over 100 facilities</li><li>Remotely monitor and repair onsite hardware and software</li></ul>	Nov. 2009- Present  Jan. 2010- Present

## Javier Pico, IT Integrations Support Manager

12864 Biscayne Blvd • Ste 243 • Miami, FL 33181

305.358.8689 Ext. 229 • [jpico@jpay.com](mailto:jpico@jpay.com)

---

**Experience**    **JPay Inc. Miami, FL**    Sept. 2005- Present  
*IT Support*

- Provides upper tier technical and customer support
- Oversees daily technical file transfers between JPay and clients
- Installs and troubleshoots on-site and off-site technical equipment
- Over 4 years of technical help desk experience specifically for correctional facilities

**Sunshine Call Center Coral Gables, FL**    Mar. 2003- Aug. 2005  
*Assistant Engineer*

- Responsible for PBX and voice over IP technology
- Designed and implemented new call recording systems
- Supervised training for new hires
- Maintained emergency response computer repair team

**Education**    **Miami Dade College Miami, FL**    May 2008  
Major- Computer Information Systems

**Reference**    **Illinois Department of Corrections**    Dec. 2009- Present

- Oversees daily deposit file transfer for Electronic Deposits between the DOC and JPay
- Provides technical support to DOC staff

**Indiana Department of Correction**    Oct. 2007- Present

- Provides upper level technical help desk support to DOC facilities
- Manages daily file transfers

*5.1.12 Financial information and documentation to be included in Part III of your response in accordance with the Submittal Instructions.*

This information has been provided under separate cover, as requested.

## **5.2 REFERENCES**

*Vendors should provide a minimum of three (3) references from similar projects performed for private, state and/or large local government clients within the last three years.*

JPay requested that the following three clients submit references directly to the Purchasing Division:

### *5.2.1 Client name;*

Georgia Department of Corrections

### *5.2.2 Project description;*

JPay collects inmate trust account deposits, community supervision deposits and release debit cards for the DOC. JPay also provides inmate kiosks at several facilities that let inmates download music onto a JP3 player, send and receive eMessages and conduct video visits.

### *5.2.3 Project dates (starting and ending);*

January 2009 - Present

### *5.2.4 Technical environment; (i.e., Software applications, Internet capabilities, Data communications, Network, Hardware)*

JPay has installed wireless mesh networks at facilities where inmate kiosks are deployed.

### *5.2.5 Staff assigned to reference engagement that will be designated for work per this RFP; and*

Lee Posner, Manager Client Services  
Jessica Goeden, Program Manager  
Javier Pico, IT Integrations Support Manager

*5.2.6 Client project manager name, telephone number, fax number and e-mail address.*

Name: Mitzi J. Richards  
Tel: 478.992.6287  
Fax: 404.463.1792  
Email: [richam00@dcor.state.ga.us](mailto:richam00@dcor.state.ga.us)

*5.2.1 Client name;*

Michigan Department of Corrections

*5.2.2 Project description;*

JPay has provided electronic deposits and inbound eMessaging solutions statewide since February 2009 and added release debit cards in March 2009. JPay's inmate kiosks are installed across several facilities throughout the State that let inmates view and send outbound eMessages.

*5.2.3 Project dates (starting and ending);*

February 2009 - Present

*5.2.4 Technical environment; (i.e., Software applications, Internet capabilities, Data communications, Network, Hardware)*

JPay has installed wireless mesh networks at facilities where inmate kiosks are deployed.

*5.2.5 Staff assigned to reference engagement that will be designated for work per this RFP; and*

Lee Posner, Manager Client Services  
Jessica Goeden, Program Manager

Javier Pico, IT Integrations Support Manager

*5.2.6 Client project manager name, telephone number, fax number and e-mail address.*

Name: Deborah Kline  
Tel: 517.373.3821  
Fax: 517.373.3882  
Email: [klineda@michigan.gov](mailto:klineda@michigan.gov)

*5.2.1 Client name;*

North Dakota Department of Corrections

*5.2.2 Project description;*

JPay provides two-way eMessaging via inmate kiosks.

*5.2.3 Project dates (starting and ending);*

September 2008 – Present

*5.2.4 Technical environment; (i.e., Software applications, Internet capabilities, Data communications, Network, Hardware)*

In order to best accommodate the existing infrastructure in North Dakota, JPay's inmate kiosks operate through a variety of technical environments. Three facilities operate strictly on JPay-provided networks, two of which are wireless while the other uses a cable connection. A fourth facility allows JPay to use the DOC's network.

*5.2.5 Staff assigned to reference engagement that will be designated for work per this RFP; and*

Lee Posner, Manager Client Services  
Javier Pico, IT Integrations Support Manager

*5.2.6 Client project manager name, telephone number, fax number and e-mail address.*

Name: Patrick D. Branson

Tel: 701.328.6214

Fax: 701.328.6651

Email: [pbranson@nd.gov](mailto:pbranson@nd.gov)

### **5.3 SUBCONTRACTOR INFORMATION**

*5.3.1 Does this proposal include the use of subcontractors?*

Yes \_\_\_\_\_ No X Unknown \_\_\_\_\_

## 6. STATE DOCUMENTS