

UNCLASSIFIED//~~FOR OFFICIAL USE ONLY~~



Defense Intelligence Reference Document

Acquisition Threat Support

2 March 2010

ICOD: 1 December 2009

DIA-08-1003-002

Positron Aerospace Propulsion

UNCLASSIFIED//~~FOR OFFICIAL USE ONLY~~

Positron Aerospace Propulsion

Prepared by:

(b)(3):10 USC 424

Defense Intelligence Agency

Author:

(b)(6)

Administrative Note

COPYRIGHT WARNING: Further dissemination of the photographs in this publication is not authorized.

This product is one in a series of advanced technology reports produced in FY 2009 under the Defense Intelligence Agency, (b)(3):10 USC 424 Advanced Aerospace Weapon System Applications (AAWSA) Program. Comments or questions pertaining to this document should be addressed to (b)(3):10 USC 424:(b)(6) AAWSA Program Manager, Defense Intelligence Agency, ATTN: (b)(3):10 USC 424 Bldg 6000, Washington, DC 20340-5100.

Contents

Introduction.....	v
Antimatter.....	1
Positron Air-Breathing Propulsion.....	2
PTRE Applications	5
Unmanned Aerial Vehicle (UAV)	5
Ramjet-Assisted Missile (RAM)	7
Single-Stage Reusable Vehicle (SSRV)	8
Positron-Powered Rockets	11
The Solid-Core Positron Rocket.....	12
The Gas-Core Positron Rocket	14
The Sanger Photon Positron Rocket	16
Positron Rocket System Comparison.....	17
Positron Energy Conversion for Onboard Power.....	18
Positrons for a Manned Mars Mission	19
Positron Production.....	22
Positron Costs	23
Positron Storage	24
Formation of Positronium in Porous Media.....	25
Long-Term Storage of Positronium	25
Conclusions.....	27

Figures

Figure 1. Specific Energy for Chemical, Nuclear and Antimatter Materials:.....	1
Figure 2. Tory-IIC Ready for Testing	3
Figure 3. PTRE Turbojet and Turbo-Ramjet Modes	3
Figure 4. Details of the PTRE Engine.	4
Figure 5. Combustion Turbo-Ramjet.....	4
Figure 6. UAV Range vs. Positron Mass	5
Figure 7. LOCAAS Turbojet Engine	6

Figure 8. BOMARC and Talos Ramjet-Assisted Missiles..... 8
Figure 9. Positron SSRV Flight Profile 10
Figure 10. Artist’s Rendition of a Four-Engine Positron SSRV..... 11
Figure 11. Solid-Core Positron Rocket Engine With a Hot-Bleed Configuration..... 12
Figure 12. Fluid Systems 15
Figure 13. Modified Sänger Photon Rocket Concept 17
Figure 14. Closed Brayton Cycle Using Positron Annihilation 18
**Figure 15. Conceptual 110 Watt Positron Closed Cycle Generator Based on the
NASA Glenn Research Center Stirling Radioisotope Generator (SRG) .. 18**
Figure 16. Mars Trajectories (X-Coordinates Defined in Direction of Aries) 20
Figure 17. Spacecrafts Using Positron Engines..... 21
**Figure 18. Proposed Undulator-Based Positron Source for the International
Linear Collider 22**
Figure 19. Penning Trap 24
Figure 20. A Positron Forms Ps 25
Figure 21. Computer Simulation of Ps Atoms 26
Figure 22. TEM of Silica Aerogel 26

Tables

Table 1. GLOW for Chemical SSRV 9
Table 2. GLOW for Positron SSRV 9
Table 3. Total Positron Requirement for SSRV With a Dry Mass of 60,500 kg..... 10
Table 4. Comparison of Space Propulsion and Power Systems – Solid Core 13
Table 5. Comparison of Three Positron Propulsion Concepts for Mars Mission 17
Table 6. Positron and Antiproton Expected Costs in the Next 10 Years 23

Positron Aerospace Propulsion

Introduction

Antimatter is considered an extremely attractive fuel for aerospace propulsion because of its enormous advantage in energy density over all other known sources of energy. However, because antimatter does not occur naturally and is unstable in the presence of matter, no vehicles have ever flown using it.

After a short overview of the various aerospace applications of antimatter, this paper provides a detailed analysis of air-breathing turbojets and turbo-ramjet missiles, as well as rockets for manned interplanetary missions. It discusses new methods of producing and storing large numbers of antielectrons, or positrons, and compares their costs with those of antiprotons. Finally, the paper considers the prospects for the first, modest demonstration of positron propulsive flight within the next 10 years. Interplanetary missions on positron-propelled spaceships are described in detail, with estimates of positron requirements for each mission. Standalone positron power systems are described briefly.

Studies of positrons as a fuel for aerospace propulsion applications have been sponsored by the Air Force Research Laboratory, Eglin Air Force Base, Florida, and the NASA Institute for Advanced Concepts, Atlanta, Georgia. This paper is an anthology of that work and not a general review of antimatter propulsion.

The positron was predicted by Dirac in 1929¹ and discovered by Anderson in 1932.² Along with the antiproton, which was discovered in 1954,³ the positron has the largest specific energy of any known material. Because aerospace propulsion performance is ultimately limited by specific power, this advantage was immediately appreciated. However, compared with chemical sources of energy, positrons presented new and serious production and storage challenges.

Antimatter has a long history of appearing in science fiction literature, dating to a 1942 short story in *Astounding Science Fiction* and the 1949 book *Seetee*. It later appeared in the *Star Trek* television and film series and continues to be an appealing subject for contemporary books and films, such as *Angels and Demons*.

Positron aerospace propulsion is now entering a critical period owing to new technologies that bear on production and storage issues. To their advantage, positrons, unlike nuclear fission and antiprotons, present no radiation or environmental safety problems.

Antimatter

Antimatter appears in the form of fundamental particles that have their sign of electric charge reversed from their matter counterpart. For example, the positron, e^+ , is the antiparticle to the electron, e^- . According to the CPT theorem,⁴ properties of matter and their counterpart antimatter particles are identical. This has been tested in the laboratory to an accuracy of roughly 1 part in 10 million.

Antimatter is appealing for aerospace uses because its specific energy by annihilation is 180 MJ/ μ g, or 10 orders of magnitude larger than chemical energy, as shown in Figure 1.

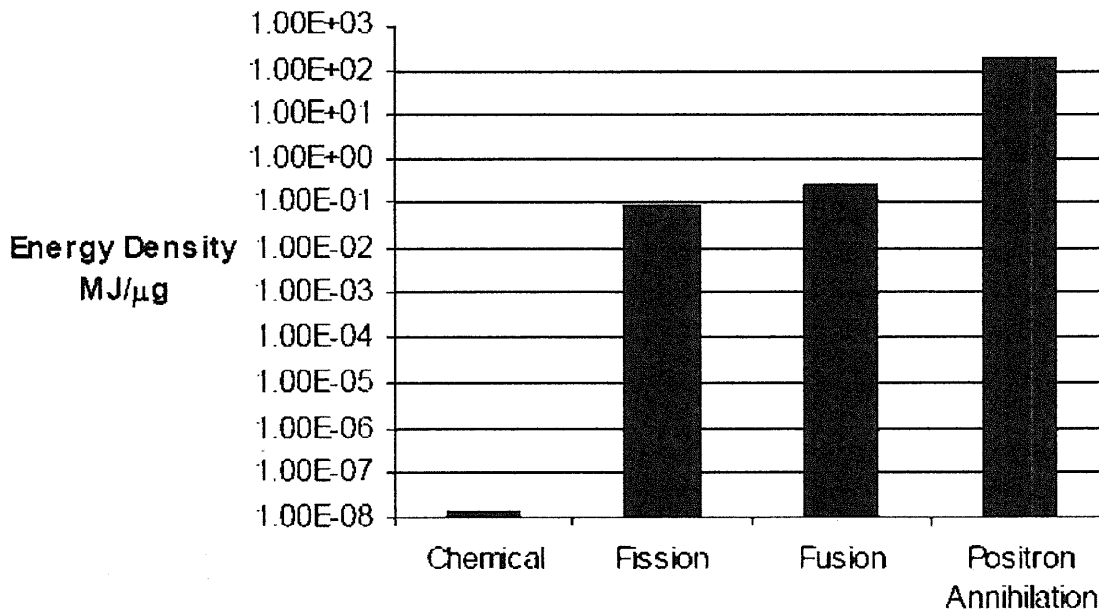

Figure 1. Specific Energy for Chemical, Nuclear, and Antimatter Materials

In the presence of matter, the positron binds with an electron to form a short-lived atom called positronium (Ps). Depending on the relative spin orientations of the positron and electron, Ps has a mean lifetime in a vacuum of 125 picoseconds (para-Ps, spins antiparallel), or 142 nanoseconds (ortho-Ps, spins parallel).

From quantum number conservation, para-Ps decays into two gamma rays of equal energy, 511 kiloelectronvolts (keV), whereas ortho-Ps decays into three gamma rays whose energies add up to 1022 keV. Hence, when Ps self-annihilates, there is 100 percent conversion of mass into electromagnetic energy given by Einstein's famous equation, $E = mc^2$, where c is the speed of light.

Although the energies of positron annihilation gamma rays are on the nuclear scale, they have none of the undesirable features associated with nuclear energy. First, the annihilation evolves rapidly (nanoseconds) and is controllable under predictable electromagnetic forces. There is no long-term inertia as with nuclear reactors. Consequently, positron-generated thrust can be throttled.

Second, low-energy gamma rays from positron annihilation cannot make residual radioactivity in surrounding air and containment vessels. In contrast, antiprotons annihilate into a host of high-energy particles, including π -mesons and gamma rays that can induce residual radioactivity in nearby materials.

Finally, low-energy gamma rays from positron annihilation can be readily converted into useful forms of energy, including heat and electricity required for propulsion systems. This contrasts with large, complex systems required for conversion of antiproton annihilation and nuclear fission/fusion energy.

There are two reasons why positrons have yet to be used for aerospace applications. First, it has not been possible to produce them in the numbers required. However, recent developments in high-energy physics research are resulting in expanding levels of positron production. Second, methods for storing positrons for basic research do not hold enough positrons long enough for propulsion applications. Recent developments in storage techniques may significantly improve the situation, with lifetimes up to months and possibly years.

Positron Air-Breathing Propulsion

Aeronautical engines burn a mixture of aviation fuel and oxygen in air to heat a working fluid. To keep engines small, the combustion rate in the engine needs to be high.⁵ At sea level for a fuel-air mass ratio of 0.068, it is 500,000 kJ/m³-s. To maintain speed, the thrust specific fuel consumption (TSFC) for turbojets and turbo-ramjets is in the range of 0.075 - 0.11 and 0.17 - 0.26 kilogram/hour-Newton (kg/hr-N), respectively. All aeronautical engines are limited in range and flight duration by the fuel on board.

Because of the aforementioned performance bounds of combustion engines, the aeronautic industry has worked diligently to increase the range and payload of aircraft by maximizing the performance of combustion engines and optimizing aerodynamic design. Beyond this, the only way a combustion-powered aircraft can extend its range and endurance is by in-flight refueling.

Two projects investigated nuclear power as a way to increase performance. In 1946, the U.S. Air Force established the Nuclear Energy for Propulsion of Aircraft program. However, this program was disbanded in 1951 in favor of the joint Atomic Energy Commission-Air Force Aircraft Nuclear Propulsion program. Implementing nuclear fission to power an aircraft required two approaches. One was direct cycle, whereby air was heated by passing it through a nuclear reactor; the other was indirect cycle, whereby the reactor heated a liquid metal that in turn heated air in a secondary heat exchanger. The program never produced a prototype and was canceled in 1961.

In 1957, the Pentagon started development of a nuclear ramjet missile (SLAM, Supersonic Low-Altitude Missile) to fly below Soviet defenses. The Lawrence Livermore National Laboratory Pluto program successfully tested two engines, Tory-IIA and Tory-IIC (Figure 2), at the Nevada Test Site. The program was canceled in 1964.^{6, 7}

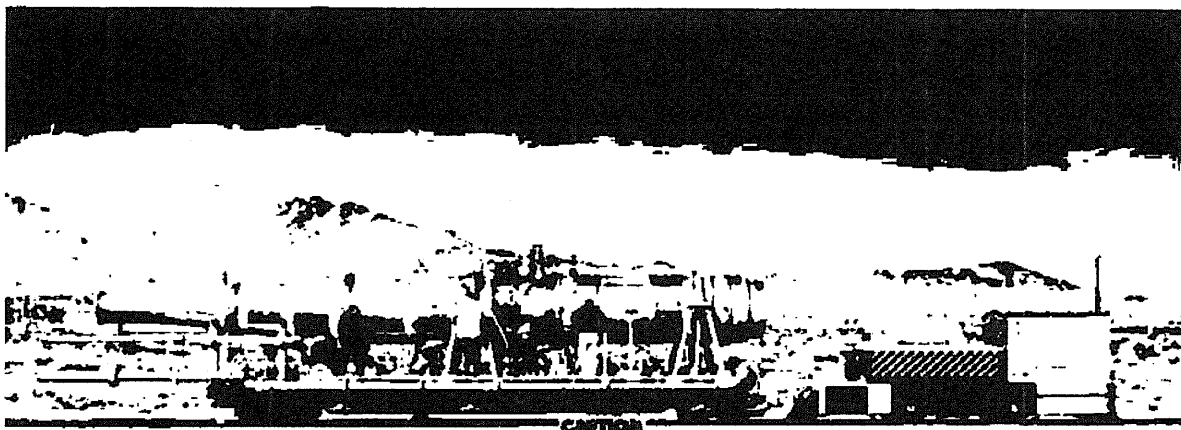

Figure 2. Tory-IIC Ready for Testing (courtesy LLNL)

In a positron turbojet/ramjet engine (PTRE),⁸ tungsten shells are heated by gamma rays, with heat transferred to air by convection.^{9, 10}

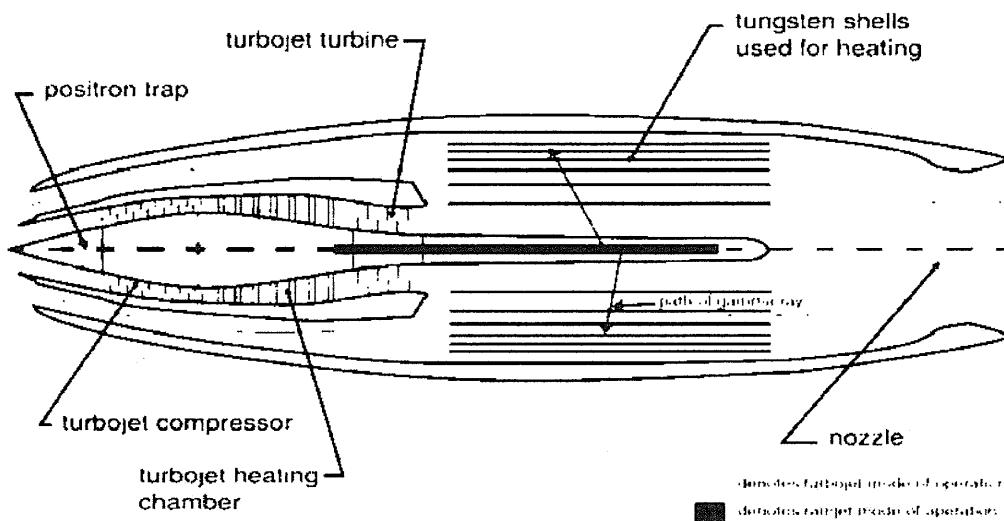

Figure 3. PTRE Turbojet (green) and Turbo-Ramjet (red) Modes (courtesy Positronics Research LLC)¹¹

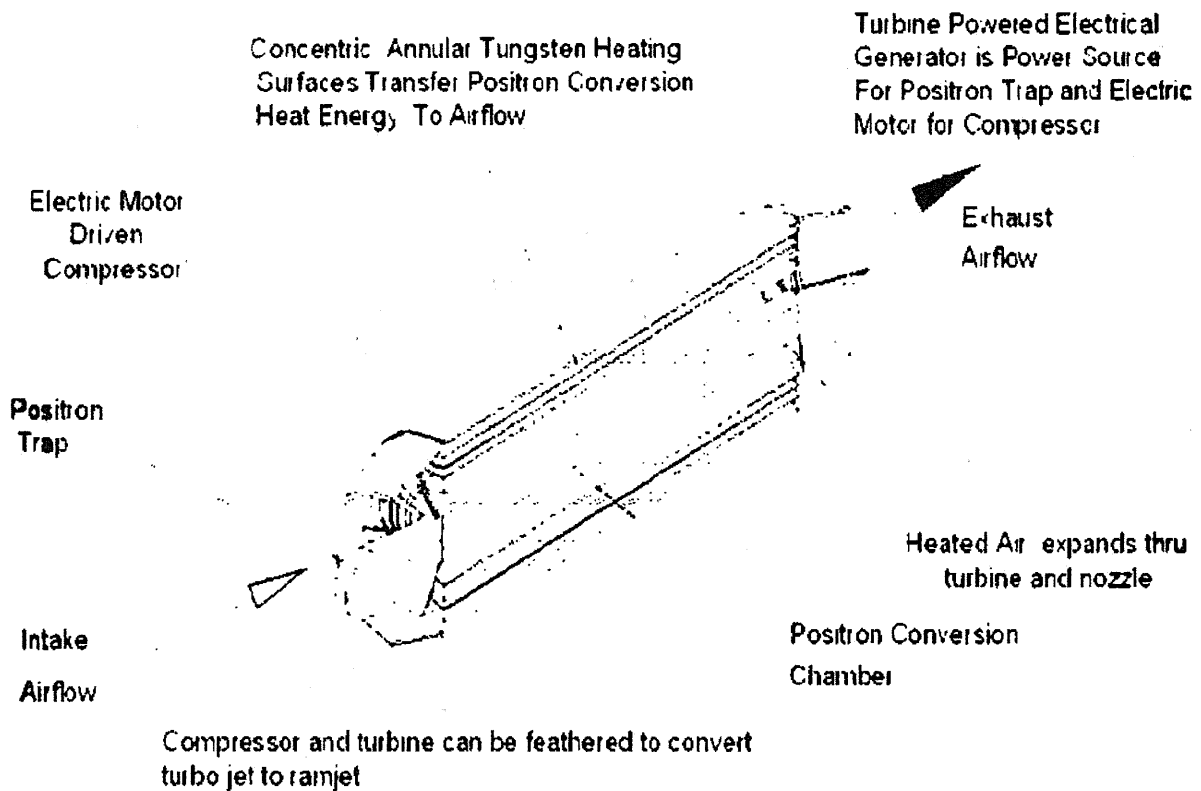

Figure 4. Details of the PTRE Engine (courtesy Positronics Research LLC)¹²

A comparison with the combustion turbo-ramjet engine (Figure 5) shows that volume used for combustion heating is used by PTREs for convection heating.

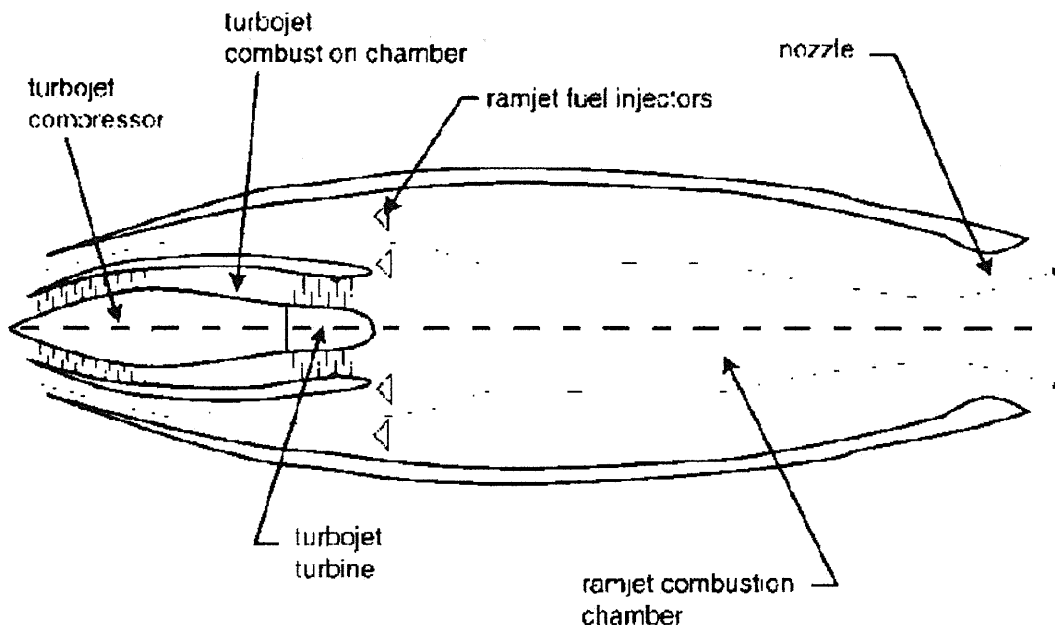

Figure 5. Combustion Turbo-Ramjet (courtesy Positronics Research LLC)¹³

PTRE Applications

Three uses for PTREs have been investigated: unmanned aerial vehicles (UAVs), ramjet-assisted missiles (RAMs), and single-stage reusable vehicles (SSRVs).

UNMANNED AERIAL VEHICLE (UAV)

Figure 6 shows range versus positron mass for a 60-kg UAV with lift/drag of four that can circumnavigate Earth on 150 μg of positrons.¹⁴ It is modeled after the LOCASS turbojet (Figure 7) at the Air Force Research Laboratory (AFRL), Eglin Air Force Base, Florida.¹⁵

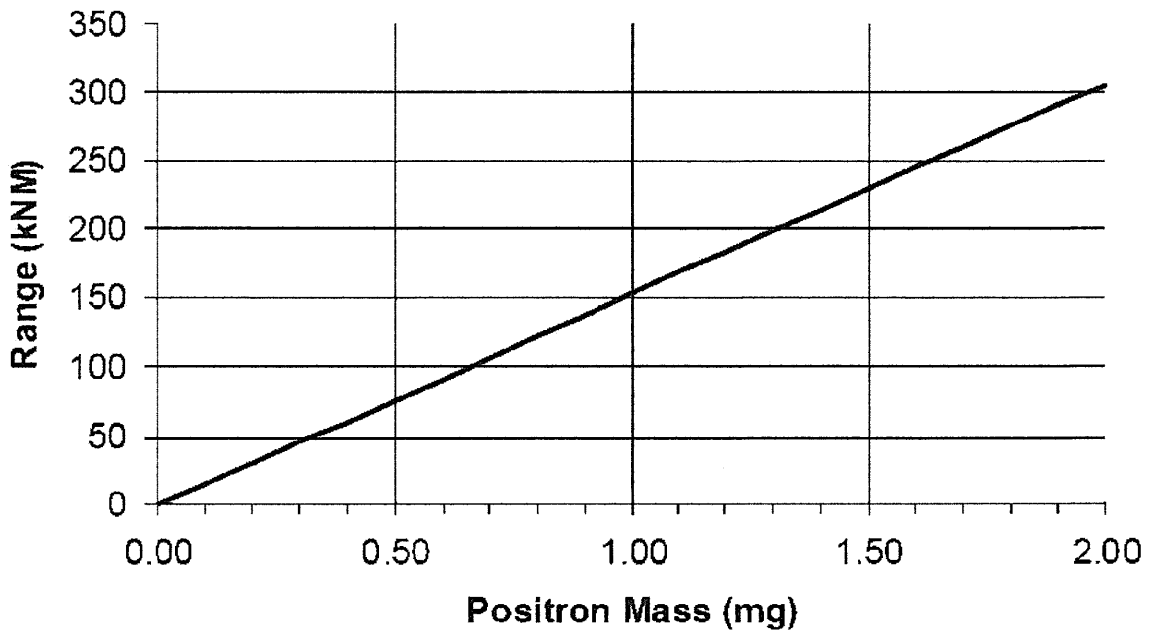

Figure 6. UAV Range Versus Positron Mass (courtesy Positronics Research LLC)¹⁶

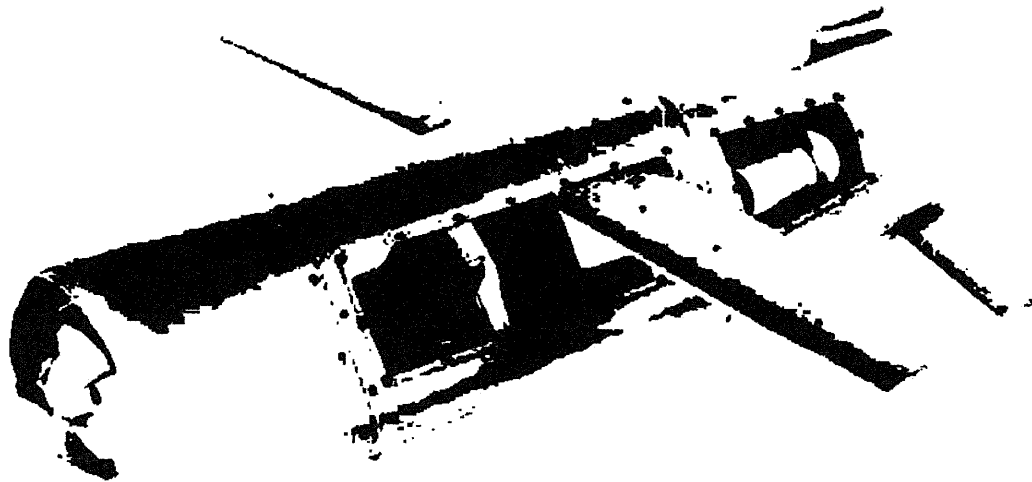

Figure 7. LOCAAS Turbojet Engine (courtesy of AFRL, Eglin AFB, FL)¹⁷

A UAV fueled with positrons would allow for an ultralong-endurance platform with many “dual-use” applications, including the following:

Military

- Intelligence, surveillance, and reconnaissance.
- Real-time battlefield command observation.
- Monitoring and early warning of nuclear, biological, and chemical weapons.
- Ordnance delivery.
- Target laser illumination/covert target acquisition.
- Coastal patrol.
- Drug interdiction.
- Search and rescue.
- Geomagnetic and atmospheric surveys.

Civil, State, and Local Government

- Airborne early warning (storms, terrorist attacks, chemical/biological/nuclear).

- Environmental/pollution monitoring.
- Fire detection and monitoring.
- Aerial surveying.
- Weather and atmospheric monitoring.
- Border patrol.
- Emergency communications relay.
- Drug interdiction.
- Law enforcement.
- Highway/road monitoring.
- Search and rescue.

Commercial

- Iceberg patrol/tracking in shipping lanes.
- Railway/pipeline/power line monitoring.
- Commercial fishing reconnaissance/sea-life monitoring.
- Environmental/pollution monitoring.
- Livestock monitoring.
- Mineral exploration.
- Weather sensing.
- Agriculture.

Additional advantages to the commercial airline industry:

- Less propellant means increased payload/passenger per aircraft.
- Global nonstop flights are possible.
- Increase in structural mass allows more electronics/passenger amenities.

RAMJET-ASSISTED MISSILE (RAM)

The BOMARC 440-kilometer (km)-range antiaircraft missile was developed by the U.S. Air Force in the 1950s to counter Soviet bombers. In the 1960s, the Talos, a long-range surface-to-air missile, was developed by the U.S. Navy and later converted to the Vandal missile. Both ramjets (Figure 8) activated at mach 1.

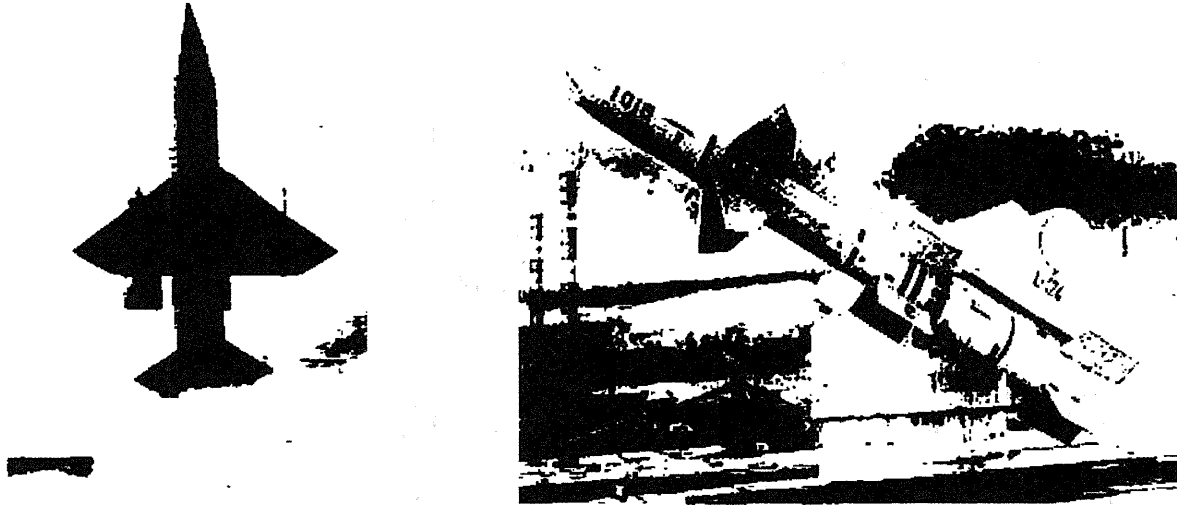

Figure 8. BOMARC (left) and Talos (right) Ramjet-Assisted Missiles (courtesy Boeing and the U.S. Navy)

The BOMARC range could be increased to 2,000 km with 1 milligram (mg) of positrons. In addition, positrons could act as ordnance to destroy electronics on missiles or aircraft by electromagnetic pulse (EMP) by detonation of micrograms of positrons up to hundreds of meters from the target.¹⁸

SINGLE-STAGE REUSABLE VEHICLE (SSRV)

The Department of Defense, NASA, and the aerospace industry are working to eliminate multistage rockets for access to low Earth orbit (LEO) to lower launch costs. An SSRV would integrate components and allow more rapid turnaround on missions.

The combustion SSRV has a lower payload ratio than conventional rockets. Current designs use combined-cycle or combination engines for the endoatmospheric phases of the mission. Use of air-breathing engines significantly reduces propellant mass and gross liftoff weight (GLOW). Improving payload mass requires reducing propellant and structural mass, both of which can be accomplished using positrons as fuel.

A PTRE eliminates propellant mass during the endoatmospheric phase of operation. Any reduction of propellant mass has serious positive effects for three reasons. First, it allows an increased payload/number of passengers per aircraft. Second, adding positrons on the milligram level does not change the lift requirements for the aircraft, resulting in longer range flights, perhaps exceeding 100 kilonautical miles (kNM). Third, the structural mass may be increased.

Tables 1 and 2 provide a mass budget comparison between a chemically fueled SSRV¹⁹ and a positron-powered SSRV.²⁰

Table 1. GLOW for Chemical SSRV²¹

<u>Vehicle Component</u>	<u>Mass</u>
Structure	25,700 kg
Thermal Protection	12,300 kg
Propulsion (4 engines)	14,900 kg
Electronics	<u>7,600 kg</u>
TOTAL DRY MASS	60,500 kg
15% Margin + Unused Propellants	11,400 kg
Payload	<u>11,340 kg</u> (24,948 lbs)
BURNOUT MASS	83,240 kg
TOTAL PROPELLANT	<u>368,300 kg</u>
GLOW	451,540 kg (993,388 lbs)

Table 2. GLOW for Positron SSRV²²

<u>Vehicle Component</u>	<u>Mass</u>
Structure	25,700 kg
Thermal Protection	12,300 kg
Propulsion (4 engines)	14,900 kg
Electronics	<u>7,600 kg</u>
TOTAL DRY MASS	60,500 kg
15% Margin + Unused Propellants	11,400 kg
Payload	<u>11,340 kg</u> (24,948 lbs)
BURNOUT MASS	83,240 kg
TOTAL PROPELLANT	<u>176,000 kg</u>
GLOW	259,240 kg (590,328 lbs)

The GLOW of the positron SSRV is 43 percent less than that of the chemical SSRV owing to reduced propellant mass. The PTRE will dramatically increase the affordability of space transportation by increasing the useful payload.

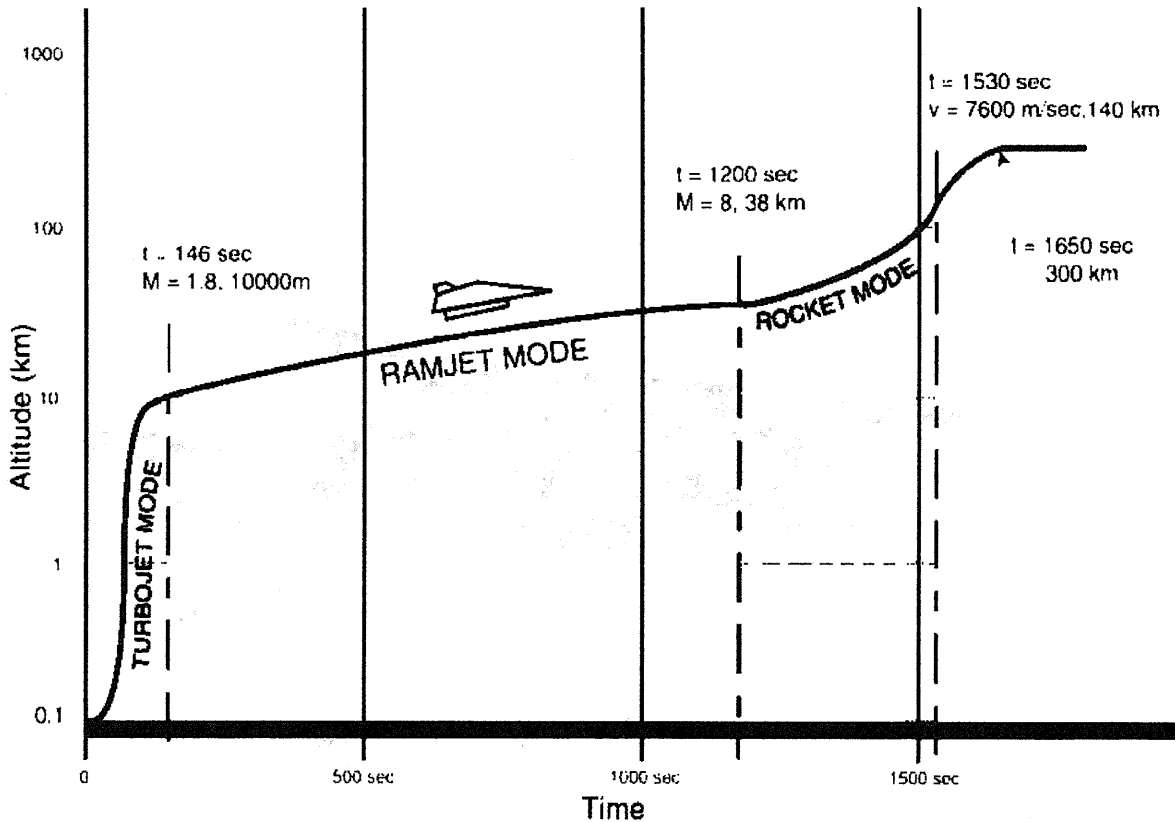

Figure 9. Positron SSRV Flight Profile (courtesy Positronics Research LLC)²³

The SSRV takes off horizontally (Figure 9) from Edwards Air Force Base, accelerates to mach 1.8 as a turbojet, and then goes to the ramjet mode. At mach 8 the rocket is ignited and takes the vehicle into LEO.²⁴ The positron mass budget for a 60,500-kg dry mass for ascension to LEO is 86.9 mg (Table 3).

Table 3. Total Positron Requirement for SSRV With a Dry Mass of 60,500 kg²⁵

<u>Mission Mode</u>	<u>Mass Of e[±]</u>
Turbojet – Launch	2.5 mg
Ramjet	76.5 mg
10% margin (turbojet mode upon landing, inclination changes, etc.)	<u>7.9 mg</u>
TOTAL	86.9 mg

An artist’s rendition of the SSRV is provided in Figure 10.

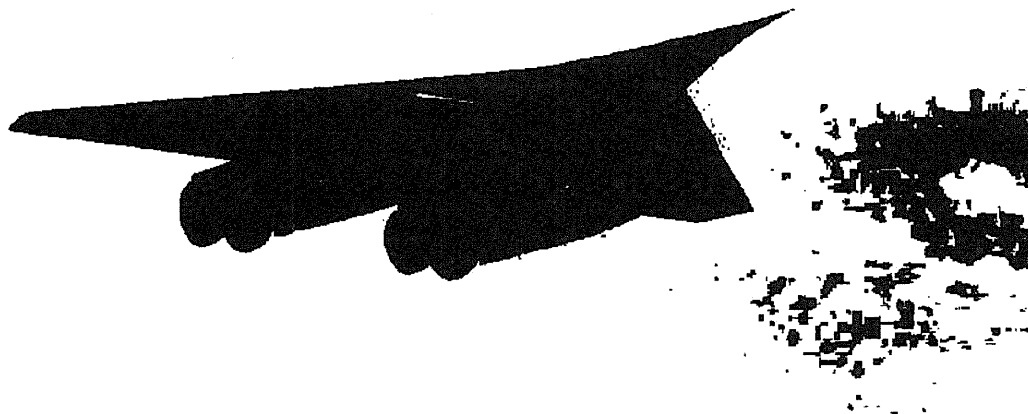

Figure 10. Artist's Rendition of a Four-Engine Positron SSRV (courtesy of Positronics Research LLC)²⁶

Positron-Powered Rockets

A positron rocket offers significant advantages over nuclear fission and antiproton rockets.²⁷ Nuclear fission reactors contain enormous amounts of highly toxic radioactive material, and antiproton rockets produce radioactivity in surrounding materials by interactions of high-energy mesons and gamma rays from antiproton annihilation. The proposed nuclear fission gas core rocket and antiproton adaptations would release radioactive fission fragments into the atmosphere. In contrast, positron rockets are totally radioactivity free.

Second, in the event of an accidental detonation of the positron fuel, the prompt (nanoseconds) burst of gamma rays can be shielded from humans on spacecraft. The $1/e$ absorption length of a 511-keV gamma ray in lead is 5.6 millimeters. A 13-centimeter (cm)-thick shield thus reduces the gamma ray flux by a factor 8.3×10^{-11} . To illustrate, a human behind such a shield at a distance of 10 meters from a 100-mg source of annihilating positrons would experience a whole-body radiation dose of 2 rem (roentgen equivalent man), which is within the annual tolerance for radiation workers in the United States.

The following sections investigate three positron rockets: solid core, gas core, and photon.²⁸ In a solid-core positron rocket, positrons heat a hydrogen working fluid through an attenuating solid such as tungsten. In a gas-core positron rocket, gamma rays directly heat propellant through a one- or two-fluid process. In a photon positron rocket, solid propellant is ablated from a surface bombarded by gamma rays.

THE SOLID-CORE POSITRON ROCKET

Figure 11 depicts a solid-core positron-powered rocket, similar in many regards to the NERVA nuclear-thermal concept.²⁹

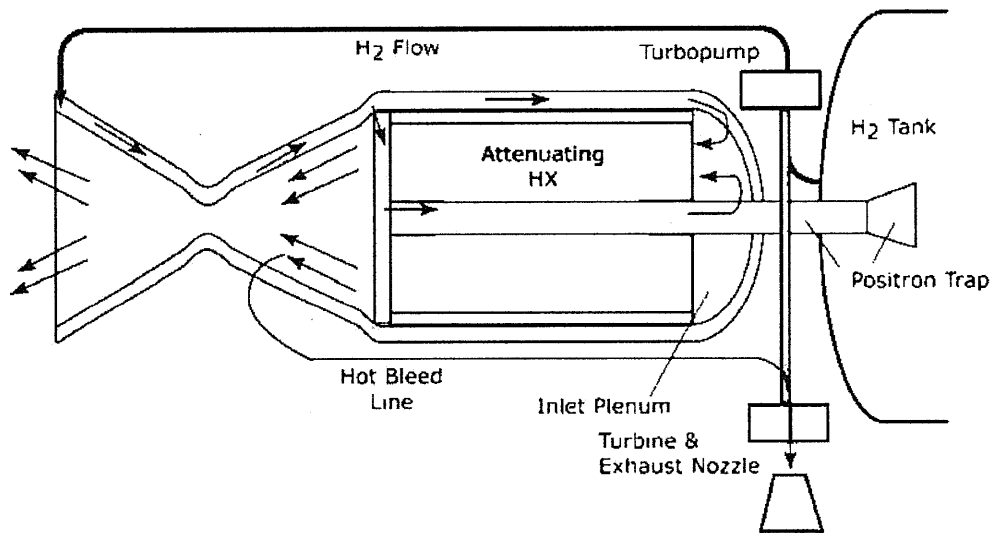

Figure 11. Solid-Core Positron Rocket Engine With a Hot-Bleed Configuration (courtesy Positronics Research LLC)³⁰

The cryogenic hydrogen propellant is supplied from a storage tank through a high-pressure pump and routed to cool the regenerative nozzle, the casing of the heat exchanger, and the central positron target tubes. Ps enters the inlet plenum to the attenuator that is heated by gamma rays to high temperature. Hydrogen propellant passes through the attenuating matrix and is heated and exhausted through a nozzle to generate thrust.

A small fraction of the hot exit propellant is bled off to a turbine that drives the high-pressure feed pump. The high-temperature bleed can either be mixed with cold hydrogen to reduce its temperature or directly fed to the turbine. If it is directly fed to the turbine, it must be made of materials that can withstand high temperatures. The bleed flow is exhausted from a turbine exit nozzle to space after driving the turbine.

As with the NERVA system, the positron solid-core concept is thermally limited by materials in the heating chamber. The difference is that the fission system requires a reactor and complex machinery, whereas the positron system relies on Ps atoms injected upstream from a storage unit. This has two advantages. First, a reduction in the engine mass for a given thrust is realized; second, there is greater choice in materials to be used in the heating chamber.

A thermal-fluids analysis was conducted to predict performance. A specific impulse of 920 seconds is attainable with chamber temperatures at 3,000 Kelvin. The corresponding thrust and power emulate fission systems. Mars trip burn times are on

the order of 30 minutes, indicating that a spacecraft employing three 72-kN solid-core engines would require 6-9 mg of positrons per mission.

Solid-core fission and positron systems are compared in Table 4.

Table 4. Comparison of Space Propulsion and Power Systems – Solid Core

	Fission-Based	Positron Powered
Technology	<ul style="list-style-type: none"> • NERVA/Rover demonstrated • Never flight tested 	<ul style="list-style-type: none"> • Conceptual • Must demonstrate positron storage and controlled injection • Near-term technology demonstration for positron storage needed
Performance	<ul style="list-style-type: none"> • $I_{sp} \approx 950$ sec • Thrust $\approx 72 - 123$ kN • Power $\approx 367 - 5320$ MW (matched to thrust) • Lifetime ≈ 2 hours total operation 	<ul style="list-style-type: none"> • I_{sp} - as in fission systems • Thrust -variable, similar to fission systems • Power - matched to thrust • Lifetime - set by material considerations
Operation	<ul style="list-style-type: none"> • Design dictated by neutronics, fuel burn up and fission poisoning • High neutron & gamma radiation during operation • Requires active, accurate and massive control • Requires shutdown cooling to remove heat from nuclear waste • Radiation after shutdown due to fission products 	<ul style="list-style-type: none"> • No criticality, burn up or poison accumulation issues • Design based only upon heat transfer and gamma attenuation issues • Does not require shutdown cooling • Simple on-off control, power controlled by rate of positron utilization
Materials	<ul style="list-style-type: none"> • Material dictated by neutronics • Propellant-heated H_2 • Working fluids for power systems - inert gas • Uranium in graphite media • Corrosion issues require complex fuel 	<ul style="list-style-type: none"> • Not a radiation source • Material choices dictated by temperature • Propellant-heated H_2 • Working fluids for power systems - inert gas
Payload Integration	<ul style="list-style-type: none"> • Requires massive shield from reactor • Requires separation from reactor • Complex design issues due to neutron scattering 	<ul style="list-style-type: none"> • Shield required around manned area separated from positron storage • Propulsion and power sources can be integrated into vehicle
Post Operation	<ul style="list-style-type: none"> • Not able to return to earth or inhabited surface • Not reusable or refuelable 	<ul style="list-style-type: none"> • Able to return to Earth or inhabited surface • Reusable and refuelable

THE GAS-CORE POSITRON ROCKET

The gas-core positron concept follows nuclear gas-core concepts,^{31, 32, 33} which are different from the solid-core concept in that gamma rays directly heat a fluid under pressure. The limit of the solid-core approach is melting temperatures of the solid matrix gamma ray attenuator. By direct heating, temperatures can increase significantly as long as the gas does not appreciably heat the walls.

Four versions of the gas-core concept are illustrated in Figure 12. Synchronous with pulsed Ps injection are (a-c) pulses of LN₂ or LNe or LH₂ with LXe gamma ray attenuator and (d) pulses of LH₂ where Ps is encapsulated in lead, a gamma ray converter. For fluid injection, a turbo-pump (not shown) is located upstream, with power obtained from a positron Brayton cycle system described later in this paper.

Results from computational fluid dynamics codes reveal that high-density regions of the fluid move away from the gamma ray source when the power in the system exceeds 300 megawatts. Under these conditions, the propellant does not efficiently absorb gamma rays. Furthermore, calculations of heat required for continuous operation suggest the vortex configuration of (b) breaks down and reverts to two-fluid flow.

However, both the two-fluid, flow-through model and the Ps lead-cartridge concepts show promise if the mass flow rate of the hydrogen propellant exceeds that of the xenon or lead by a factor of five. By operating in a pulsed mode, one should be able to control the positron delivery into the chamber core. With complete absorption of gamma rays in the 2-cm lead casing, performance of the system matches that of previously examined systems.^{34, 35}

Thrusts of 130 kN (1,000 atmospheres) are predicted for a single-engine system with an efficiency of 85 percent. Burn times are 30 minutes for $\Delta V = 3.7$ km/second (sec) with 25 mg of positrons consumed for a 50,000-kg burnout mass. The limit of the gas-core concept occurs near the thresholds for ionization of hydrogen, corresponding to I_{sp} of $\sim 2,500$ sec.

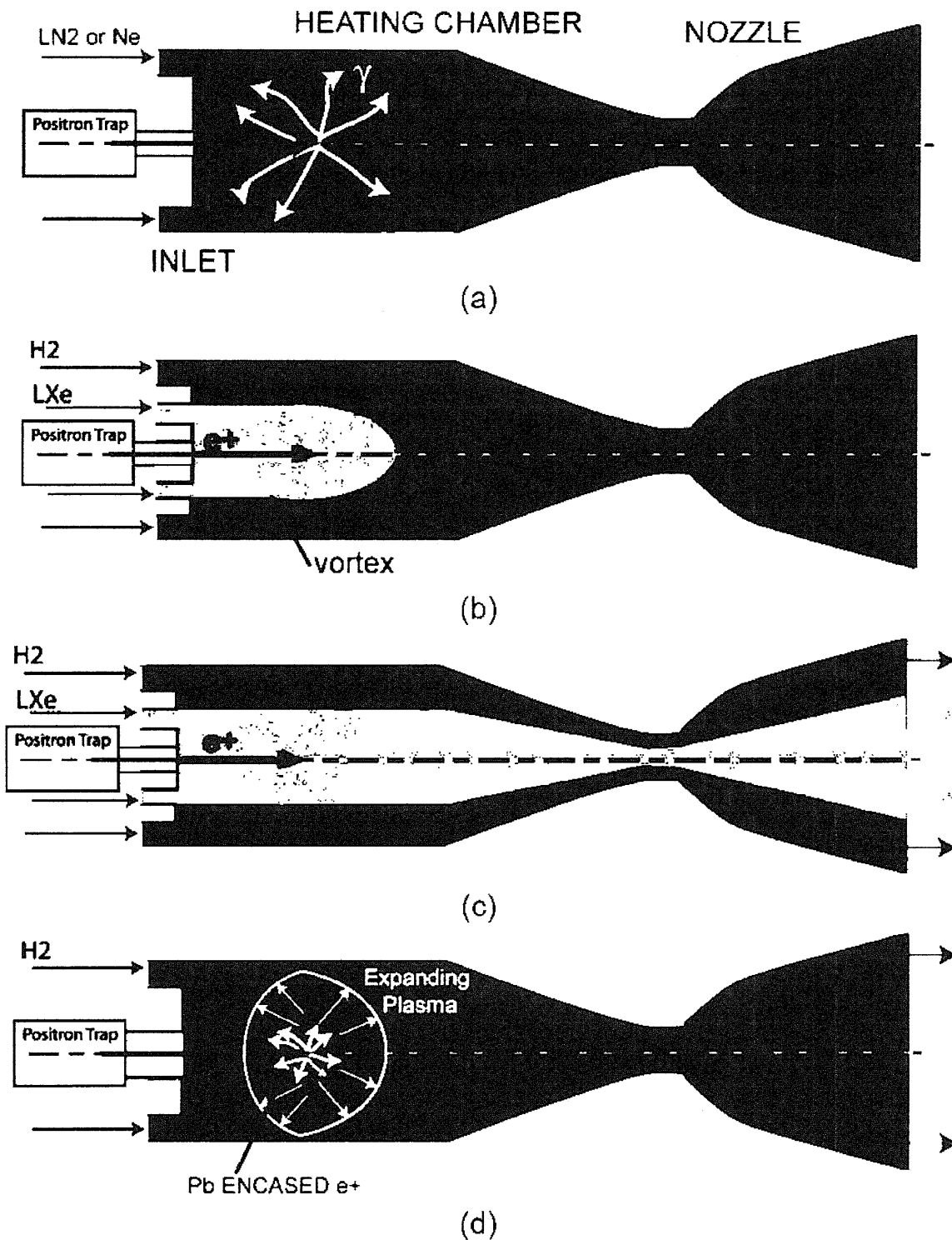

Figure 12. Fluid Systems. (a) One-fluid system of LN₂ or Ne propellant; (b) Two-fluid system of LH₂ and LXe; (c) Two-fluid flow-through system with LH₂ at higher mass flow rates than LXe; and (d) One-fluid LH₂ system with lead encapsulated Ps (courtesy Positronics Research LLC)³⁶

THE SÄNGER PHOTON POSITRON ROCKET

In 1953, German engineer Eugen Sänger proposed the photon rocket. One means of providing thrust was to shower a parabolic mirror with positron annihilation gamma rays.³⁷ Unfortunately, there are no materials that reflect gamma rays at large angles.

A schematic of a modified Sänger photon rocket is shown in Figure 13. Ps is emitted in 'pellets' from several storage banks located behind the engine. Positrons are programmed by supporting fields to annihilate in front of a stiffened pressure plate, the shape of which was assumed to be parabolic for this work.³⁸

To make the Sänger photon rocket practical, solid propellant that can be ablated from the plate is added. Gamma rays deposit energy on the surface of the ablation material and jettison high-energy particles with large I_{sp} . As the solid material recedes from the target, the location of the positron annihilation can be correspondingly moved inward to preserve focal properties of the system. A thickness of a few meters of material is sufficient for a planetary mission.

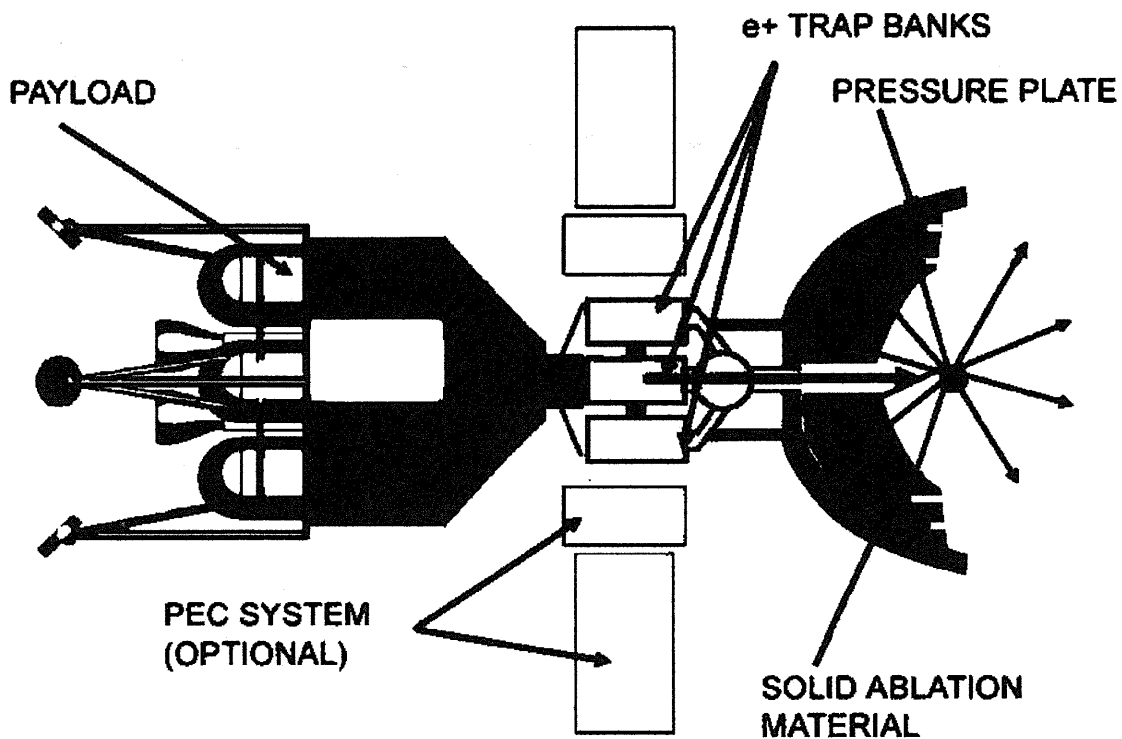

Figure 13. Modified Sänger Photon Rocket Concept (courtesy Positronics Research LLC)³⁹

The predicted I_{sp} for this system results in fast transit times to Mars, warranting a positron power plant. Unlike the solid-core or gas-core concepts, there are no means to draw off some of the ablated material to provide power. A separate Brayton-cycle positron energy conversion system provides power to the pellet mass driver and other

components. Alternatively, solar collectors or closed-loop nuclear reactors could be employed.

To improve ablation efficiency, annihilation gamma rays must be wavelength shifted (WLS) by passing them through a high-Z WLS material. The material of choice, lead, also serves as the shell of the Ps pellet. The pellet vaporizes into high-energy plasma, and the WLS photons propagate to the pressure plate. Silicon carbide ablation material has been adopted from the antiproton catalyzed microfission/fusion concept^{40, 41} developed at Penn State University by the author and coworkers. Photon energy distributions are shifted through 2 cm of lead to 1-10 keV from 511 keV with 85 percent efficiency.

Performance depends primarily on the energy of the WLS photons and the energy per pellet. At 8 keV, I_{sp} is in the range 1,200-3,000 sec. Thrust is 40-145 kN, the latter at a pellet injection rate of 1 hertz. The total quantity of positrons consumed for a one-way trip to Mars over this range of I_{sp} is 15-40 mg with 50 percent of gamma rays striking the plate and a 85 percent WLS efficiency.

POSITRON ROCKET SYSTEM COMPARISON

A side-by-side comparison of three positron rocket propulsion concepts is presented in Table 5 for a one-way transit to Mars using $\Delta V = 3.7$ km/sec.

Table 5. Comparison of Three Positron Propulsion Concepts for Mars Mission

	Solid-Core	Gas-Core	Sänger Ablation
I_{sp}	650 - 920 sec	1000 - 2500 sec	1200 - 3000 sec
Thrust	72 kN, small class	130 kN (1000 atm)	40 -145 kN (1 Hz)
Limits	<ul style="list-style-type: none"> Wall and nozzle temperature 	<ul style="list-style-type: none"> Wall and nozzle temperature H Ionization 	<ul style="list-style-type: none"> Positron density per pellet
e+ mass	<ul style="list-style-type: none"> 8-9 mg (100% efficiency) 	<ul style="list-style-type: none"> < 25 mg (85% efficiency) 	<ul style="list-style-type: none"> 15 - 40 mg (42.5% efficiency)
Special Notes	<ul style="list-style-type: none"> Continuous burn Multiple engines may be possible Hot-bleed line possible 	<ul style="list-style-type: none"> Pulsed burn Multiple engines may be possible Hot-bleed line possible Engine can be throttled 	<ul style="list-style-type: none"> Pulsed burn Multiple engines may be possible No direct onboard power Engine can be throttled
Future work	<ul style="list-style-type: none"> Efficiency study 	<ul style="list-style-type: none"> Efficiency study Lower pressure possible? 	<ul style="list-style-type: none"> Further WLS and radiation transport study

POSITRON ENERGY CONVERSION FOR ONBOARD POWER

Research was conducted on positron utilization in a standalone, closed-loop, high-power system.⁴² A Brayton cycle engine (Figure 14) was investigated with output power of 100 kW, consistent with Mars Reference Mission specifications.^{43, 44} Results show efficiencies of 25-30 percent and positron consumption of 7 $\mu\text{g}/\text{hour}$.

Such a power system would have practical meaning for fast transits to Mars where positron consumption does not dominate rocket positron consumption.

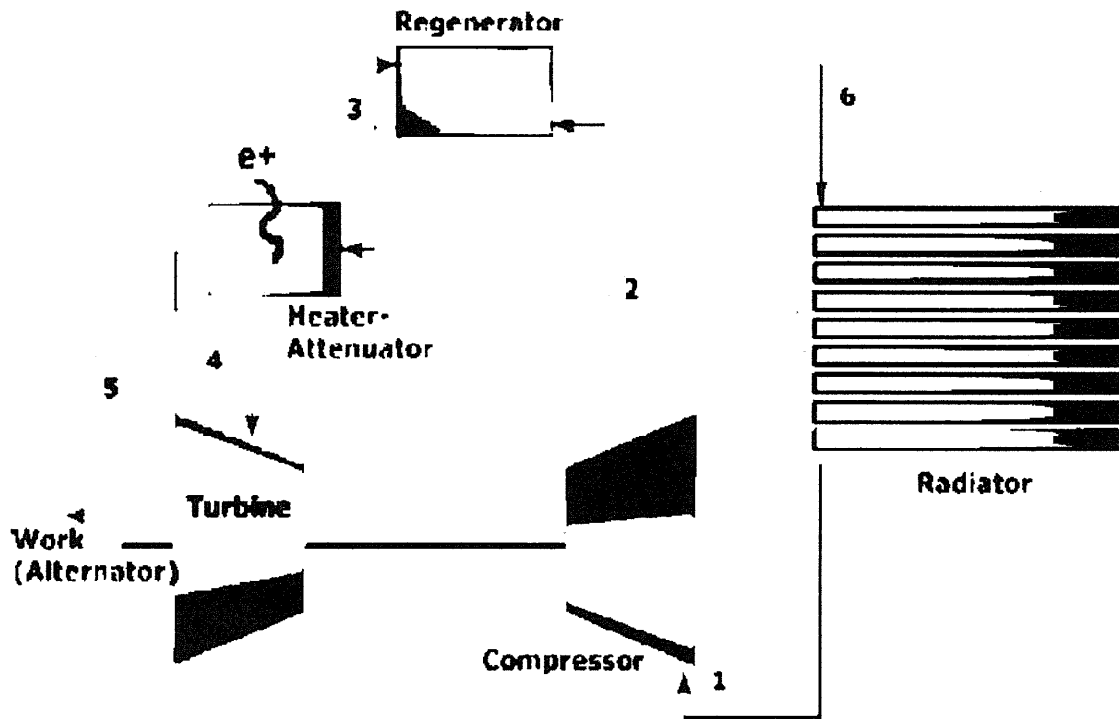

Figure 14. Closed Brayton Cycle Using Positron Annihilation (courtesy Positronics Research LLC)⁴⁵

In addition, a small, 110-watt, positron-driven generator (Figure 15) for small, onboard tasks was designed around the NASA Glenn Research Center Stirling Radioisotope Generator,⁴⁶ with heat provided by Ps gamma rays.

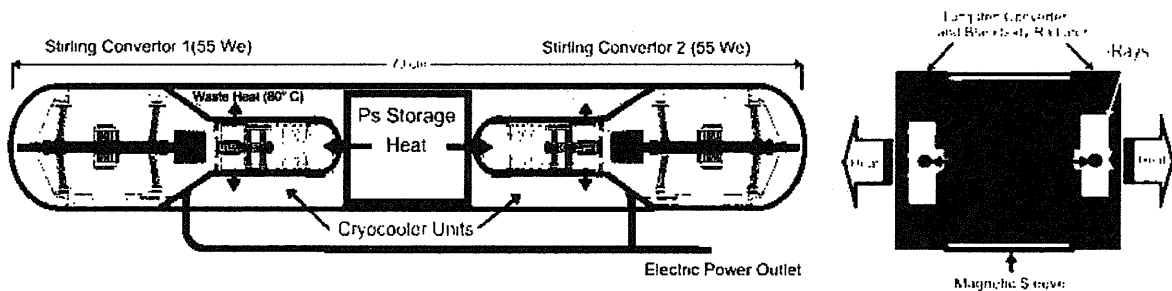

Figure 15. Conceptual 110-Watt Positron Closed-Cycle Generator Based on the NASA Glenn Research Center Stirling Radioisotope Generator⁴⁷ (courtesy Positronics Research LLC)⁴⁸

Positrons for a Manned Mars Mission

Positron propulsion systems improve engine performance, making them an attractive substitute for chemical and nuclear systems for manned exploration of the planets. One of the boldest challenges is a manned mission to Mars. Onboard propellant requires an overall interplanetary system mass that prohibits use of any type of existing launch vehicle, including the Saturn V. The need to protect astronauts from radiation hazards in space inhibits use of low-impulse interplanetary trajectories to reduce propellant mass. Missions must be established that can transport astronauts to Mars in less than 180 days.

Demands on a positron engine to get from LEO to Mars are based on two parameters: mass of the spacecraft after burnout and the ΔV provided by orbital mechanics. Efforts to minimize burnout mass for a positron-based rocket spacecraft prompted examination of previously designed systems. The NASA Mars Exploration Study Team studied such systems in 1997-98.^{49, 50}

Conclusions reached by NASA and adopted for this study include:

- To make the Mars mission economically feasible, multiple payloads should be launched to Mars instead of a single, "all-in-one" vehicle. This keeps payload masses within reach of existing chemical launch systems.
- A solid-core nuclear-thermal rocket (NTR) was studied. The study adopted existing NERVA rockets with $I_{sp} = 900$ seconds and a core temperature near 2,800 °C. The 1993 study examined 15 kilopound-force klbf and 20 klbf rockets.⁵¹
- Each launch had a payload consisting of the NTR with its Mars payload.
- Unpiloted cargo was sent on a low-energy ("C3") Hohmann-type transfer, generally the slowest means of reaching Mars.
- The Mars excursion vehicle should be sent on a "fast transit" to Mars from LEO. A fast, 180-day mission would not require artificial gravity on the spacecraft to protect astronauts from weightlessness.
- The Earth return vehicle (ERV) sits in Mars orbit at 250-km periapsis and waits until astronauts have docked from Mars using a liquid oxygen (LOX)/methane propulsion system. The ERV uses a chemical propulsion system to return home to avoid use of a fission-based propulsion plant in the atmosphere.
- Minimization of ΔV to Mars is performed by launching during estimated planetary conjunctions (every 778 days) and by using aerobraking.
- Aerobraking uses the chemical propulsion system of the cargo vessel or lander. Payload is jettisoned from the NTR system (called the trans-Mars insertion system [TMI]) sometime during the trip to Mars.
- To reduce the probability of impact with Earth, an additional ΔV is given to the TMI stage after the payload has separated.

Benefits of using positrons for a Mars mission include:

- The "disposable ΔV " used to propel TMI stages into low-probability Earth or Mars intercepts can be eliminated, reducing total propellant mass.
- Reduction in shielding and engine mass give lower initial mass low Earth orbit for launch vehicles or faster transits for piloted missions.
- The ERV uses a positron engine instead of LOX/CH₄. This gives significant mass savings or an equivalent reduction in Mars-to-Earth return time for astronauts.
- The improvement in I_{sp} translates to either a reduced launch payload mass for cargo missions or reduced transit times for piloted missions to Mars.
- More chemical propellant can be stored on the lander to improve aerobraking or landing strategies that reduce hazards for astronauts.

Launch dates are set for around 2030. Assuming minimum ΔV for Mars opposition-class missions, interplanetary scenarios are illustrated in Figure 16. The ΔV for an insertion trajectory into Mars for the manned mission (Figure 16b) is $\Delta V = 3.7$ km/sec. Each manned trajectory assumes a 180-day transit time.

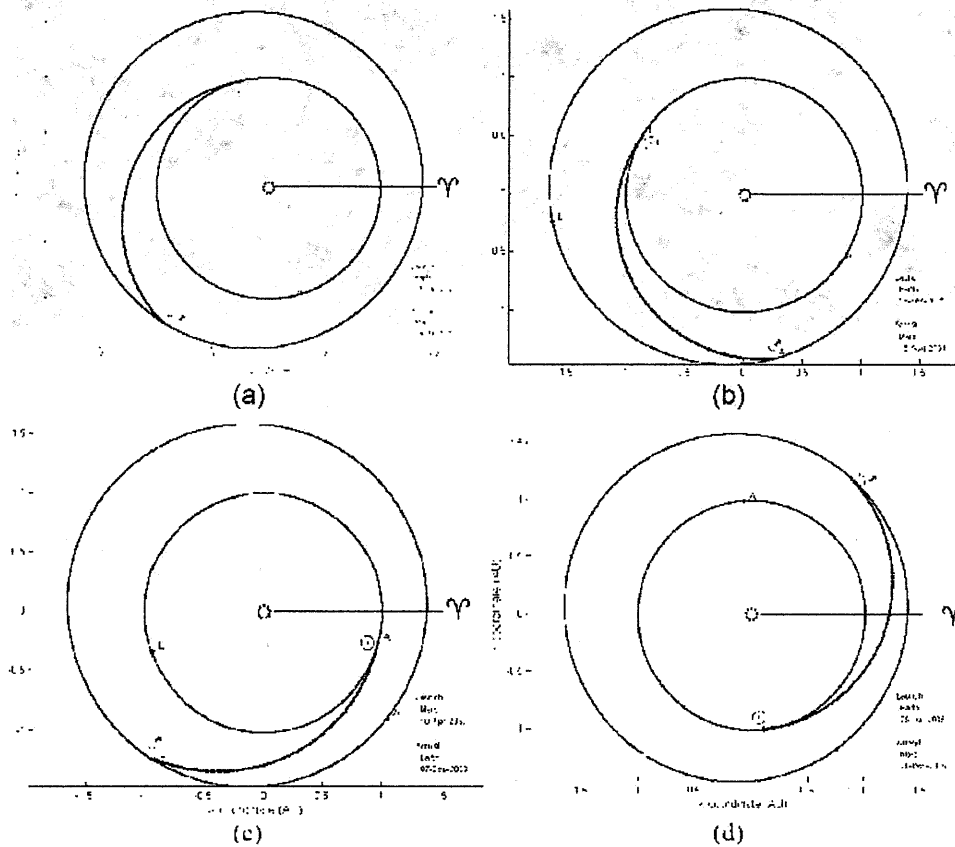

Figures 16. Mars Trajectories (X-coordinates defined in direction of Aries): (a) 2029 cargo mission; (b) 2031 manned lander to Mars; (c) 2033 manned return to Earth; (d) 2035 manned lander to Mars, if necessary (courtesy Positronics Research LLC)⁵²

The Mars reference mission^{53, 54} considered payload masses of 60,000 kg for 2015 missions. This can be reduced to 45,000 kg assuming technological advances by 2031 with a complete interplanetary spacecraft mass of 90,000 kg.

In summary, the mission scenario for a positron spacecraft is similar to that for existing studies, but with the use of less costly launch vehicles. Every 778 days, two 45,000-kg payloads are launched from Earth using a Saturn V or equivalent chemical rocket. One payload is the unmanned system or manned crew lander sent to Mars; the other contains the positron propulsion system and the propellant tank. They are assembled as a complete unit in LEO.

Unmanned systems are launched in advance of the crewed system in order to ensure that the Martian habitat is well established. The crew arrives at Mars in late 2033, performs research for 1 year, and then returns home in a smaller positron spacecraft using a shorter trajectory. Artists' renditions of two possible positron spaceships previously described in this study are shown in Figure 17.

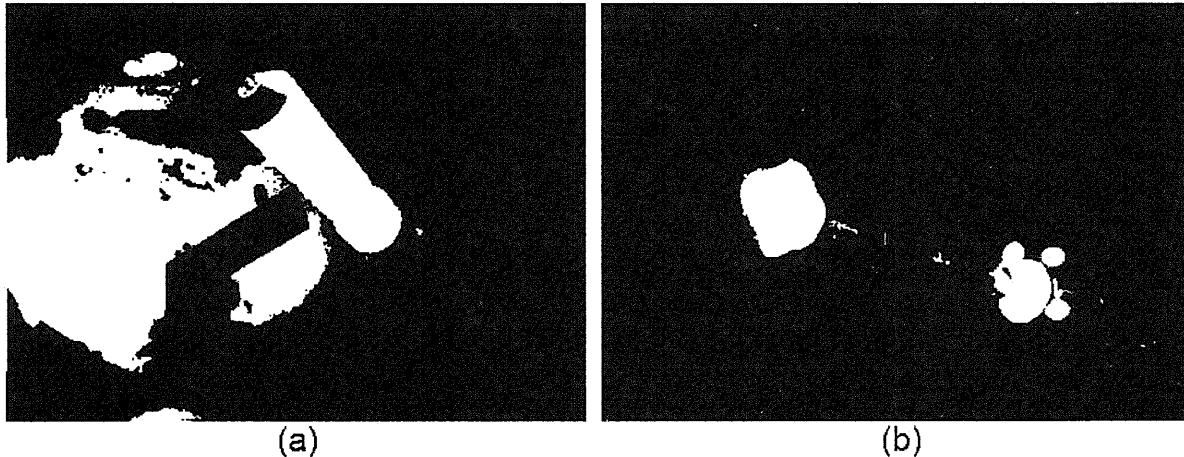

Figure 17. Spacecraft Using Positron Engines. (a) Solid-core system enters Mars orbit; (b) Modified Sängner photon rocket system burns for landing on Mars (courtesy Positronics Research LLC).⁵⁵

Architectures for Mars exploration using a positron SSRV are summarized below:

- Before humans leave for Mars on initial flights, cargo ships precede them to Mars on low-energy trajectories to take the components of a Mars space station (MSS) and necessary supplies, including a Mars surface lander (MSL). The MSS will be similar to an Earth space station (ESS). The cargo ships will utilize positron rocket engines.
- Manned positron SSRVs launched from Earth rendezvous in LEO with the ESS. The SSRV is a horizontal-takeoff, horizontal-landing winged-body, manned vehicle in which the first stages of flight use air-breathing engines with positrons heating the air. It switches to the rocket engine to complete the final ascent phase to LEO.
- Once ready for interplanetary flights at the ESS, including refueling, the SSRV flies to Mars on a fast, high-energy trajectory, carrying a crew of five or six astronauts and powered by positron rocket engines. The SSRV conducts a rendezvous with the

MSS, and the astronauts descend to the Mars surface on the MSL using a high-thrust variant of the positron rocket engine.

Positron Production

Positrons are currently produced at particle accelerators worldwide for basic and applications research. For example, the positron-emitting radioisotope Na^{22} (2.7 year mean lifetime) is made by bombarding targets with neutrons from a high-energy proton accelerator in the reaction $\text{Al}^{27}(n,x)\text{Na}^{22}$. Capture of these positrons is used to form beams with keV (slow) to MeV (fast) energies. Handling of large radioactive sources results in limits of 10^6 slow positrons/sec.

For intensities up to 10^{10} /sec, bombardment of metal targets with electron beams in the 10- to 100-MeV range is used, followed by collection and acceleration (deceleration) of positrons to form fast or slow beams. In addition, it has recently been shown that slow positron beams of up to 10^{11} /sec can be realized by converting neutrons in reactors to electron-positron pairs in thin metal foils.

Much higher positron currents are being sought in a variety of proposed solutions. Illustrated below are a few of the more promising concepts.

First, in 1996, the U.S. Naval Research Laboratory⁵⁶ proposed developing an intense source of fast positrons (10^{16} /sec) utilizing compact electron betatron accelerators.

Second, tabletop femtosecond laser-driven positron sources currently under development at the National Ignition Facility (Lawrence Livermore National Laboratory), the Rutherford-Appleton Laboratory (United Kingdom), and the Max Planck Institute (Munich) look promising, although more must be done to demonstrate efficient collection of positrons into beams.

Finally, a most important step forward is multi-gigaelectronvolt (GeV) energy electron storage rings being developed for the high-energy physics International Linear Collider (ILC) project that uses undulators in electron beams to create intense photon beams that produce intense (10^{14-16} /sec) positron beams by pair production.⁵⁷ A schematic drawing from one proposal for the ILC is shown in Figure 18.⁵⁸

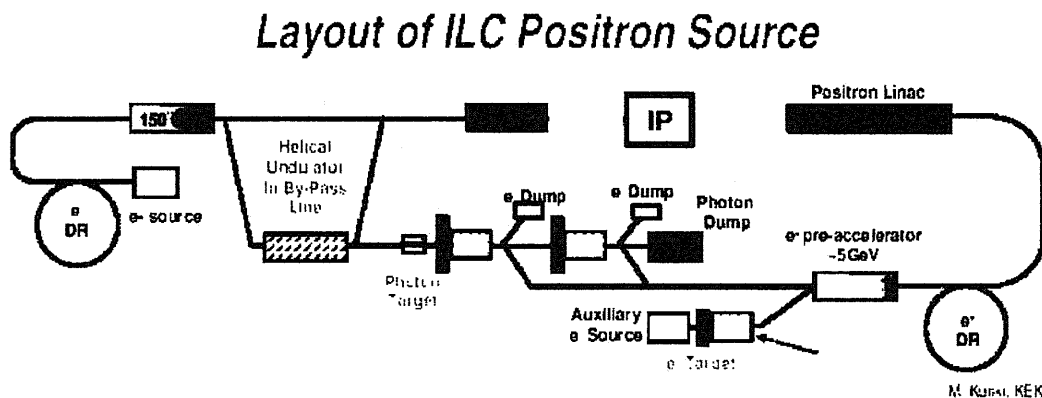

Figure 18. Proposed Undulator-Based Positron Source for the International Linear Collider (courtesy KEK, Japan)⁵⁹

Assuming that 10^{16} positrons/sec can be realized in the next 10 years, then 150 micrograms could be produced in 6 months to enable a globe-encircling flight of a small air-breathing turbojet UAV as discussed earlier.

Positron Costs

An independent study has been done to determine future costs of positrons and, for comparison, antiprotons as well. The results, shown in Table 6, are based on data for existing sources and proposals for future sources.^{60, 61, 62}

Table 6. Positron and Antiproton Expected Costs in the Next 10 Years

Source	Trap Injection Energy (MeV)	Filling Rate (sec ⁻¹)	When	\$/JOULE (annihilation)
CERN AD (pbar) ²⁵	0.01 – 0.1	4×10^5	Now	?
Fermilab (pbar) ²⁶	<0.002	2.8×10^4	Now	333*
e ⁺ /14 MeV e ⁻ linac ²⁷ /ILC ²⁴	0.1	$5 \times 10^{12}/10^{16}$	2011/19	0.4/0.004**

* \$100 million/year (est. op. cost).

** \$5 million/year (est. op. cost, adjusted for inflation)/\$100 million/year (est. op. cost).

Two clear results of the study should be noted.

First, measured on a scale of dollars per joule of annihilation energy, positrons cost less than antiprotons by a factor of 1,000-100,000. Because each antiproton produces 1,836 times more energy per annihilation than a positron, this result appears to defy logic. However, the laboratory energy threshold for producing antiprotons is 6,000 times greater than for positrons, requiring a relatively complex proton synchrotron that is costly to construct and run. In addition, antiprotons are made at much higher laboratory energy than positrons and require costly apparatuses to decelerate them to trapping energies.

On the other hand, because electrons and positrons are relativistic at very low energy, their electron production and secondary systems are comparatively simple and less costly to operate and maintain than proton systems. These factors, combined with the absence of radioactive residue associated with positron annihilation, make positrons the obvious choice over antiprotons.

Second, the cost of positrons is projected to be $\$0.004/\text{J} \times 180 \text{ MJ}/\mu\text{g} = \$720\text{K}/\mu\text{g}$. Hence, the cost of 1 gram is $\$0.72\text{T}$, or 5 percent of the 2008 U.S. gross domestic product (GDP). A 2000 NASA study⁶³ on which this author collaborated placed the cost of antiprotons at $\$64\text{T}/\text{g}$, consistent with the $\$333/\text{J}$ figure in the second line of Table 5, and roughly six times the 2000 GDP. Unfortunately, this is still being quoted in U.S. scientific and government communities. The dramatic reduction in the unit cost of antimatter since 2000 is due to a new emphasis on positrons by the physics community, and hopefully this paper will help spread that good news.

Earlier, a nonstop flight around the globe by a small positron UAV was described as equivalent to the 1927 Spirit of St. Louis transatlantic flight of Charles Lindbergh. From

Table 5, the required 150 µg for this epic flight could be manufactured in 6 months for \$96 million, or 0.0007 percent of U.S. GDP.

Positron Storage

Confinement of antimatter has been reviewed extensively in the literature.⁶⁴ Historically, the first approach was the Penning trap.⁶⁵ Stores of 10^9 positrons for 1 hour have been achieved.⁶⁶ Electric potentials are required to overcome space charge forces.⁶⁷ To illustrate, confinement of 10^{15} positrons in a 10-cm-radius sphere in a perfect vacuum requires an electric potential of 240 kilovolts. Laboratory control of such large potentials restricts stores to < 1 picogram (10^{15}).

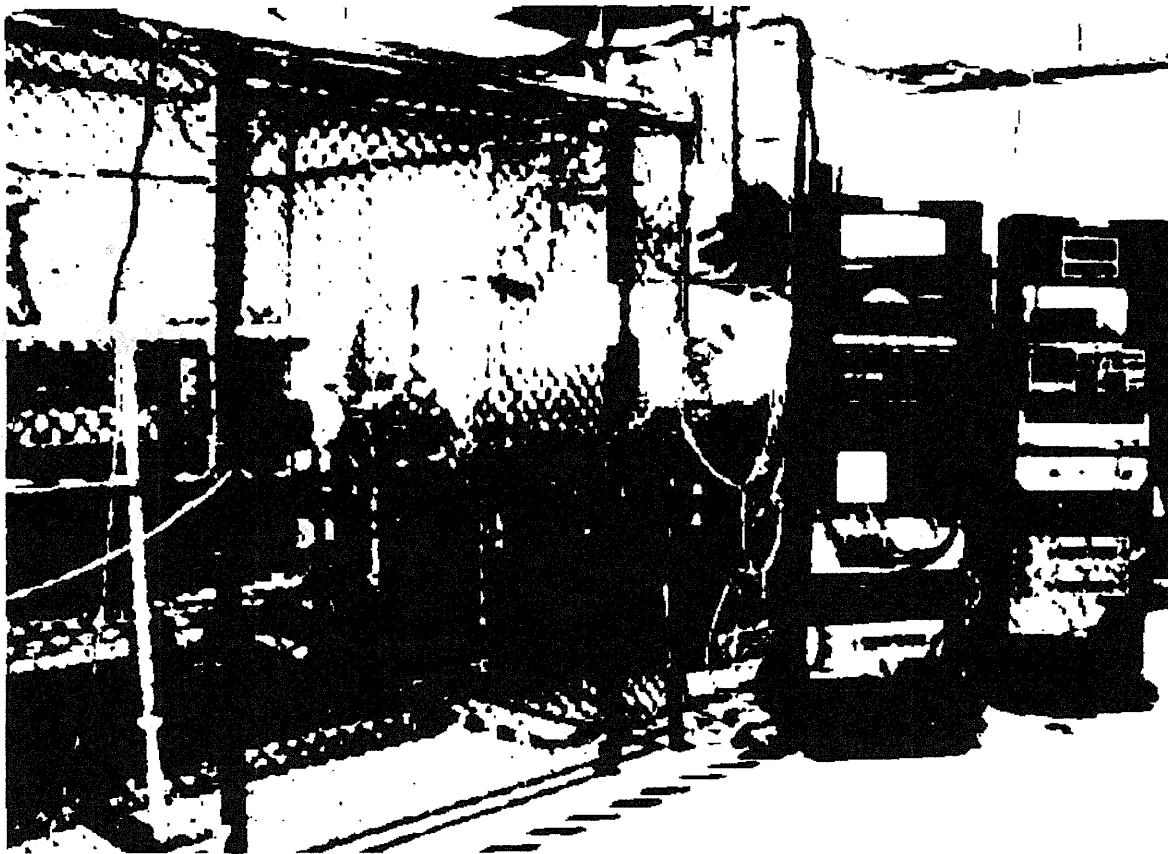

Figure 19. Penning Trap With Trapping Volume of 1,000 Cubic Centimeters (center), Injection Apparatus (left) and Controls (right) (courtesy Positronics Research LLC)⁶⁸

In addition, with a magnetic field there are magnetic energy density restrictions on confinement of positron plasmas. The Brillouin Density Limit is:

$$n_B = \epsilon_0 B^2 / 2m_e \quad (1)$$

For a practical magnetic field of 1 Tesla, $n_B = 9.7 \times 10^{12}$ /cubic centimeters. In a 10-cm radius sphere, the Brillouin Number Limit is 4×10^{16} (40 picograms). Therefore, by

either space charge or magnetic energy considerations, the storage limit is tens of picograms, 7-8 orders of magnitude short of 100 micrograms, where practical uses of positrons begin to emerge, as illustrated earlier.

The second approach is confinement of neutral Ps atoms in manufactured porous media of either regular lattices of atoms, such as polymers, or irregular strands of insulator material encapsulating voids, such as silica aerogel.^{69, 70} Regardless of void size, Ps atoms ultimately annihilate with electrons attached to atoms on the boundaries of voids by the so-called "pickoff" process. Therefore, large, observable lifetimes require materials with extraordinarily large voids.

FORMATION OF POSITRONIUM IN POROUS MEDIA

Positrons are injected into a porous material at low energy (~ 100 keV) to ensure that they stop and form a Ps atom over a distance of a few millimeters.⁷¹ The positron rapidly loses its energy by collisions with electrons attached to atoms in the material. As it nears 6.8 electronvolts (eV)—the binding energy of the ground state of Ps—it captures a weakly bound electron and forms Ps. It diffuses through the material, and over about 1 nanosecond, its energy is rendered to the room temperature of the material, 0.025 eV. This is called thermalization.

The quantum mechanical model of Ps is remarkably similar to the hydrogen atom. The major difference is that Ps spontaneously annihilates, whereas hydrogen is stable. The "self-annihilation" of Ps due to overlap of electron and positron wave functions results in extremely short lifetimes, as noted earlier.

Lifetimes against "self-annihilation" can be demonstrably increased if the following two conditions are met: (1) a way is found to isolate the electron wave function from the positron wave function, and (2) materials provide voids large enough to allow detection of lifetimes well beyond 142 nanoseconds (ns). A high vacuum is required to avoid Ps annihilation on gas molecules within the voids. The following describes how Positronics Research LLC has approached these issues in the laboratory.⁷²

LONG-TERM STORAGE OF POSITRONIUM

Under crossed magnetic and electric fields, Ps assumes a doubly oblate shape (Figure 21), with the electron and positron separated by hundreds of nanometers to tens of micrometers, depending on the size of the fields.⁷³ Computation of lifetimes against quantum mechanical barrier penetration reveals lifetimes in excess of 1 year over a large range of magnetic and electric fields.

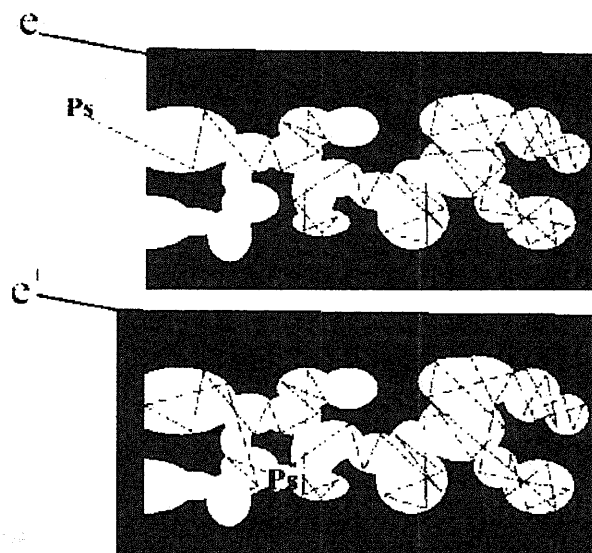

Figure 20. A Positron Forms Ps on the Edge of a Void, Thermalizes, and Becomes Trapped in a Void Before Annihilating (courtesy University of Michigan)

Lifetime shortening owing to cyclotron radiation of the electron and positron gyrating in the magnetic field are not included in this model. Because this process is proportional to B^2 , magnetic fields should be small—less than 0.1 Tesla based on our computations of the effect. This, in turn, renders the atom very large, with up to 1-micrometer elongation. If this can be verified in the laboratory, the first of the two conditions laid out in the previous section will be satisfied.

Next, it is important to identify a storage medium with the largest possible voids. Silica aerogel is a promising material that was developed by NASA because of its extremely low density and excellent thermal insulating properties. It is composed of strands of SiO_2 (silica) grains suspended in a gel that has been dried and expanded by injection of gases to a very-low-density configuration of large voids within an irregular lattice of silica strands (Figure 22). Silica aerogel is available commercially with typically 20-nanometer average voids. Recent research has produced silica aerogel with up to 1-micrometer void sizes.

Experiments in Japan and at Positronics Research LLC³³ with low-energy positrons in silica aerogel show a high efficiency (~35 percent) for making Ps through the interaction of the positron with silica grains. High radiation exposure from positrons implanted in the material result in it becoming "paramagnetic," permanently at low temperatures, with a high density of "dangling bonds" containing very loosely bound electrons that explains the high efficiency for Ps formation. It therefore serves a dual role as source and storage medium for Ps. What lifetimes might be expected working with this material?

The Ps decay rate in a porous material is given by:⁷⁵

$$\lambda = k'/(R - r') + \lambda_T + \lambda_q \tag{2}$$

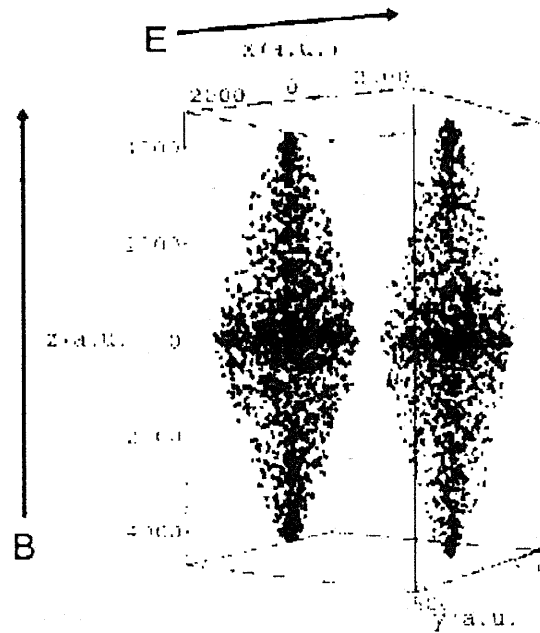

Figure 21. Computer Simulation of Ps Atoms in a 5-Tesla Magnetic Field and 100 V/cm Electric Field (1 a.u. = 0.052 nm) (courtesy University of Bielefeld, Germany)⁷⁴

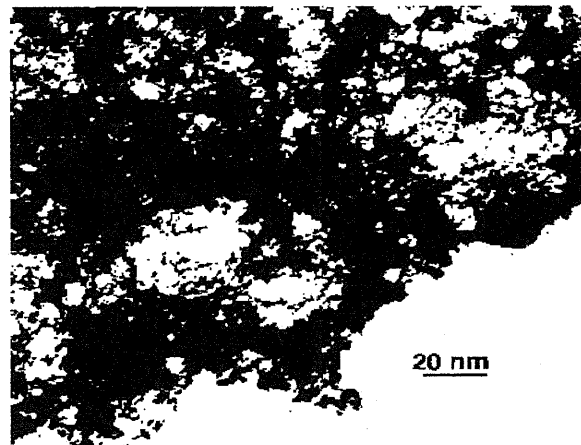

Figure 22. TEM of Silica Aerogel (courtesy Lawrence Berkeley Laboratory)

where k' is characteristic of the electron density for silica strands = $0.0164 \text{ nm}\cdot\text{ns}^{-1}$, R is the void radius (nm), r' is the silica strand thickness (0.68 nm), λ_{τ} is the self-annihilation rate, and λ_q is the quenching rate for air (0.00427 ns^{-1} at 0.1 torr vacuum, typical of a standard rotary pump). To illustrate, without magnetic and electric fields ($\lambda_{\tau} = 1/142 \text{ ns} = 0.007 \text{ ns}^{-1}$) and for $R = 20 \text{ nm}$, $\lambda = 0.0121 \text{ ns}^{-1}$, or $\tau = \lambda^{-1} = 82.5 \text{ ns}$. This is consistent with our measurements.⁷⁶

Assuming self-annihilation is suppressed ($\lambda_{\tau} \sim 0$) by crossed magnetic and electric fields, a high vacuum (10^{-5} torr) is maintained ($\lambda_q \sim 0$) and $R = 20 \text{ nm}$, then $\lambda = 8.5 \times 10^{-4} \text{ ns}^{-1}$, or $\tau = 1.2 \text{ }\mu\text{s}$. Proprietary experiments at Positronics Research LLC show that Ps atoms in crossed magnetic and electric fields in silica aerogel with 20-nm voids live up to $10 \text{ }\mu\text{s}$. This is somewhat longer than the predicted lifetime owing to severe radiation damage induced in the silica aerogel by positrons that alters k' from the values quoted above.

Measured lifetimes in the present experiments at Positronics Research LLC are within limits set by diffusion to the trap walls. This is consistent with the expectation that Ps atoms "stabilized" in crossed magnetic and electric fields will be "delocalized" and drift freely across magnetic field lines.

Future experiments at Positronics Research LLC will use super-dilute media ($R = 1,000 \text{ nm}$), large container volumes (10 cm), weak magnetic fields (< 0.1 Tesla), and electric fields. Substitution of $R = 1,000 \text{ nm}$ into Equation 2, assuming again a high vacuum and crossed magnetic and electric field suppression of self-annihilation, predicts a lifetime of 61 milliseconds. Assuming the following results are consistent with this prediction, it will be demonstrated beyond any reasonable doubt that Ps can be stabilized against "self-annihilation" in crossed fields.

To ultimately reach lifetimes of months and years required by aerospace propulsion, oscillating electric-gradient-field-confinement forces will be required to keep Ps atoms off the walls of a high-vacuum trap. Ps atoms will be produced by a beam of low-energy positrons intercepting silica aerogel and be stabilized in the trap using crossed magnetic and electric fields. Ps in crossed magnetic and electric fields has an enormous electric dipole moment, and confinement using the classical $\mathbf{p}\cdot\nabla\mathbf{E}$ force looks very encouraging at this time.

Conclusions

Conceptual designs and missions for turbojets, turbo-ramjet missiles, and interplanetary rockets powered by positron annihilation have been presented. Positron requirements range from 150 micrograms for a globe-encircling UAV turbojet flight to 100 milligrams for a mission to Mars. A positron-powered SSRV could take off from Earth horizontally, go to LEO, launch to Mars for a 1-year exploration of the Red Planet, and return to LEO and then Earth with a horizontal landing without refueling.

Within 10 years, the 150 μg of positrons required for a globe-encircling, nonstop turbojet flight could be made in 6 months at a cost of \$69 million. This first-ever antimatter voyage, approximately 90 years after Lindbergh's 1927 Spirit of St. Louis transatlantic flight, would stir the public's imagination and eventually lead to positron-powered exploration of the solar system in the 21st century.

New developments in stabilizing and storing positronium atoms in a matrix of dilute materials are encouraging. Lifetimes of 10 μ s have been achieved, and tens-of-millisecond lifetimes are expected in the next round of experiments. Present limits are due to interactions on the walls of the trap container. Application of oscillating gradient electric fields to the huge electric dipole moment of the stable Ps atom should mitigate this problem. With the issue of stabilization in crossed fields now settled, very long lifetimes are but a matter of engineering!

-
- ¹ P. A. M. Dirac, Proc. Roy. Soc. A .126, 360 (1930).
 - ² C. D. Anderson, Phys. Rev. 43, 491 (1933).
 - ³ O. Chamberlain, E. Segre, C. Wiegand and T. Ypsilantis, Phys. Rev. 100, 947 (1955).
 - ⁴ G. Luders, Ann. Phys. 2, 1-15 (1957).
 - ⁵ P. Hill and C. Peterson, Mechanics of Thermodynamics of Propulsion, 2nd ed., Addison - Wesley Publishing Co. (1992).
 - ⁶ G. Herken, "The Flying Crowbar", Air and Space Magazine, Vol. 5 (#1), p. 28, April/May (1990) (<http://www.merkle.com/pluto/pluto.html>).
 - ⁷ R. W. Bussard and R. D. DeLauer, Fundamentals of Nuclear Flight, McGraw-Hill Book Co. (1965)
 - ⁸ G. A. Smith et al., "Revolutionary Positron Conversion", Final Technical Report, AFRL Contract F08630-00-C-0010, Eglin AFB, FL, March (2002).
 - ⁹ O. Chamberlain, E. Segre, C. Wiegand and T. Ypsilantis, Phys. Rev. 100, 947 (1955)
 - ¹⁰ G. Luders, Ann. Phys. 2, 1-15 (1957).
 - ¹¹ G. A. Smith et al., "Revolutionary Positron Conversion", Final Technical Report, AFRL Contract F08630-00-C-0010, Eglin AFB, FL, March (2002).
 - ¹² Ibid.
 - ¹³ Ibid.
 - ¹⁴ Ibid.
 - ¹⁵ Ibid.
 - ¹⁶ Ibid.
 - ¹⁷ Ibid.
 - ¹⁸ Ibid.
 - ¹⁹ Northrop-Grumman Corp: Report to Kaiser-Marquardt for HTHL blended-body SSTO engine, "Vision Vehicle Final Report," April 30 (1998).
 - ²⁰ G. A. Smith et al., "A Revolutionary Positron Based SSRV Vehicle for Application to Human Exploration and Development of Space", The Advanced Space Propulsion Workshop, NASA Marshall Space Flight Center, Huntsville, AL, April 2-6 (2001).
 - ²¹ Northrop-Grumman Corp: Report to Kaiser-Marquardt for HTHL blended-body SSTO engine, "Vision Vehicle Final Report," April 30 (1998).
 - ²² G. A. Smith et al., "A Revolutionary Positron Based SSRV Vehicle for Application to Human Exploration and Development of Space", The Advanced Space Propulsion Workshop, NASA Marshall Space Flight Center, Huntsville, AL, April 2-6 (2001).
 - ²³ Ibid.
 - ²⁴ Ibid.
 - ²⁵ Ibid.
 - ²⁶ Ibid.
 - ²⁷ G. A. Smith, "Positron Propelled and Powered Space Transport Vehicle for Planetary Missions", NIAC Phase I Final Report, Research Subaward No. 07605-003-048, September 1, 2005 - March 31, 2006.
 - ²⁸ Ibid.
 - ²⁹ D. R. Koenig, "Experience Gained from the Space Nuclear Rocket Program (Rover)," LA-10062-H, Los Alamos National Laboratory, Los Alamos, NM., May (1986).
 - ³⁰ G. A. Smith, "Positron Propelled and Powered Space Transport Vehicle for Planetary Missions", NIAC Phase I Final Report, Research Subaward No. 07605-003-048, September 1, 2005 - March 31, 2006.
 - ³¹ L. E. Thode et al., J. Propulsion and Power 14, 4 (1998).
 - ³² D. I. Poston and T. Kammash, Nuclear Science and Engineering 122, 32 (1996).

- ³³ S. K. Borowski et al., "Nuclear Thermal Rocket/Vehicle Design Options for Future NASA Missions to the Moon and Mars," AIAA-93-4170 (NASA Tech Memorandum 107071), (1993).
- ³⁴ D. I. Poston and T. Kammash, *Nuclear Science and Engineering* 122, 32 (1996).
- ³⁵ S. K. Borowski et al., "Nuclear Thermal Rocket/Vehicle Design Options for Future NASA Missions to the Moon and Mars," AIAA-93-4170 (NASA Tech Memorandum 107071), (1993).
- ³⁶ G. A. Smith, "Positron Propelled and Powered Space Transport Vehicle for Planetary Missions", NIAC Phase I Final Report, Research Subaward No. 07605-003-048, September 1, 2005 – March 31, 2006.
- ³⁷ E. Sanger, *Ing. Arch.* 21, 213 (1953).
- ³⁸ G. A. Smith, "Positron Propelled and Powered Space Transport Vehicle for Planetary Missions", NIAC Phase I Final Report, Research Subaward No. 07605-003-048, September 1, 2005 – March 31, 2006.
- ³⁹ Ibid.
- ⁴⁰ G. Gaidos et al., "Antiproton-Catalyzed Microfission/fusion Propulsion Systems for Exploration of the Outer Solar System and Beyond," AIAA-98-3589, Presented at the 34th AIAA/ASME/SAE/ASEE Joint Propulsion Conference & Exhibit (1998).
- ⁴¹ W. Lance Werthman, "Antiproton-Catalyzed Microfission/fusion Space Propulsion," MS Thesis, Dept. of Aerospace Engineering, Penn State University (1995).
- ⁴² G. A. Smith, "High Density Storage of Antimatter", Advanced High Energy Storage Conference, MITRE Corp., McLean, VA, Aug. 1 (2005).
- ⁴³ S. J. Hoffman and D. I. Kaplan, eds. "Human Exploration of Mars: The Reference Mission of the NASA Mars Exploration Study Team," NASA Special Publication 6107, JSC (1997).
- ⁴⁴ B. G. Drake, ed. "Reference Mission Version 3.0: Addendum to the Human Exploration of Mars: The Reference Mission of the NASA Mars Exploration Study Team," <http://ares.jsc.nasa.gov/HumanExplore/Exploration/EXLibrary/docs/MarsRef/addendum/index.htm>, June (1998).
- ⁴⁵ G. A. Smith, "High Density Storage of Antimatter", Advanced High Energy Storage Conference, MITRE Corp., McLean, VA, Aug. 1 (2005).
- ⁴⁶ J. Dion, "Stirling Radioisotope Generator", NASA Glenn Research Center, ME 388R.2, Spring (2005).
- ⁴⁷ Ibid.
- ⁴⁸ G. A. Smith, "High Density Storage of Antimatter", Advanced High Energy Storage Conference, MITRE Corp., McLean, VA, Aug. 1 (2005).
- ⁴⁹ S. J. Hoffman and D. I. Kaplan, eds. "Human Exploration of Mars: The Reference Mission of the NASA Mars Exploration Study Team," NASA Special Publication 6107, JSC (1997).
- ⁵⁰ B. G. Drake, ed. "Reference Mission Version 3.0: Addendum to the Human Exploration of Mars: The Reference Mission of the NASA Mars Exploration Study Team," <http://ares.jsc.nasa.gov/HumanExplore/Exploration/EXLibrary/docs/MarsRef/addendum/index.htm>, June (1998).
- ⁵¹ S. K. Borowski et al., "Nuclear Thermal Rocket/Vehicle Design Options for Future NASA Missions to the Moon and Mars," AIAA-93-4170 (NASA Tech Memorandum 107071), (1993).
- ⁵² G. A. Smith, "Positron Propelled and Powered Space Transport Vehicle for Planetary Missions", NIAC Phase I Final Report, Research Subaward No. 07605-003-048, September 1, 2005 – March 31, 2006.
- ⁵³ S. J. Hoffman and D. I. Kaplan, eds. "Human Exploration of Mars: The Reference Mission of the NASA Mars Exploration Study Team," NASA Special Publication 6107, JSC (1997).
- ⁵⁴ B. G. Drake, ed. "Reference Mission Version 3.0: Addendum to the Human Exploration of Mars: The Reference Mission of the NASA Mars Exploration Study Team," <http://ares.jsc.nasa.gov/HumanExplore/Exploration/EXLibrary/docs/MarsRef/addendum/index.htm>, June (1998).
- ⁵⁵ G. A. Smith, "Positron Propelled and Powered Space Transport Vehicle for Planetary Missions", NIAC Phase I Final Report, Research Subaward No. 07605-003-048, September 1, 2005 – March 31, 2006.
- ⁵⁶ C.A. Kapatanakos, *J. Synchrotron Rad.* 3, 268-271 (1996).
- ⁵⁷ ILC undulator-based source, www.ippp.dur.ac.uk/~gudrid/source/BCD-source. ILC capitalization is estimated at \$9B (see www.linearcollider.org).
- ⁵⁸ Ibid.
- ⁵⁹ Ibid.
- ⁶⁰ R. Landua, CERN, "Precision Experiments with Antiprotons", Feb. 24 (2003).
- ⁶¹ S. Howe et al., *AIP Conf. Proc.* 746, 520 (2005).
- ⁶² 14 MeV Electron Linac @ \$5M capitalization cost and \$5M/yr operating cost (A. Herer et al., "Applications of High Voltage High Powered Electron Beams", IBA, Belgium, 1997).
- ⁶³ G. R. Schmidt et al., *J. Propulsion and Power*, 16, 923 (2000).
- ⁶⁴ J. Rejcek et al., *Rad. Phys. Chem.* 68, 655 (2003).
- ⁶⁵ G. A. Smith, "High Density Storage of Antimatter", Advanced High Energy Storage Conference, MITRE Corp., McLean, VA, Aug. 1 (2005).
- ⁶⁶ C. M. Surko and R. G. Greaves, *Phys. Plasmas* 11, 2333 (2004).

⁶⁷ G. A. Smith, "Long-Term Confinement of Dense Positron Plasmas", Final Technical Report, AFRL Contract F08630-02-C-0017, Eglin AFB, FL, January 23 (2007).

⁶⁸ Ibid.

⁶⁹ G. A. Smith, "Positron Energy Conversion (PEC)", 53th JANNAF Propulsion Meeting, Subcommittee on Future Technologies for Spacecraft Propulsion (2005 0356 EA), CPIAC JSC CD43 December (2005).

⁷⁰ G. A. Smith, "Stabilization and Long Term Confinement of Atomic Positronium", Final Technical Report, AFRL Contract F08630-02-C-0018, Eglin AFB, FL, January 23 (2007).

⁷¹ S. J. Hoffman and D. I. Kaplan, eds. "Human Exploration of Mars: The Reference Mission of the NASA Mars Exploration Study Team," NASA Special Publication 6107, JSC (1997).

⁷² G. A. Smith, "Stabilization and Long Term Confinement of Atomic Positronium", Final Technical Report, AFRL Contract F08630-02-C-0018, Eglin AFB, FL, January 23 (2007).

⁷³ J. Lu, "Classical Trajectory Monte Carlo Simulation of Ion-Rydberg Atom Collisions", Ph. D. Dissertation, University of Bielefeld, Germany, May (2003).

⁷⁴ Ibid.

⁷⁵ K. Sudarshan et al., J. Phys: Condens. Matter 19, 386 (2007).

⁷⁶ G. A. Smith, "Stabilization and Long Term Confinement of Atomic Positronium", Final Technical Report, AFRL Contract F08630-02-C-0018, Eglin AFB, FL, January 23 (2007).