

Manager CNR

From: office@ampsynergy.com
Sent: Friday, March 27, 2020 3:43 PM
To: manager@romarm.ro
Subject: Fwd: Urgent! Ofertă linie de producție măști CHINA
Attachments: 锐天口罩机1出2 (技术规格书)-1.pdf.pdf

Bună ziua,

În completarea adresei electronice transmisă către dumneavoastră în data de 25.03.2020, vă comunicăm detaliile privind termenii de livrare și de plată pentru utilajul companiei RAETTS, ofertă obținută prin intermediul CMEC China, pentru o linie completă de producție de măști de protecție.

Linia completă are o capacitate de producție de 90-120 de măști/ minut, iar mașina de ambalat integrată are o capacitate de ambalare de 10-50 de bucăți/pungă. Prețul ansamblului este de 142.860 de dolari. Nu sunt incluse aparatele de aer comprimat.

☺
Pentru o mașină de ambalat individual se mai adaugă 12.000 de dolari.

Termene și condiții de livrare:

- FOB China;
- modalitatea de plată: 30% avans, 70% la încărcarea produselor în containere;
- termen de livrare: 30 de zile de la primirea avansului.

Menționăm faptul că, din motive de solidaritate, compania noastră nu percepe adaosuri comerciale pentru această comandă, în cazul în care aceasta se va concretiza.

Vă rugăm să derulați demersurile necesare și să stabiliți oportunitatea lansării unei comenzi ferme în cel mai scurt timp.

Vă mulțumim,

Director AMP SYNERGY BUCUREȘTI

☺
MARIA MARIA POPOVICI
+40 732 680 722

----- Original Message -----

Subject: Urgent! Ofertă linie de producție măști CHINA
Date: 2020-03-25 09:31
From: office@ampsynergy.com
To: manager@romarm.ro

Bună ziua!

Atașat regăsiți oferta din partea CMEC pentru linie completă de producție de măști de protecție. Conform discuției cu reprezentantul CMEC, producătorul așteaptă o comandă fermă în maxim 48 de ore, ca urmare a faptului că există multiple solicitări pentru acest tip de utilaj!

Menționăm că atât CMEC, cât și compania noastră, nu percep adaosuri comerciale pentru această comandă.

Vă rugăm să derulați demersurile necesare și să stabiliți oportunitatea lansării unei comenzi ferme în cel mai scurt timp.

- Vă mulțumim,

Director AMP SYNERGY București,
ANA MARIA POPOVICI

RAETTS

东莞市锐天机电科技有限公司

Dongguan RuiTian Electrical Technology Co., LTD

电话(Tel): 0769-81190028 传真(Fax): 0769-81190038

地址 Add: 东莞市寮步镇聚园二路 20 号 雷茨高新科技园

RAETTS Hi-tech Park, No. 20 Juyuan Second Road, Shangtun Village, Liaobu Town, Dongguan City

高速平面耳带式口罩全自动机 (High-speed flat earloop fully automatic mask machine) (一拖二)

技术规格书 (Technical Specification)

型号(Model) : RT 120-2 8.8

本协议书的內容未经书面形式的许可，不得将本协议书向买卖双方以外的人或机构公开
(The contents of this agreement shall not be disclosed to persons or institutions other than the seller and the buver without written permission)

(此份仅为推荐版，以签字生效为准 This is a recommended version only)

甲 方 (Party A):

乙 方 (Party B):

代 表 (Representative):

代 表 (Representative):

签约日期 (Date):

签约日期 (Date):

RAETTS

东莞市锐天机电科技有限公司

Dongguan RuiTian Electrical Technology Co., LTD

电话(Tel): 0769-81190028 传真(Fax): 0769-81190038

地址 Add: 东莞市寮步镇聚园二路20号 雷茨高新科技园

RAETTS Hi-tech Park, No. 20 Juyuan Second Road, Shangtun Village, Liaobu Town, Dongguan City

1、机器外形参考图 Machine outline reference drawing (最终以实物为准 The actual product shall prevail)

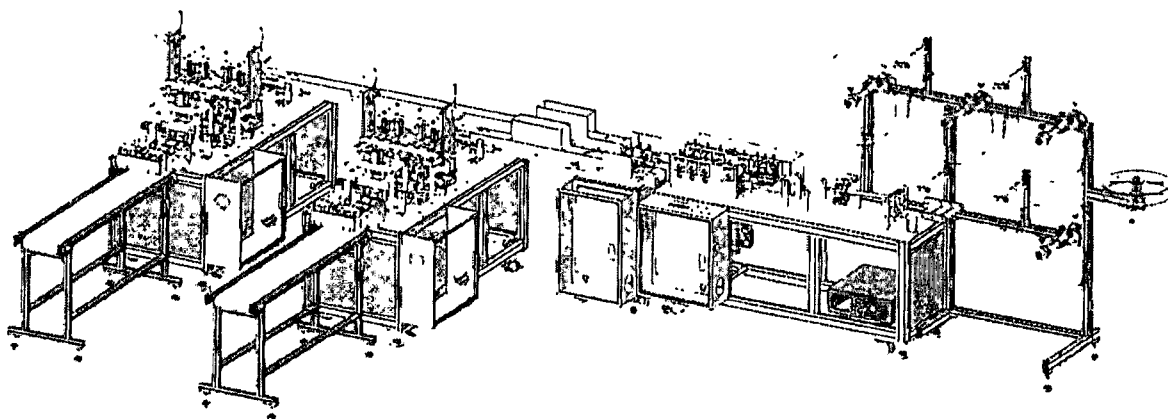

2、适用范围 Range of application

本机适用于自动生产多层材质平面口罩成品，可使用1-1层PP纺粘无纺布、活性炭以及过滤材料，整机从原材料入料到鼻线插入、封边和裁切成品均为一条线自动化作业，根据所使用的原材料不同，可以达到一次性平面口罩等不同的标准。

该平面口罩生产设备性能稳定，产量高，不良率低，易于操作。

This machine is suitable for the automatic production of multi-layer flat mask products. It can use 1 to 1 layers of PP spunbond non woven fabrics, activated carbon and filter materials. The whole machine is a line of automated operation from raw material feeding to nose line insertion, edge sealing and cutting finished products.

Depending on the raw materials used, different standards such as disposable flat masks can be achieved.

The flat mask production equipment has stable performance, high output, low defect rate and easy operation.

3、机器特点及性能 Machine characteristics and performance

1. 全自动送料系统 Automatic feeding system;
2. 铝合金机架，坚固美观，保证成品的尺寸精确 Strong and beautiful aluminum frame to ensure the precise dimensions of the finished product;
3. 不锈钢夹具，可左右调节 Stainless steel clamp, adjustable left and right;
4. 张紧轮设置，调节布幅张紧度，从而有效保证成品的美观和平整度 Tensioning wheel setting, which can adjust the tension of the fabric, so as to effectively ensure the beauty and flatness of the finished product;
5. 独立鼻线输送组，方便调整以及维护 Independent nose line conveyor set for easy adjustment and maintenance;
6. 超声波自动热合，确保焊接品质稳定 Ultrasonic automatic heat sealing to ensure stable welding quality;
7. 自动成型出料，适应快速生产 Automatic forming and discharging, suitable for rapid production.

4、主要技术参数 Main technical parameters

序号 Item	主要项目内容 Main project content	主要技术参数 Main technical parameters
1	工作电源 Working power supply	220V, AC $\pm 5\%$, 50HZ
2	设备功率 Equipment power	约 8.8KW (About 8.8KW)

RAETTS

东莞市锐天机电科技有限公司

Dongguan RuiTian Electrical Technology Co., LTD

电话(Tel): 0769-81190028 传真(Fax): 0769-81190038

地址 Add: 东莞市寮步镇聚园二路 20 号 雷茨高新科技园

RAETTS Hi tech Park, No. 20 Juyuan Second Road, Shangtun Village, Liaobu Town, Dongguan City

3	压缩空气 Compressed air	0.5~0.8MPa, 经初级干燥、过滤 (0.5 ~ 0.8MPa, after primary drying and filtering) 使用流量: 约 305L/Min (Airflow used: about 305L / Min)
4	使用环境 Use environment	工作温度: 0~40° C (working temperature: 0~40° C)
		湿度: 5~38%HR (Humidity: 5~38%HR)
		无可燃性气体、腐蚀性气体 No combustibile gas or corrosive gas 车间无尘 (不低于 10 万级) Dust free workshop (no less than Grade 100000)
5	操作高度 Operation height	约 900mm (About 900mm)
6	生产效率 Production efficiency	90~120 件/分钟 (一出二) 90-120 pieces / minute (Two at a time)
7	设备主要外形尺寸 Main dimensions of equipment	约 6800mm*4800mm*1860mm

5、主要元器件配置参考 Configuration reference of main components:

序号 Item	项目名称 Component	品牌 Brand	备注 Remark
1	气动组件 Pneumatic component	国优或 AIRTAC (Domestic high quality products or AIRTAC)	
2	伺服系统 Servo system	信捷 (XINJE)	

RAETTS

东莞市锐天机电科技有限公司

Dongguan RuiTian Electrical Technology Co., LTD

电话(Tel): 0769-81190028 传真(Fax): 0769-81190038

地址 Add: 东莞市寮步镇聚园二路 20 号 雷茨高新科技园

RAETTS Hi Tech Park, No. 20 Juyuan Second Road, Shangtun Village, Liaobu Town, Dongguan City

4	人机界面 HMI	信捷(XINJE)	
5	电机 Motor	国优(Domestic high quality products)	
6	传感器 Sensor	欧姆龙或松下 (OMRON/Panasonic)	
7	变频器 Inverter	英威腾、国优产品 (INVT/Domestic high quality products)	
8	超声波组件 Ultrasonic components	20KHZ 或 15KHZ (20KHZ or 15KHZ)	
9	成型模具 Forming die	Prevail	根据客户产品型号 (Based on customer product model)
10	低压电器、指示灯等 Low voltage appliances, indicator lights, etc	施耐德、欧姆龙 (Schneider/OMRON)	

6、质量保证 Quality assurance

1. 乙方提供的系统及其所配备的各种配件、附件和备件, 是以完善的工艺和优质材料制成的, 是全新未被使用过, 在各方面都符合本技术需求所规定的质量和规格要求。The system provided by Party B and all kinds of accessories, attachments and spare parts are made of perfect technology and high-quality materials, which are brand new and unused, and meet the quality and specification requirements specified in the technical requirements in all aspects.

RAETTS

东莞市锐天机电科技有限公司

Dongguan RuiTian Electrical Technology Co., LTD

电话(Tel): 0769-81190028 传真(Fax): 0769-81190038

地址 Add: 东莞市寮步镇聚园二路 20 号 雷茨高新科技园

RAETTS Hi Tech Park, No. 20 Juyuan Second Road, Shangtun Village, Liaohu Town, Dongguan City

2. 设备及其部件具有可靠的稳定性, 且刚性、抗震性、运动耐磨性好, 工作性能稳定。The equipment and its components have reliable stability, rigidity, earthquake resistance, good wear resistance and stable working performance.

3. 设计、制造和装配均符合国家标准。The design, manufacture and assembly are in accordance with national standards.

7、售后服务 After-sales service

1. 质保期 Warranty period

设备验收合格后保修一年, 保修期从验收合格之日起算。保修期内的服务由乙方免费提供(人为因素及易损件除外)。The equipment shall be guaranteed for one year after acceptance, and the warranty period shall be calculated from the date of acceptance. During the warranty period, Party B shall provide services free of charge (excluding human factors and vulnerable parts).

2. 维修响应时间 Maintenance response time

在甲方遇到故障时, 可以随时向乙方公司技术人员进行咨询, 在技术人员的指导下进行操作; 如果甲方遇到自己不能解决的故障, 需要进行现场服务的, 乙方承诺 1 小时内响应, 4 小时内给出解决方案, 48 小时内上门服务。In case of any fault, Party A may consult with the technical personnel of Party B at any time and operate under the guidance of the technical personnel; if Party A encounters any fault that cannot be solved by itself and needs on-site service, Party B shall promise to respond within 1 hour, provide a solution within 4 hours and provide on-site service within 48 hours.

RAETTS

东莞市锐天机电科技有限公司

Dongguan RuiTian Electrical Technology Co., LTD

电话(Tel): 0769-81190028 传真(Fax): 0769 81190038

地址 Add: 东莞市寮步镇聚园二路 20 号 雷茨高新科技园

RAETTS Hi Tech. Park, No. 20 Juyuan Second Road, Shuangtun Village, Liaobu Town, Dongguan City

3. 保修期后服务保障 **Service guarantee after warranty period**

a) 乙方具有良好的产品质量信誉和完善的售后服务体系, 保修期过后, 乙方仍提供技术支持。

Party B has good product quality reputation and perfect after-sales service system.

After the warranty period, Party B still provides technical support.

b) 乙方积极配合设备维修工作, 收费优惠合理, 并及时提供所需配件或替代品。Party B shall actively cooperate with the equipment maintenance work, with reasonable charges and

timely provide the required accessories or substitutes.

OFERTA FINANCIARA**CATRE**

ROMARM, cu sediul social in Bd. Timisoara, nr. 5B, sector 6, 061301, Bucuresti

Director General: Gabriel TUTU

INTERARMS IMPEX SRL, in calitate de furnizor, ofera urmatoarele:

Nr. crt.	Produse	U.M.	Cantitate	Pret unitar (USD fara TVA)	Pret total (USD fara TVA)
1.	Masina de confectionat masti pentru fata, de mare viteza cu linii duble de productie Productie: 8000 bucati/ora	buc.	3	194.300 USD	582.900 USD
2.	Masina de confectionat masti pentru fata N95	buc.	1	396.966 USD	396.966 USD
				TOTAL (USD fara TVA)	979.866 USD

Observatii: Lista pieselor de schimb este inclusa in valoarea totala a produselor.**CONDITII:**

- **Pretul:** preturile mentionate nu contin TVA si sunt considerate CIP Otopeni.
- **Livrarea:** termenul de livrare este de maxim maximum 15 zile lucratoare de la intrarea in vigoare a contractului, la aeroportul din Otopeni.
- Transportul pana la locul de receptie a produselor va fi organizat de comun acord cu Achizitorul si este inclus in pretul total al contractului pana la valoare maxima de 170.800 USD, daca nu se va identifica o modalitate de transport pana la suma respectiva, Furnizorul are dreptul de a solicita plata diferentiei pana la acoperirea totala a tuturor costurilor si taxelor de transport.
- **Plata:** - Avans de 50% din suma care se va achita in maxim 2 zile de la data intrarii in vigoare a contractului;
- Avans de 20 % din suma se va achita dupa ce marfa si documentele vor fi verificate la fabrica producatorului, de catre un agent SGS.
- Soldul de 30 % din suma se va achita in 24h de la receptia produselor.

Cu stima,

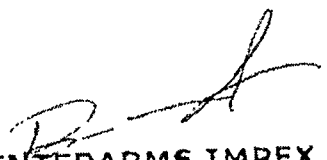
**INTERARMS IMPEX SRL
BARSANTI RICCARDO**
INTERARMS IMPEX S.R.L.
General Manager
Riccardo Barsanti

Bucuresti, 27 Martie 2020

INTERARMS IMPEX SRL

Sos. Pipera Nr.48 , Sect.2 Bucuresti, Romania

CUI R034620937 – J40/6884/2015

INTERARMS

OFERTA FINANCIARA

CATRE

ROMARM, cu sediul social in Bd. Timisoara, nr. 5B, sector 6, 061301, Bucuresti

Director General: Gabriel TUTU

INTERARMS IMPEX SRL, in calitate de furnizor, va oferta produsele din anexa

CONDITII:

- **Pretul:** preturile mentionate nu contin TVA si sunt considerate FOB Shenzhen
- **Livrarea:** termenul de livrare este de maxim 10 zile lucratoare de la plata avansului.
Conditiiile referitoare la livrare se vor stabili de comun acord, taxele de transport nu sunt incluse in oferta financiara.
- **Plata:** - Avans de 50% din suma care se va achita la data semnarii contractului:
 - 50% din suma ramasa se va achita pana la data livrarii.
 - Plata se va face in RON la cursul BNR din ziua emiterii facturii

MENTIONAM CA PREZENTA OFERTA ARE O VALABILITATE DE 24h DE LA DATA TRANSMITERII

Cu stima,

INTERARMS IMPEX SRL

BARSANTI RICCARDO

INTERARMS IMPEX S.R.L
General Manager
Riccardo Barsanti

Bucuresti, 27 Martie 2020

info@interarms.ro | Fax 031 101 9995 | Tel 031 101 9995

ANEXA 1 - OFERTA MATERIA PRIMA

3ply Disc							
Item	Specificati on	Usage(g /pcs)	PCS. Of Mask	Min.Total (T)	Unit USD/T	Total USD	NOTE V=M3
ear loop	D=2.8mm	0.29	15000000	5	20599	102995	45
nose clip	3.0*0.5mm, single	0.27	15000000	5	9170	45851	10
melt-blown non woven	25g/M2	0.52	5000000	3	71743	213728	30
TOTALURI			T	13	N/A	362574	85

N95 3ply mask							
Item	Specificati on	Usage(g /pcs)	PCS. Of Mask	Min.Total (T)	Unit USD/T	Total USD	NOTE V=M3
ear loop	5mm flat type	0.47	2000000	1	28759	28759	9
double core nose clip	PP+ iron wire 2pcs	0.555	2000000	2	9399	18798	3.6
melt-blown non woven	99# 25g/M2	1.755	500000	1	80247	80247	10
Static Filter cotton	50g/m2	1.755	2000000	4	19036	76145	80
TOTALURI			T	8	N/A	203949	107.6
TOTALURI 3PLY+N95				21		566523	188
COSTURI ESTIMATE DE TRANSPORT (3PLY+N95)						200000	

Arhizitor
C.N. ROMARM S.A. S C INTI RARMS

Furnizor
INTERARMS IMPEX SRI

General Manager
TUTU GABRIEL

General Manager
BARSANII RICCARDO

INTERARMS IMPEX SRI
C.N. ROMARM S.A. S C INTI RARMS
BARSANII RICCARDO